

TABLE OF CONTENTS

Section 100 – General Surface Improvements

DETAIL No.	DESCRIPTION	Revised Date
R-103	Typical Utility Main Locations	1/2013
R-104A	Sidewalk Detail	2/2026
R-104B	Notes – Sidewalk Detail	2/2026
R-104C	Decorative Colored P.C.C. Sidewalk	2/2026
R-104D	Decorative Colored P.C.C. Sidewalk Jointing Pattern	2/2026
R-104E	General Notes Decorative Colored Concrete Sidewalks/Driveways/Pedestrian Ramps	2/2026
R-104F	Test Section Decorative Colored Concrete Sidewalks/Driveways/Pedestrian Ramps	2/2026
R-104G	Integrally Decorative Colored Concrete Sidewalks/Driveways/Ped Ramps Cure and Seal	2/2026
R-104H	Expansion and Control Jointing Decorative Colored Concrete Sidewalks and Driveways	2/2026
R-105	Sidewalk Cross-Drain	2/2026
R-106A	Pedestrian Ramp – Existing Sidewalks	2/2026
R-106B	Pedestrian Ramp – Narrow Sidewalks	2/2026
R-106C	Pedestrian Ramp – Wide Sidewalks	2/2026
R-106D	Pedestrian Ramp Midblock-Type 1	2/2026
R-106E	Pedestrian Ramp Midblock-Type 2	2/2026
R-106F	Pedestrian Ramp – Details	2/2026
R-106G	Notes – Pedestrian Ramp	2/2026
R-107	P.C.C. Valley Gutter	1/2023
R-108	Longitudinal P.C.C. Valley Gutter	1/2023
R-109A	P.C.C. Type 1 Curb & Gutter	2/2026
R-109B	P.C.C. Type E Curb & Gutter	2/2026
R-109C	P.C.C. Type R Curb & Gutter	2/2026
R-110	P.C.C. Median Curbs	1/2023
R-111	P.C.C. Reinforced Retaining Curb	2/2026
R-112	Curb Opening	2/2026
R-113	Storm Drain Inlet Protection	1/2013
R-114A	P.C.C. Driveway Apron	2/2026
R-114B	P.C.C. Driveway Apron – Parkway	2/2026
R-114C	Notes – P.C.C. Driveway Apron	2/2026

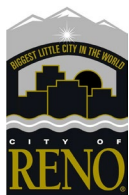

TABLE OF CONTENTS

R-114D	P.C.C. Driveway Apron – Rebar	2/2026
R-115A	Driveway Geometrics	11/2016
R-115B	Driveway Geometrics	1/2013
R-116A	P.C.C. Alley	2/2026
R-116B	Notes – P.C.C. Alley	2/2026
R-117	Sidewalk Plate for Tree Root Clearance	1/2013
R-119A	Concrete Pavement Patch	8/2014
R-119B	Details – Concrete Pavement Patch	2/2026
R-119C	Notes – Concrete Pavement Patch	2/2026
R-120	Permanent Bituminous Pavement Patch	1/2013
R-121	Temporary A.C. Trench Patch	1/2013
R-122	Trench Excavation/Backfill	3/2014
R-124	Monuments	1/2023

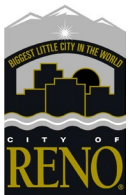

TABLE OF CONTENTS

Section 200 – Sewer /Storm Drain Improvements

DETAIL No.	DESCRIPTION	Revised Date
R-201	Lot Line Drainage Swale	1/2023
R-202	Major Drainage Channel	1/2013
R-203	Yard Drain	1/2023
R-204	Water/Sewer Separation	2/2026
R-205	Catch Basin Type 3-R	1/2023
R-206A	Catch Basin Type 4-R	1/2023
R-206B	Notes – Catch Basin Type 4-R	1/2023
R-207A	High Capacity Curb Inlet	12/2019
R-207B	Catch Basin Dual Type 4-R (Under Development)	12/2019
R-208A	Manhole Type I	1/2023
R-208B	Manhole Type V	1/2023
R-208C	Notes – Manhole Type I & Type V	1/2023
R-209	Manhole – Outside Drop	1/2013
R-210A	Manhole Type VI – Large Diameter Pipe	2/2026
R-210B	Notes – Manhole Type VI – Large Diameter Pipe	2/2026
R-213	Catch Basin Oil/Water Separator	1/2013
R-214A	24” Manhole Frame & Cover	4/2015
R-214B	36” Manhole Frame with 24” Cover Adaptor	3/2014
R-214C	Temporary Manhole Cover	1/2013
R-218A	Manhole Collar	1/2023
R-218B	Manhole Collar Easement Areas	1/2023
R-223A	Sanitary Sewer Pipe to Manhole Connection	4/2014
R-223B	Storm Drain Pipe to Manhole Connection	4/2014
R-223C	Resilient Flexible Connector	4/2014
R-224A	Sanitary Sewer Lateral	1/2013
R-224B	Notes – Sanitary Sewer Lateral	9/2022
R-224C	Sanitary Sewer Tap Saddle	1/2013
R-225	Culvert Headwall	1/2023
R-226	Headwall Trash Rack	1/2023
R-227	Storm Drain Access Roads (For Hillside Development)	1/2013

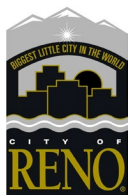

TABLE OF CONTENTS

Section 300 – Water Systems Improvements

DETAIL No.	DESCRIPTION	Revised Date
R-301A	Fire Hydrant	01/2020
R-301B	Notes – Fire Hydrant	01/2020
R-301C	Notes – Fire Hydrant	01/2020
R-301D	Notes – Fire Hydrant	01/2020
R-302	Fire Hydrant Marker Locations	01/2013

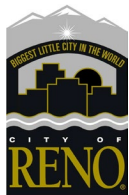

TABLE OF CONTENTS

Section 400 – Traffic Control Improvements

DETAIL No.	DESCRIPTION	Revised Date
R-401	Street Name Sign	2/2026
R-402A	Emergency Access Control Gate	2/2026
R-402B	Emergency Access Control Gate	2/2026
R-402C	Emergency Access Control Gate	2/2026
R-403A	Speed Bump Layout, Signage & Striping	2/2026
R-403B	Speed Bump Cross Sections	1/2023
R-403C	Notes & Speed Bump Joint Details	1/2023
R-404	Traffic & Lighting Conduit Trench	2/2026
R-406A	Loop Detector Layout	2/2026
R-406B	Loop Detector Layout	2/2026
R-406C	Notes – Loop Detector Layout	2/2026
R-407	Parking Space Markings	2/2026
R-412A	Standard Pull Box	2/2026
R-412B	Traffic Rated Pull Box	2/2026
R-413A	Traffic Signal Pole and Equipment	2/2026
R-413B	Traffic Signal Decorative Pole	2/2026
R-413C	Decorative Street Light Pole	2/2026
R-413D	Decorative Street Light Pole	2/2026
R-413E	Pole Street Name Sign	2/2026
R-413F	Notes – Traffic Signals & Poles	2/2026
R-413G	Notes – Traffic Signals & Poles	2/2026
R-413H	Notes – Traffic Signals & Poles	2/2026
R-413I	Notes – Traffic Signals & Poles	2/2026
R-413J	Light Pole Footing	2/2026
R-414	Traffic Parking Signs	2/2026
R-415A	Traffic Sign Installation	2/2026
R-415B	Notes – Traffic Sign Installation	2/2026
R-417A	School Zone Flashers – Overhead	2/2026
R-417B	Notes – School Zone Flashers – Overhead	2/2026
R-417C	School Zone Flashers – Roadside	2/2026
R-417D	Notes – School Zone Flashers – Roadside	2/2026
R-417E	Post Mounted Rectangular Rapid Flashing Beacon (RRFB)	2/2026
R-417F	Notes – Post Mounted Rectangular Rapid Flashing Beacon (RRFB)	2/2026

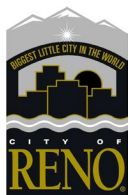

TABLE OF CONTENTS

R-417G	Overhead Rectangular Rapid Flashing Beacon (RRFB)	2/2026
R-417H	Notes – Overhead Rectangular Rapid Flashing Beacon (RRFB)	2/2026
R-417I	Notes – Overhead Rectangular Rapid Flashing Beacon (RRFB)	2/2026
R-418	Median Island Traffic Control	2/2026
R-420	Crosswalk Legend	2/2026
R-430	Typical Street Light Layout	2/2026

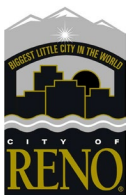

TABLE OF CONTENTS

Section 500 – Landscape Improvements

DETAIL No.	DESCRIPTION	Revised Date
R-500A	Notes – Urban Trees	12/2019
R-500B	Notes – Urban Trees	12/2019
R-500C	Notes – Urban Trees	12/2019
R-500D	Notes – Urban Trees Prohibited Species List	12/2019
R-500E	Urban Tree List	12/2019
R-500F	Urban Tree List	12/2019
R-500G	Urban Tree List	12/2019
R-500H	Urban Tree List	12/2019
R-500I	Urban Tree List	12/2019
R-500J	Urban Tree List	12/2019
R-500K	Soil Installation Specifications	12/2019
R-500L	Soil Composition Specifications	12/2019
R-501A	Tree Well With Curb	12/2019
R-501B	Tree Well With Grate	12/2019
R-501C	Tree With Parkway	12/2019
R-501D	Notes – Tree Wells	12/2019
R-520A	Tree Well Drip Irrigation	12/2019
R-520B	Parkway Drip Irrigation	12/2019

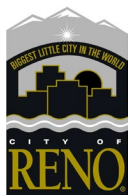
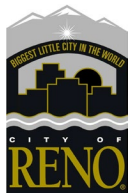
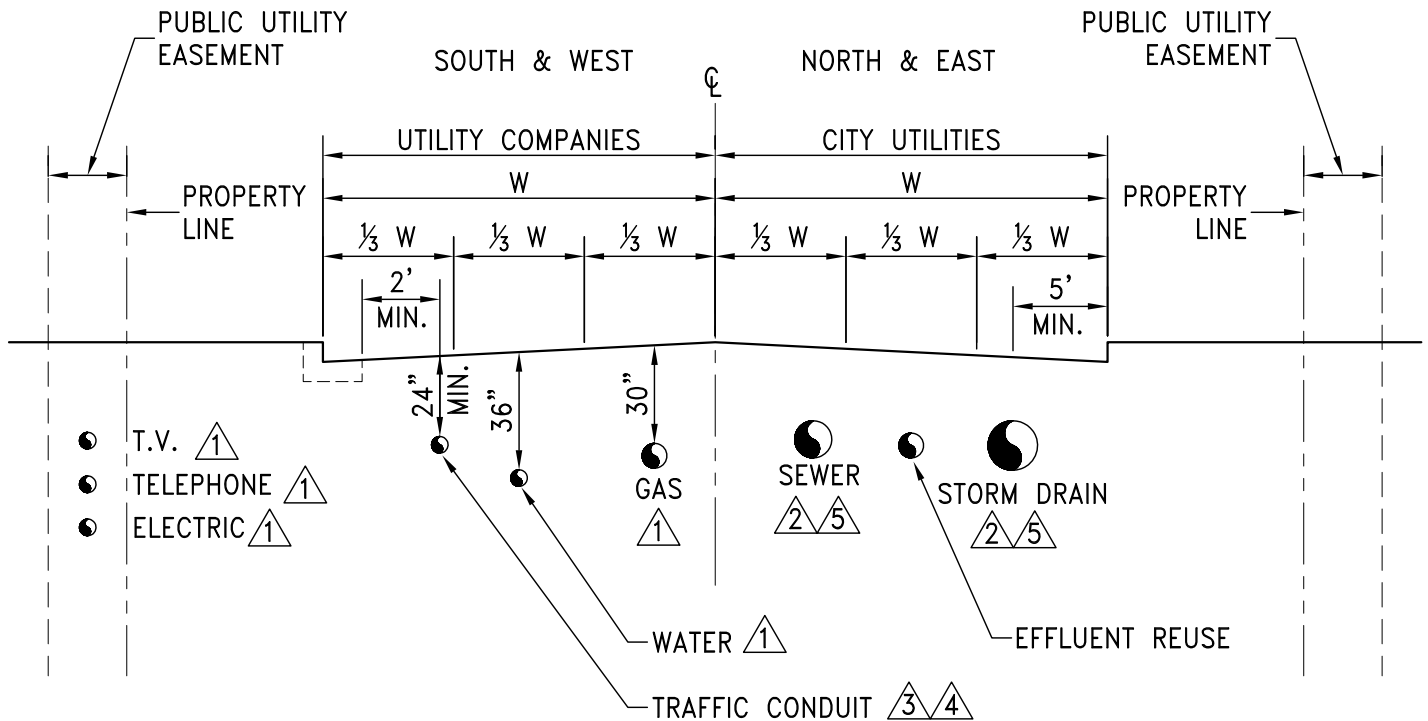

TABLE OF CONTENTS

Section 600 – Miscellaneous Details

DETAIL No.	DESCRIPTION	Revised Date
R-601	Sound Barrier	12/2019
R-602	Electronic Gate Access Box	12/2019
R-603A	Removable Bollard	2/2026
R-603B	Decorative Bollard	1/2023
R-604A	Masonry Retaining Walls I – L&S	12/2019
R-604B	Masonry Retaining Walls	12/2019
R-604C	Notes – Masonry Retaining Walls	12/2019
R-604D	Notes – Masonry Retaining Walls	12/2019
R-605	Bike Rack	12/2019
R-606	Pedestrian Safety Railing	2/2026





ABBREVIATIONS:

W = WIDTH FROM CENTERLINE (CL) OF ROADWAY TO FRONT FACE OF CURB.

NOTES:

- 1. SEE OWNING UTILITY COMPANY FOR STANDARD TRENCH SECTIONS.
- 2. SEE STANDARD DETAIL R-122 FOR TYPICAL SANITARY SEWER AND STORM DRAIN TRENCH SECTION.
- 3. SEE STANDARD DETAIL R-404 AND R-405 FOR TYPICAL TRAFFIC CONDUIT TRENCH SECTION.
- 4. TRAFFIC CONDUITS ARE ALLOWED TO BE PLACED ON EITHER SIDE OF THE ROADWAY PER THE DIMENSION LIMITATIONS SHOWN.
- 5. MINIMUM DISTANCE FROM CENTERLINES OF EITHER STORM DRAIN OR SEWER LINES TO THE FACE OF CURB IS 5 FEET.

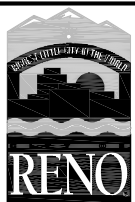

STANDARD DETAILS FOR PUBLIC WORKS CONSTRUCTION

DRAWING No.

**TYPICAL UTILITY
MAIN LOCATIONS**

R-103

APPROVED BY: JF DATE: 1/2013

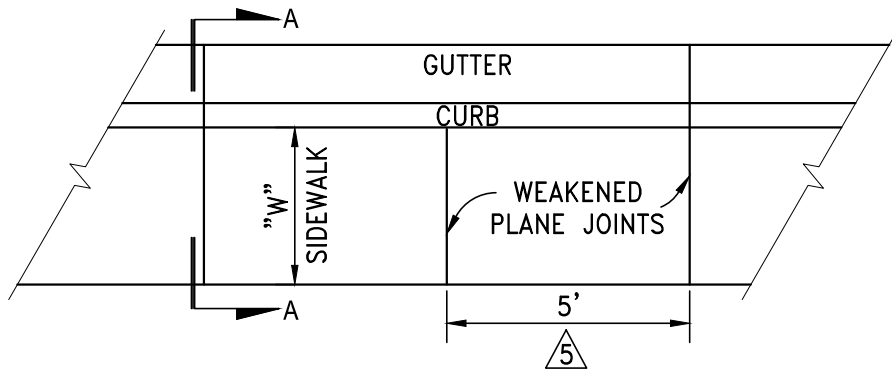

TYPE A SIDEWALK

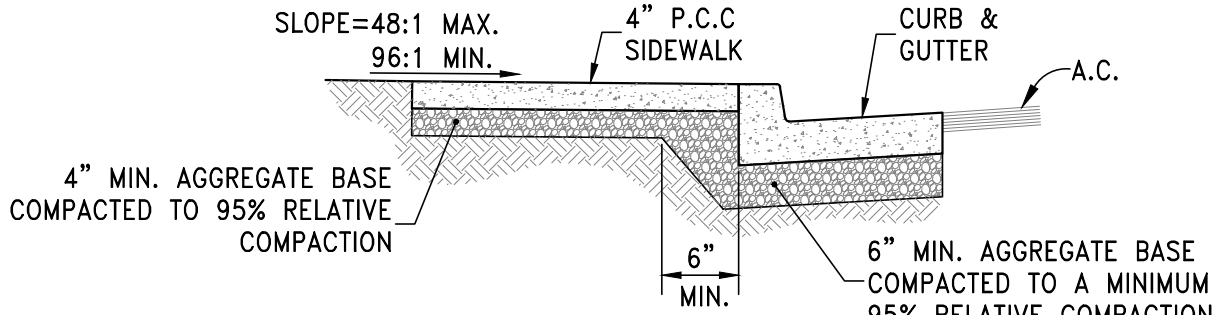

SECTION A-A

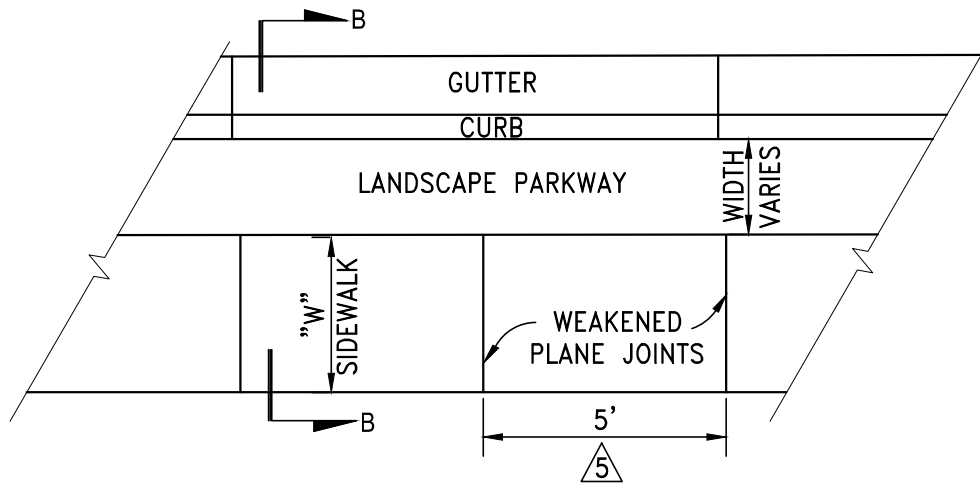

TYPE B SIDEWALK

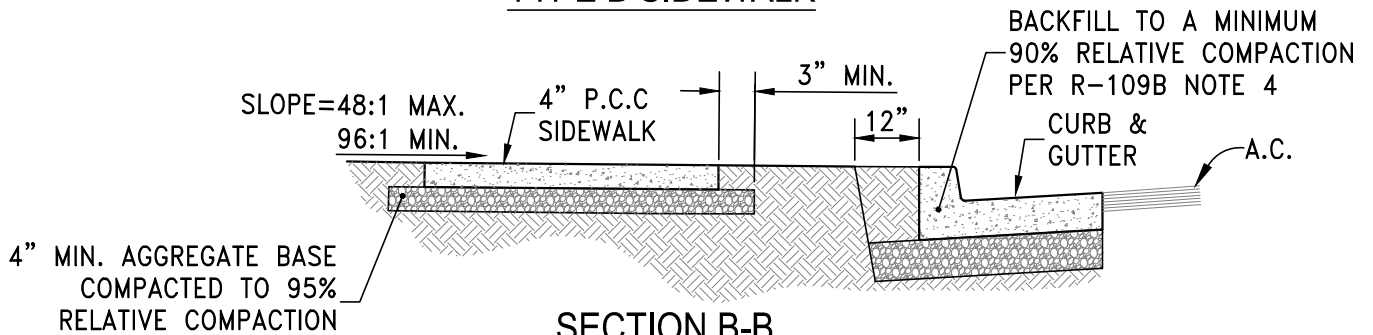

SECTION B-B



STANDARD DETAILS FOR PUBLIC WORKS CONSTRUCTION

DRAWING No.

SIDEWALK DETAIL

R-104A

APPROVED BY: KK DATE: 2/2026

NOTES:

1. PORTLAND CEMENT CONCRETE (P.C.C.) SHALL BE 4000 PSI MIN. COMPRESSIVE STRENGTH AT 28 DAYS. ALL CEMENT CONCRETE SHALL HAVE A COARSE AGGREGATE GRADATION CONFORMING TO SIZE No. 67. POLYPROPYLENE OR CELLULOSE FIBERS SHALL BE ADDED TO THE P.C.C. AT 1.5 LBS PER CUBIC YARD. MIX DESIGN SHALL CONFORM TO THE REQUIREMENTS OF SECTION 337.10 OF SSPWC. ALL MATERIALS SHALL CONFORM TO SSPWC.
2. AGGREGATE BASE MATERIAL UNDER SIDEWALKS SHALL BE TYPE 2, CLASS B CRUSHED AGGREGATE BASE. MATERIALS SHALL CONFORM TO SSPWC SECTION 200.
3. SIDEWALK WIDTH "W" SHALL BE PER PLAN.
4. WEAKENED PLANE JOINTS TYPICALLY SHALL BE CONSTRUCTED AT 5 FT INTERVALS OR ACCORDANCE WITH SECTION 312 OF THE SSPWC.
5. ALL ADJACENT CONCRETE REMOVAL SHALL BE TO NEAT SAW CUT LINES AT RIGHT ANGLES TO NEW SIDEWALK AT NEAREST WEAKENED PLANE JOINT. NO OVERCUTS. DOWEL INTO EXISTING ADJACENT CONCRETE SIDEWALK WITH A MINIMUM OF TWO (2) No. 4 REINFORCEMENT BARS 10" IN LENGTH. DOWELS SHALL BE EQUALLY SPACED ACROSS WIDTH "W" AND DOWELS SHALL PENETRATE A MINIMUM OF 4" INTO EXISTING CONCRETE.
6. SIDEWALKS SHALL NOT BE POURED MONOLITHICALLY WITH CURBS.
7. COLORED CONCRETE AND PAVERS ARE NOT ALLOWED.
8. TUNNELING AND/OR BORING IS NOT ALLOWED.



STANDARD DETAILS FOR PUBLIC WORKS CONSTRUCTION

DRAWING No.

NOTES - SIDEWALK DETAIL

R-104B

APPROVED BY: KK | DATE: 2/2026

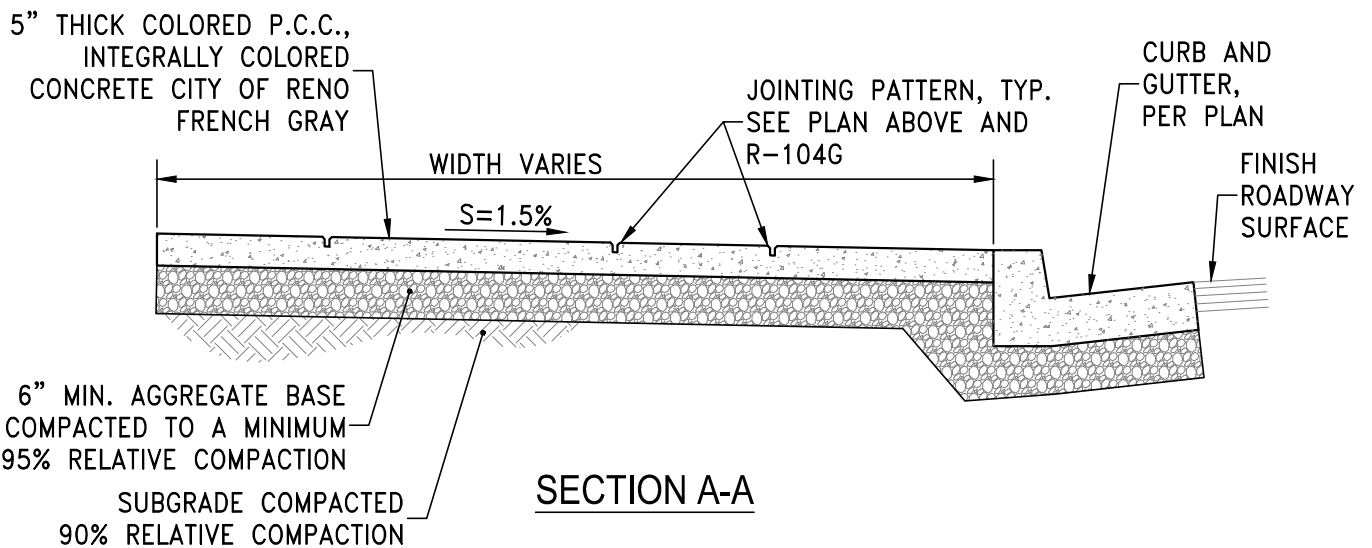
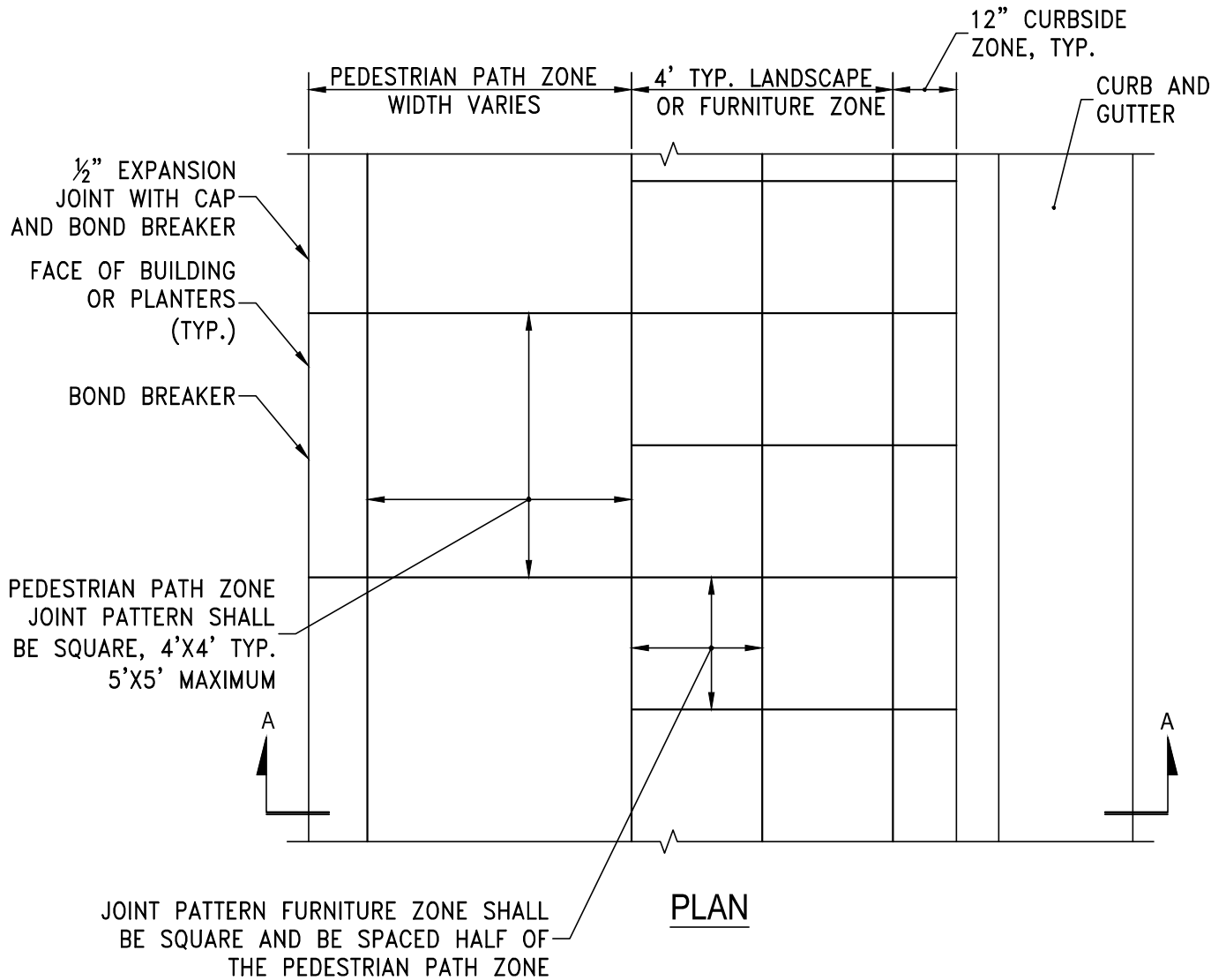

STANDARD DETAILS FOR PUBLIC WORKS CONSTRUCTION

DRAWING No.

**DECORATIVE COLORED
P.C.C. SIDEWALK**

R-104C

APPROVED BY: KK DATE: 2/2026

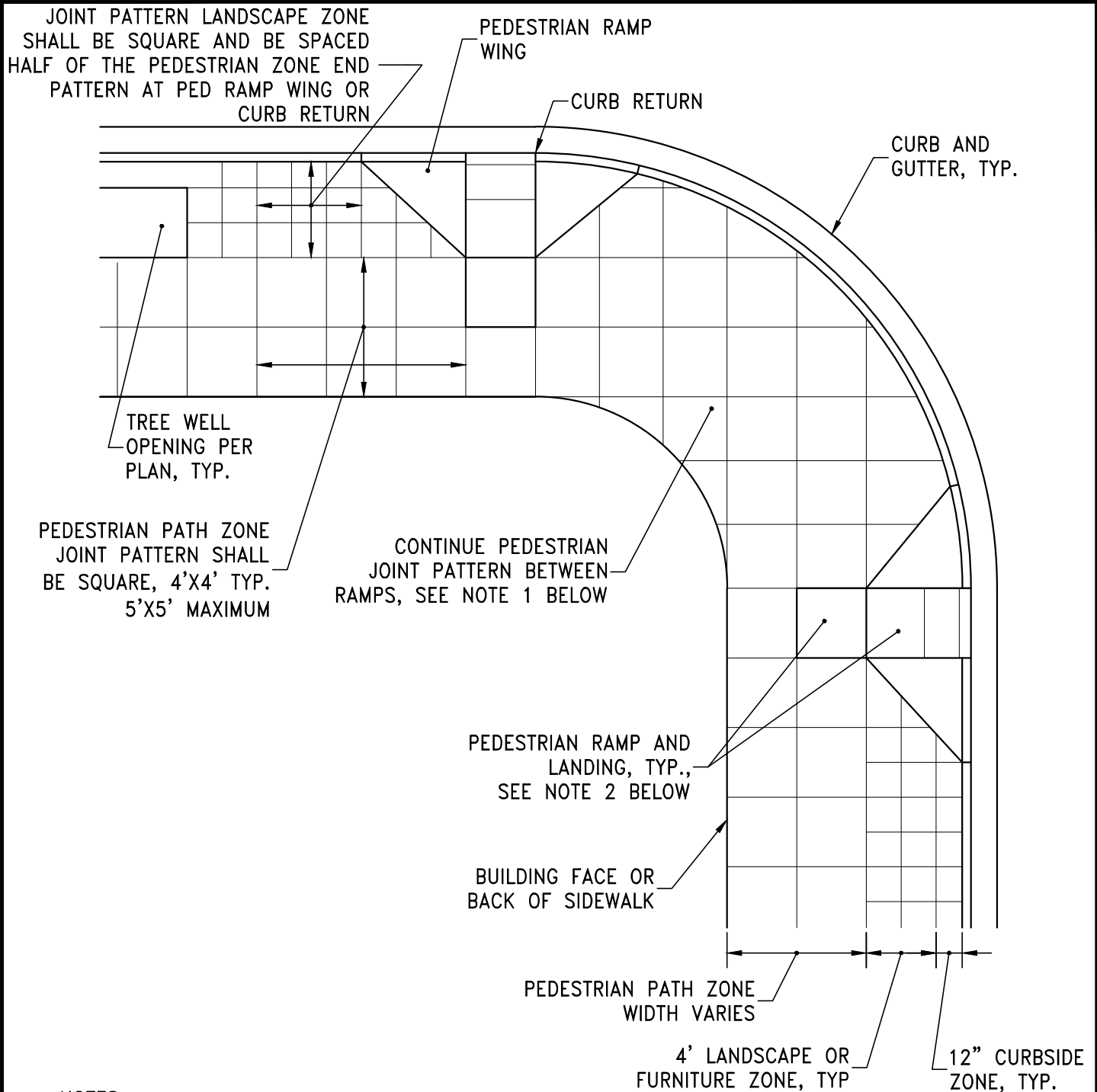

NOTES:

1. DETAIL IS INTEND FOR ILLUSTRATION OF JOINTING PATTERN FOR DECORATIVE SIDEWALK. THE JOINT PATTERNS ARE INTENDED TO BE SQUARE. SITE SPECIFIC JOINTS NECESSARY AT UTILITY BOXES AND VAULTS, POLES, DRIVEWAYS, PEDESTRIAN RAMPS, ETC., SHALL BE DETERMINED BY THE ENGINEER AND SHOWN ON THE IMPROVEMENT PLANS.
2. SEE CITY OF RENO STANDARD DETAILS FOR SIDEWALK AND PEDESTRIAN RAMP DETAILS AND SECTIONS. PEDESTRIAN RAMPS SHALL ALSO BE COLORED AND COMPLY WITH PUBLIC RIGHT-OF-WAY ACCESSIBILITY GUIDELINES (PROWAG) STANDARDS, CURRENT VERSION.



STANDARD DETAILS FOR PUBLIC WORKS CONSTRUCTION

**DECORATIVE COLORED P.C.C.
SIDEWALK JOINTING PATTERN**

DRAWING No.

R-104D

APPROVED BY: KK

DATE: 2/2026

GENERAL NOTES - DECORATIVE COLORED CONCRETE

1. PORTLAND CEMENT CONCRETE (P.C.C.) SHALL BE 4000 PSI MIN. COMPRESSIVE STRENGTH AT 28 DAYS. ALL CEMENT CONCRETE SHALL HAVE A COARSE AGGREGATE GRADATION CONFORMING TO SIZE No. 67. POLYPROPYLENE OR CELLULOSE FIBERS SHALL BE ADDED TO THE P.C.C. AT 1.5 LBS PER CUBIC YARD. MIX DESIGN SHALL CONFORM TO THE REQUIREMENTS OF SECTION 337.10 OF SSPWC. ALL MATERIALS SHALL CONFORM TO SSPWC.
2. ALL PEDESTRIAN RAMPS SHALL BE COLORED AND CONFORM TO THE REQUIREMENTS IN CITY OF RENO STANDARD DETAILS R-106A THROUGH R-106G.
3. AGGREGATE BASE MATERIAL UNDER SIDEWALKS, PEDESTRIAN RAMPS AND DRIVEWAYS SHALL BE TYPE 2, CLASS B CRUSHED AGGREGATE BASE. MATERIALS SHALL CONFORM TO SECTION 200 OF THE SSPWC.
4. ALL ADJACENT CONCRETE REMOVAL SHALL BE TO NEAT SAW CUT LINES AT RIGHT ANGLES TO NEW SIDEWALK. DOWEL INTO EXISTING ADJACENT CONCRETE SIDEWALK WITH A MINIMUM OF TWO (2) No. 4 REINFORCEMENT BARS EQUALLY SPACED ACROSS WIDTH "W" OF SIDEWALK. DOWELS SHALL PENETRATE A MINIMUM OF 4" INTO EXISTING CONCRETE.
5. STORM DRAIN INLETS OR SIMILAR ACCESSSES SHALL NOT BE LOCATED IN THE AREA AT THE BASE OF THE CURB RAMP OR LANDING AREA. IF OBSTRUCTIONS SUCH AS INLETS, UTILITY POLES, PULL BOXES, FIRE HYDRANTS, ETC. ARE ENCOUNTERED, THE LOCATION AND DIMENSIONS MAY BE ADJUSTED UPON APPROVAL OF THE ENGINEER.
6. GUTTER SHALL MAINTAIN POSITIVE DRAINAGE TO PREVENT PONDING.
7. ALL SLOPE RATES ARE RELATIVE TO LEVEL AND SHALL COMPLY WITH THE PUBLIC RIGHT-OF-WAY ACCESSIBILITY GUIDELINES (PROWAG) STANDARDS, CURRENT VERSION.
8. THE CONCRETE SHALL BE PLACED AND CONSOLIDATED SO AS TO COMPLETELY FILL SPACES IN THE FORMS AND TO PROVIDE SUITABLE SURFACE FOR FINISHING. THE CONCRETE ADJACENT TO THE FORMS SHALL BE SPADED. ALL SURROUNDING SURFACES OR WALLS SHALL BE PROTECTED TO PREVENT DISCOLORATION. WATER MUST NOT BE SPRAYED ON THE SURFACE TO RETEMPER THE PLASTIC CONCRETE FOR ADDITIONAL TROWELLING. HARD STEEL TROWELLING SHALL BE MINIMIZED TO AVOID TROWEL BURNS.



STANDARD DETAILS FOR PUBLIC WORKS CONSTRUCTION

DRAWING No.

GENERAL NOTES DECORATIVE COLORED
CONCRETE SIDEWALKS / DRIVEWAYS /
PEDESTRIAN RAMPS

R-104E

APPROVED BY: KK | DATE: 2/2026

TEST SECTION:

1. THE CONTRACTOR WILL BE REQUIRED TO CONSTRUCT A TEST SECTION AT THE PROJECT LOCATION FOR THE DECORATIVE COLORED CONCRETE SIDEWALK.
2. THE TEST SECTION WILL CONSIST OF A PORTION OF THE FINAL SIDEWALK WORK, FULL WIDTH AND A MINIMUM LENGTH OF 10 FEET. THE ENGINEER RESERVES THE RIGHT TO INCREASE THE LENGTH OF THE TEST SECTION TO 20 FEET IF THE SITUATION WARRANTS SUCH. THE CONTRACTOR MAY CONSTRUCT THE TEST SECTION BETWEEN EXPANSION JOINTS TO BECOME A PORTION TO THE FINAL SIDEWALK WORK. THE CONTRACTOR SHALL CONSTRUCT THE TEST SECTION TO DEMONSTRATE HIS ABILITY TO SUPPLY, PLACE, CONSOLIDATE, FINISH, CURE, TEXTURE, AND SEAL DECORATIVE CONCRETE. THE COLOR SHALL BE UNIFORM AND CONFORM TO THE CITY OF RENO'S COLOR SCHEME. THE JOINT LINES SHALL NOT BE SKEWED AND SHALL HAVE LINES THAT ARE CONTINUOUS ACROSS CONTRACTION AND EXPANSION JOINTS.
3. FOR ACCURATE COLOR, THE QUANTITY OF CONCRETE MIXED TO PRODUCE THE SAMPLE SHALL NOT BE LESS THAN 3 YD³ AND SHOULD BE IN FULL CUBIC YARD INCREMENTS. BATCH TICKETS SHALL INCLUDE A COMPLETE BREAK OUT OF ALL MATERIALS AND WEIGHTS FOR EACH.
4. ONCE ACCEPTED BY THE ENGINEER, THIS TEST SECTION SHALL REMAIN THROUGH THE COMPLETION OF THE WORK AND WILL BE A QUALITY STANDARD FOR JUDGING THE REMAINDER TO THE WORK. THE CONTRACTOR SHALL NOT COMMENCE WORK ON THE REMAINDER OF ANY OF THE DECORATIVE CONCRETE UNTIL THE TEST SECTION HAS BEEN COMPLETED AND ACCEPTED BY THE ENGINEER. THE CONTRACTOR MAY BE REQUIRED TO CONSTRUCT ADDITIONAL DECORATIVE CONCRETE TEST SECTIONS, IF THE INITIAL TEST SECTION IS NOT ACCEPTABLE. ALL DECORATIVE CONCRETE PLACED IN THE FINAL WORK SHALL BE ACCEPTED BASED ON THE CONTRACTOR'S ABILITY TO PRODUCE THE SAME QUALITY AS THAT SHOWN IN THE TEST SECTION AND IN ACCORDANCE WITH THE STANDARD SPECIFICATIONS AND THESE SPECIAL PROVISIONS.
5. AREAS NOT HAVING UNIFORM COLOR, STAMPING, OR OTHER SPECIFIED REQUIREMENTS SHALL BE REMOVED AND REPLACED AT THE CONTRACTOR'S EXPENSE.



STANDARD DETAILS FOR PUBLIC WORKS CONSTRUCTION

TEST SECTION DECORATIVE COLORED
CONCRETE SIDEWALKS / DRIVEWAYS /
PEDESTRIAN RAMPS

DRAWING No.

R-104F

APPROVED BY: KK | DATE: 2/2026

INTEGRALLY COLORED CONCRETE:

1. COLORS SHALL MATCH THE EXISTING COLORS ON VIRGINIA ST. (WEST SIDE) AND W. FIRST ST. FRENCH GRAY – ASHLAR COLOR
2. CONTRACTOR IS RESPONSIBLE FOR COLOR MATCH AND PROVIDING A TEST SECTION PER DETAIL R-104G. RECENTLY ACCEPTED COLORS (OR APPROVED EQUAL):
INCRETE SYSTEMS POWDER COLOR DARK GRAY (4 LBS PER SACK) – MATCH FRENCH GRAY
3. INTEGRAL COLORS SHALL MEET REQUIREMENTS OF ASTM C979.
4. LIQUID RELEASE SHALL CONSIST OF 100% MINERAL SPIRITS. THE SURFACE SHALL BE BROOM FINISHED (LIGHT) AND HAVE A FLAT SURFACE FINISH.
5. CURING AND SEALING SYSTEM SHALL BE A SOLVENT BASED, NON-YELLOWING, VOC COMPLIANT COMPOUND WITH ACRYLIC POLYMERS. THE CURING AND SEALING SYSTEM SHALL MEET THE FOLLOWING REQUIREMENTS: ASTM C-309 (TYPE 1, CLASS A), ASTM C1315 (TYPE 1, CLASS A, MINIMUM 25% SOLIDS CONTENT).
 - A. ALL COLORED CONCRETE TO BE SEALED SHALL BE SUFFICIENTLY CURED PRIOR TO APPLICATION OF SAID SEALANT. ALSO, ALL CAULKING AND EXPANSION JOINT WORK SHALL BE FULLY CURED PRIOR TO APPLICATION OF THE SEALANT. THE COVERAGE RATE SHALL BE 100 TO 125 SQUARE FEET PER GALLON, UNLESS OTHERWISE SPECIFIED BY THE MANUFACTURER AND APPROVED BY THE ENGINEER.
 - B. ALL MATERIALS SHALL BE DELIVERED IN THE ORIGINAL MANUFACTURER'S SEALED CONTAINERS. MATERIALS SHALL BE STORED TO PREVENT DAMAGE TO THE CONTAINERS. THE SEALER SHALL BE THOROUGHLY STIRRED BEFORE AND DURING USE. SURFACE, AIR AND MATERIAL TEMPERATURES SHALL NOT BE LESS THAN 50 DEGREES FAHRENHEIT DURING APPLICATION OR WITHIN 4 HOURS AFTER SAID APPLICATION. AREAS NOT SUBJECT TO NATURAL VENTILATION SHALL HAVE POSITIVE VENTILATION PROVIDED THROUGHOUT THE APPLICATION. PERSONNEL SHALL BE WARNED AGAINST PROLONGED BREATHING OF VAPORS AND CONTACT OF MATERIALS WITH THE SKIN OF EYES. PROTECT OTHER SURFACES NOT BEING SEALED AS NECESSARY DURING THE APPLICATION PROCESS.
 - C. THE CONTRACTOR SHALL NOT ALLOW FOOT OR VEHICULAR TRAFFIC ON SURFACES WHICH HAVE BEEN SEALED UNTIL SUCH TIME AS THEY ARE THOROUGHLY DRY, AS DETERMINED BY THE ENGINEER.



STANDARD DETAILS FOR PUBLIC WORKS CONSTRUCTION

INTEGRALLY DECORATIVE COLORED CONCRETE
SIDEWALKS / DRIVEWAYS / PED RAMPS
CURE AND SEAL

R-104G

APPROVED BY: KK | DATE: 2/2026

EXPANSION AND CONTROL JOINTS:

1. EXPANSION JOINTS AS SHOWN ON THE PLANS SHALL CONSIST OF A 1/2 INCH PREMOLDED EXPANSION JOINT WITH WHITE CAP OR BACKER ROD AND CAULK. THE PREMOLDED EXPANSION JOINT MATERIAL IS AN ASPHALT COATED FIBER EXPANSION JOINT, THE WHITE CAPE/BACKER IS A CLOSED BACKER ROD AND CAULK. WITHIN ROADWAY, THE CAULK SHALL BE A DOW CORNING 880 – SL SELF LEVELING SILICONE JOINT SEALANT OR APPROVED EQUAL. ALL OTHER LOCATIONS THE CAULK SHALL BE A SIKAFLEX 2C SL DEEP CHARCOAL OR APPROVED EQUAL. EXPANSION JOINTS (TRANSVERSE TO THE STREET CENTERLINE) SHALL BE CONSTRUCTED IN ALL CONCRETE SIDEWALKS, APPROACHES, DRIVEWAYS AT ALL CONSTRUCTION (COLD JOINTS) AND BETWEEN THE CONCRETE AND ANY EXISTING BUILDING. ALL JOINTS SHALL BE FILLED WITH THE PREMOLDED JOINT FILLER AS DESCRIBED ABOVE.
2. TRANSVERSE EXPANSION JOINTS 1/2 INCH WIDE SHALL BE CONSTRUCTED AT ALL SIDEWALK RETURNS OPPOSITE EXPANSION JOINTS IN ADJACENT CURB AND AT REGULAR INTERVALS NOT TO EXCEED 30 FEET. TRANSVERSE EXPANSION JOINTS SHALL ALSO BE CONSTRUCTED AT TRANSITION POINTS THAT WOULD NORMALLY CRACK DUE TO ANGLE POINTS OR SIMILAR OCCURRENCES. ISOLATION JOINTS SHALL BE INSTALLED AROUND ALL STRUCTURES.
3. SAWCUT JOINTS WILL BE REQUIRED BETWEEN EXPANSION JOINTS AS SPECIFIED:
 - A. FROM ALL ANGLE POINTS INCLUDING, BUT NOT LIMITED TO PULL BOXES, VAULTS, MANHOLES, PILLARS, DROP INLETS, STEEL INSERTS, STAIR WELLS, ETC., OR ANY ANGLE POINT FROM AN ADJOINING STRUCTURE.
 - B. SAW CUTS SHALL BE 1-1/4 INCH DEEP AND 1/8 INCH WIDE, PER DETAIL A BELOW. TRANSVERSE JOINTS AND LONGITUDINAL JOINTS SHALL HAVE 1/4" CHAMFERED EDGE. PRIOR TO CHAMFER EDGE CUT, CONCRETE SHALL BE ALLOWED TO CURE A MINIMUM OF 3 DAYS TO PREVENT "SPALDING" OF THE CHAMFER EDGE. DEVIATION OF CURE TIME SHALL BE APPROVED THE ENGINEER.
 - C. AREA BETWEEN SAWCUT AND EXPANSION (CONSTRUCTION) JOINTS SHALL BE SQUARE AND NOT TO EXCEED 100 SQUARE FEET.
4. WEAKENED PLANE JOINTS (TOOL JOINTS) AS SPECIFIED HEREINAFTER:
 - A. TOOL JOINTS SHALL MATCH THE DIMENSIONS OF SIDEWALK SCORE PATTERN, BE 1-1/4 INCH DEEP AND 1/4 INCH WIDE RADIUS AT THE TOP. ANY DEVIATIONS TO THESE REQUIREMENTS MUST BE APPROVED BY THE ENGINEER.
 - B. TOOL JOINTS SHALL BE LOCATED AT REGULAR INTERVALS NOT EXCEEDING 1.2 TIMES THE WIDTH AND NO MORE FREQUENTLY THAN 0.8 TIMES THE WIDTH. IN NO CASE SHALL REGULAR INTERVALS OF TOOL JOINTS IN EITHER DIRECTION EXCEED 10 FEET.



STANDARD DETAILS FOR PUBLIC WORKS CONSTRUCTION

DRAWING No.

EXPANSION AND CONTROL JOINTING
DECORATIVE COLORED CONCRETE
SIDEWALKS AND DRIVEWAYS

R-104H

APPROVED BY: KK | DATE: 2/2026

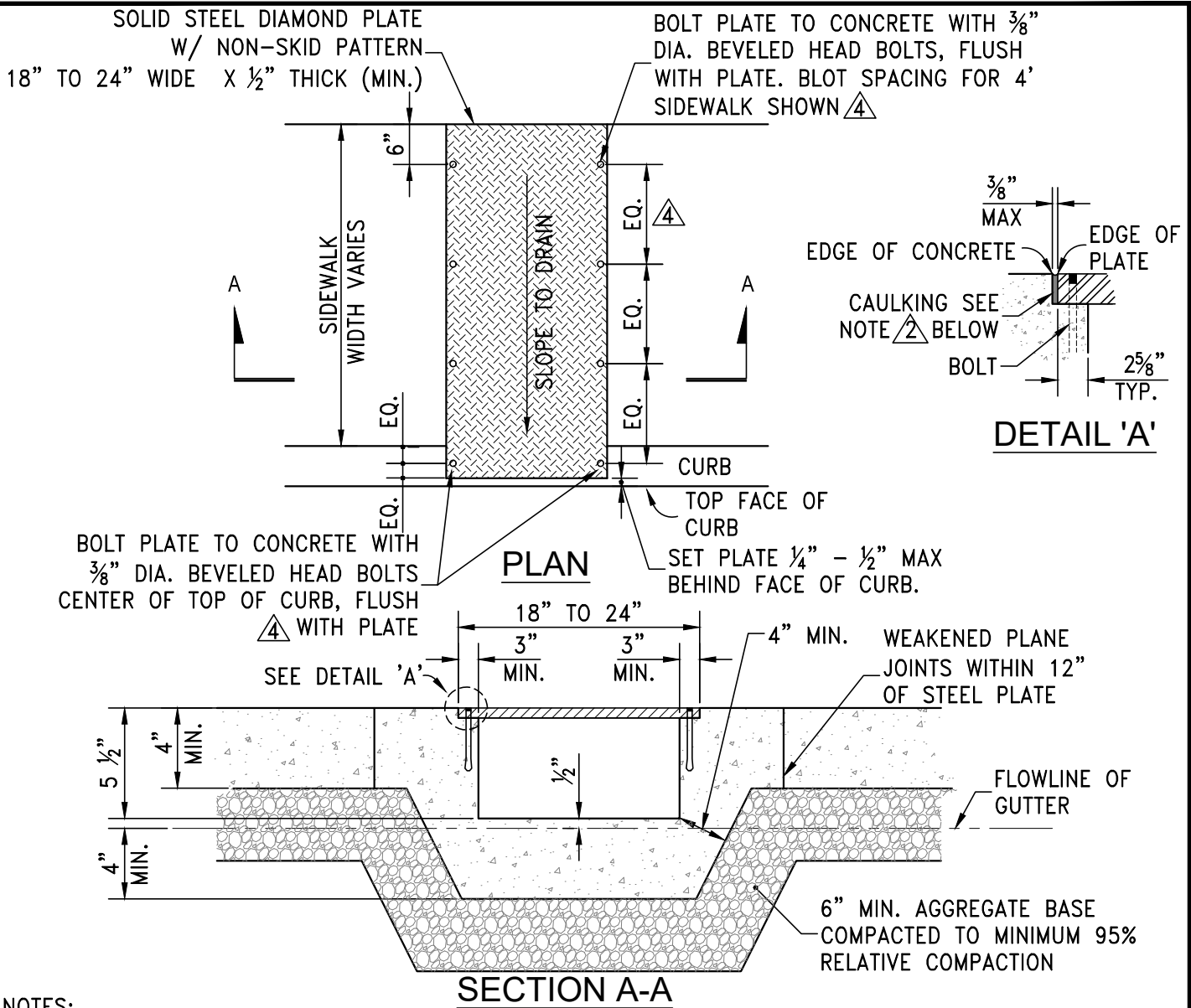

NOTES:

1. PORTLAND CEMENT CONCRETE (P.C.C.) SHALL BE 4000 PSI MIN. COMPRESSIVE STRENGTH AT 28 DAYS. ALL CEMENT CONCRETE SHALL HAVE A COARSE AGGREGATE GRADATION CONFORMING TO SIZE No. 67. POLYPROPYLENE OR CELLULOSE FIBERS SHALL BE ADDED TO THE P.C.C. AT 1.5 LBS PER CUBIC YARD. MIX DESIGN SHALL CONFORM TO THE REQUIREMENTS OF SECTION 337.10 OF SSPWC. ALL MATERIALS SHALL CONFORM TO SSPWC.
2. SET PLATE FLUSH WITH ADJACENT CONCRETE AND PROVIDE 3/8" MAX GAP BETWEEN STEEL PLATE AND EDGE OF SIDEWALK. FILL GAP WITH CAULKING AFTER PLACEMENT OF PLATE. CAULKING MATERIAL SHALL BE GE SILICONE II* W/D SUPREME, OR APPROVED EQUAL. COLOR SHALL BE WHITE.
3. AGGREGATE BASE MATERIAL UNDER CONCRETE DRAIN SUPPORT STRUCTURE SHALL BE TYPE 2, CLASS B CRUSHED AGGREGATE, ALL MATERIALS SHALL CONFORM TO SSPWC SECTION 200.
4. BOLTS: 3/8" DIA x 2 7/8" LONG DYNABOLT SLEEVE ANCHOR RAMSET REDHEAD FS-3826 OR APPROVED EQUIVALENT. SIDEWALK WIDER THAN 4FT, BOLTS SHALL BE PLACED AT 18" O.C. FOR WIDTH OF SIDEWALK



STANDARD DETAILS FOR PUBLIC WORKS CONSTRUCTION

DRAWING No.

SIDEWALK CROSS-DRAIN

R-105

APPROVED BY: KK

DATE: 2/2026

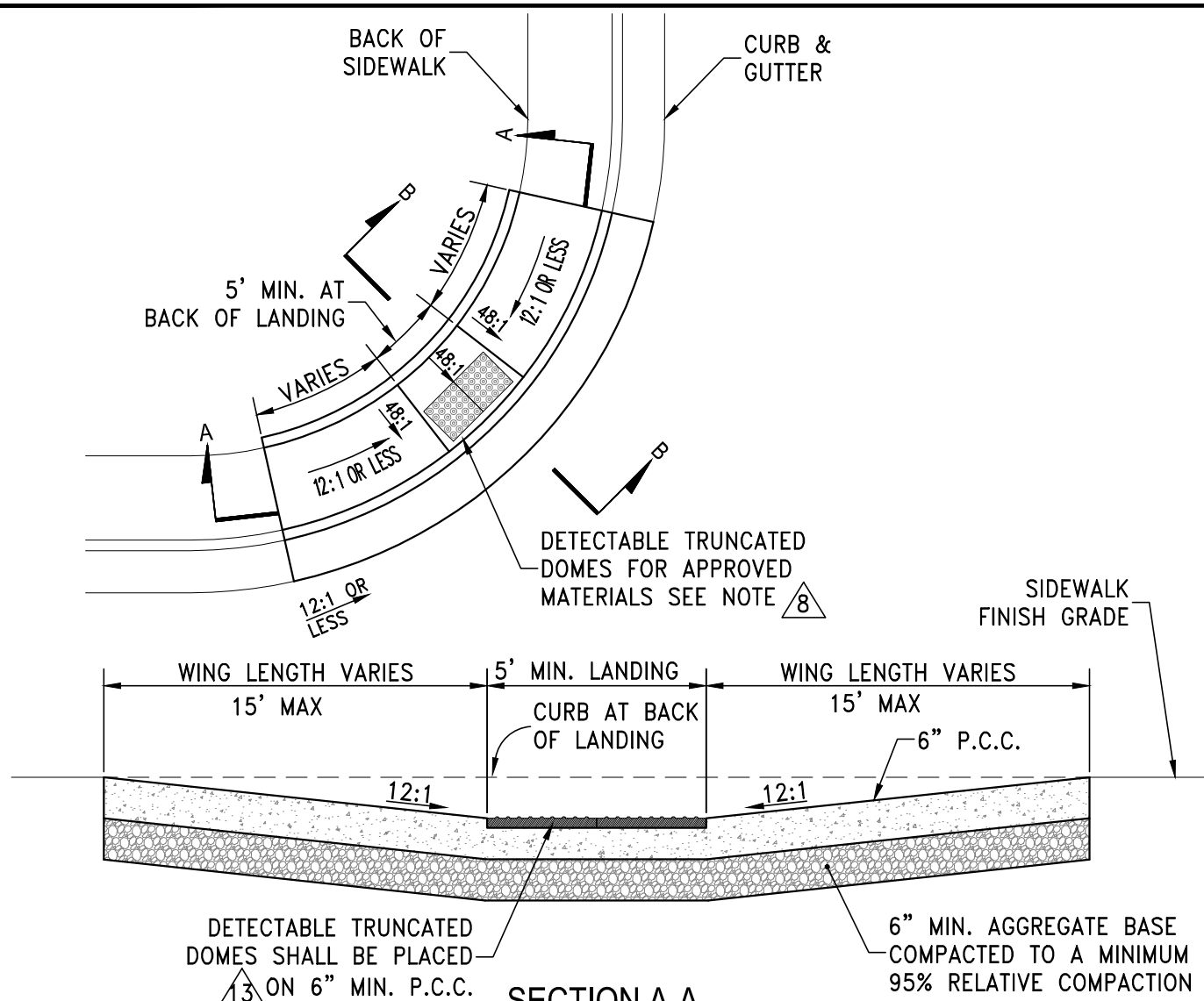

SECTION A-A

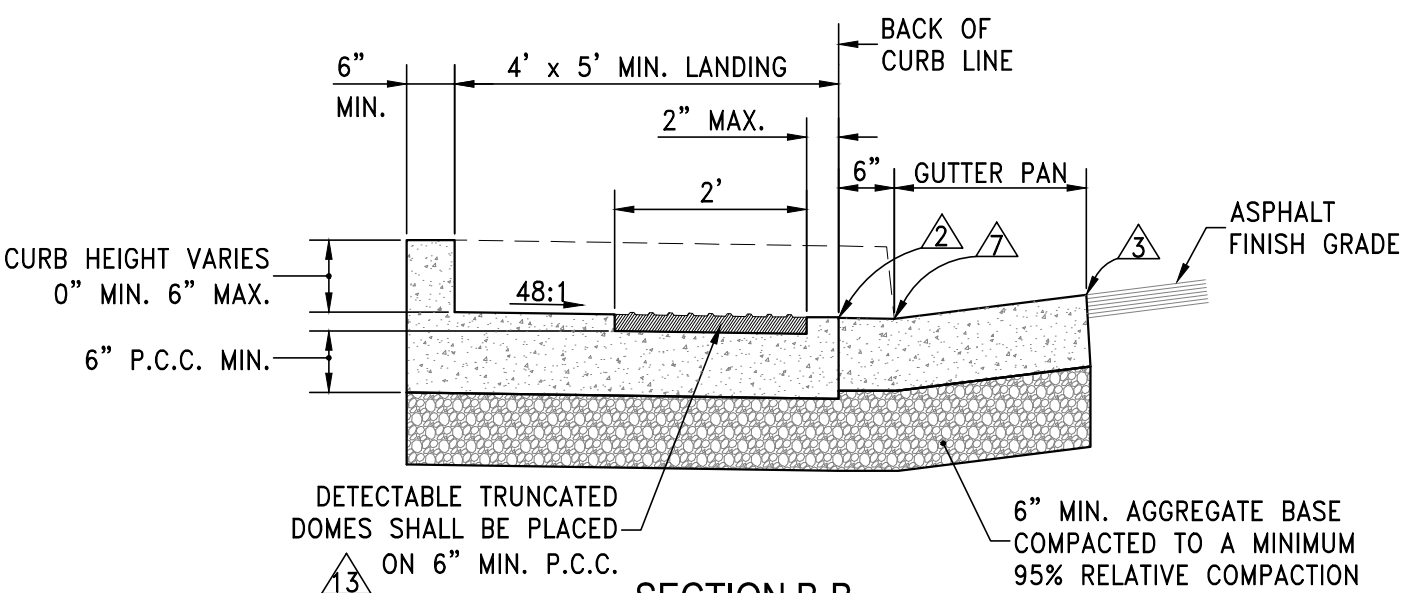

SECTION B-B



STANDARD DETAILS FOR PUBLIC WORKS CONSTRUCTION

**PEDESTRIAN RAMP -
EXISTING SIDEWALKS**

DRAWING No.

R-106A

APPROVED BY: KK | DATE: 2/2026

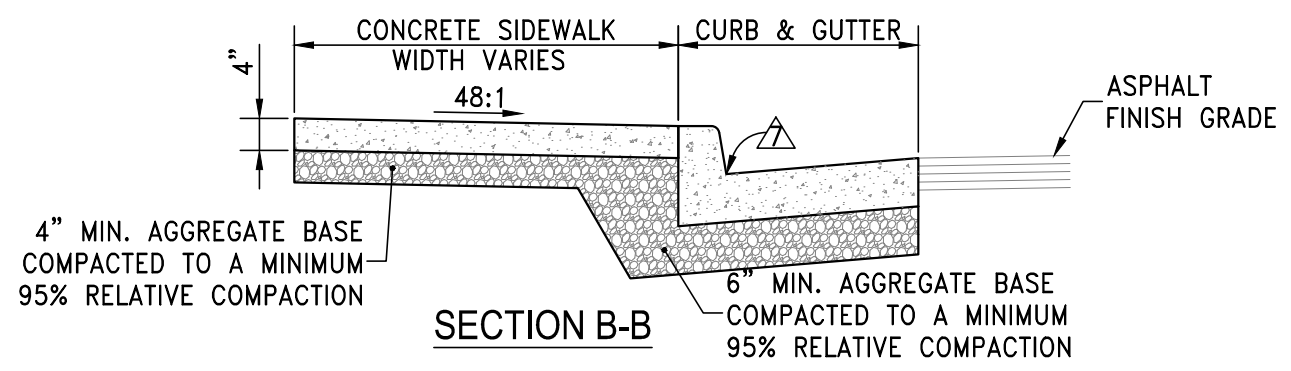
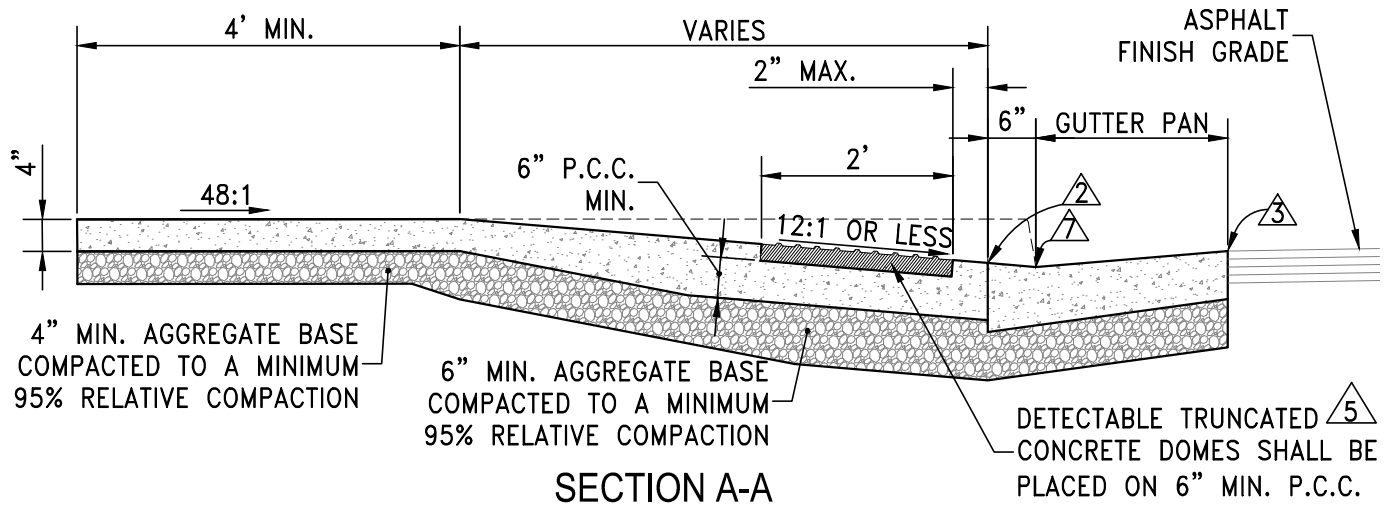
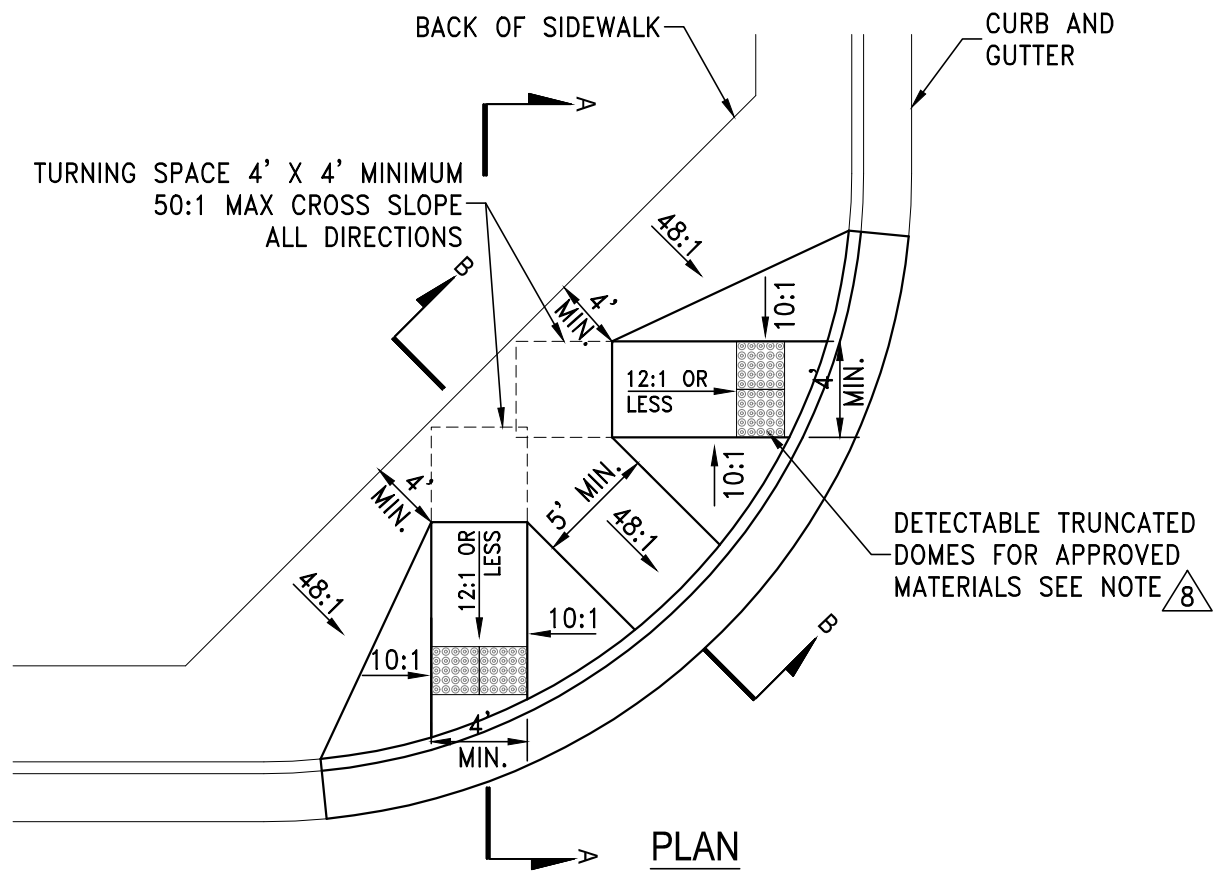

STANDARD DETAILS FOR PUBLIC WORKS CONSTRUCTION

DRAWING No.

**PEDESTRIAN RAMP -
NARROW SIDEWALKS**

R-106B

APPROVED BY: KK | DATE: 2/2026

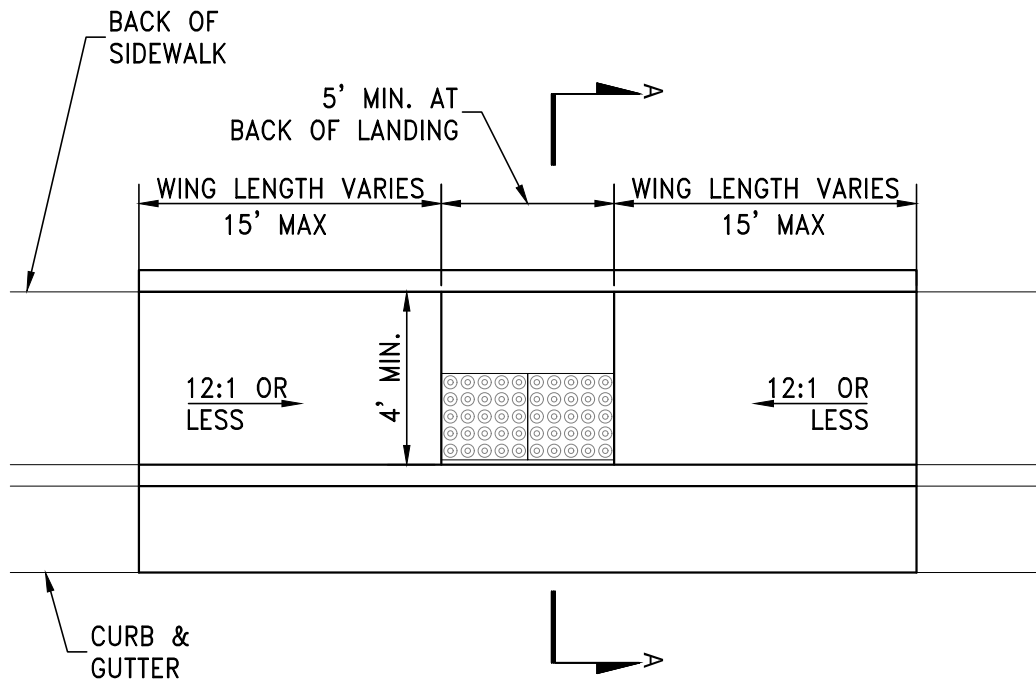

PLAN

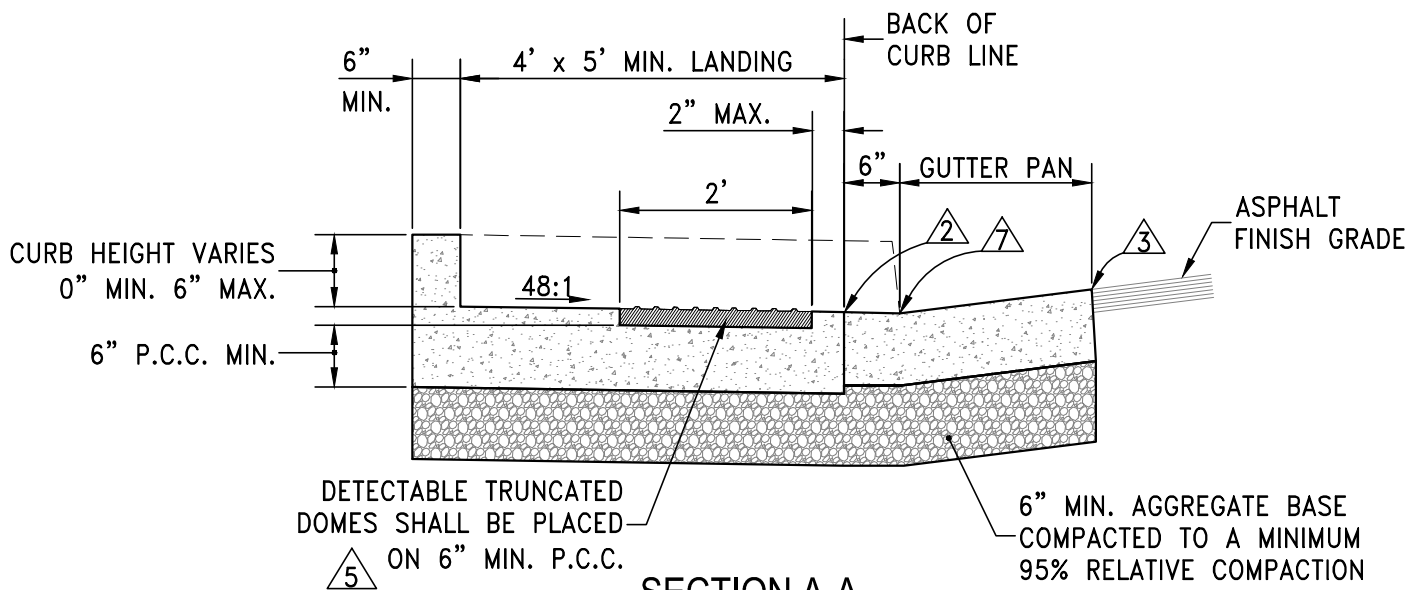

SECTION A-A



STANDARD DETAILS FOR PUBLIC WORKS CONSTRUCTION

**PEDESTRIAN RAMP
MIDBLOCK - TYPE 1**

DRAWING No.

R-106D

APPROVED BY: KK

DATE: 2/2026

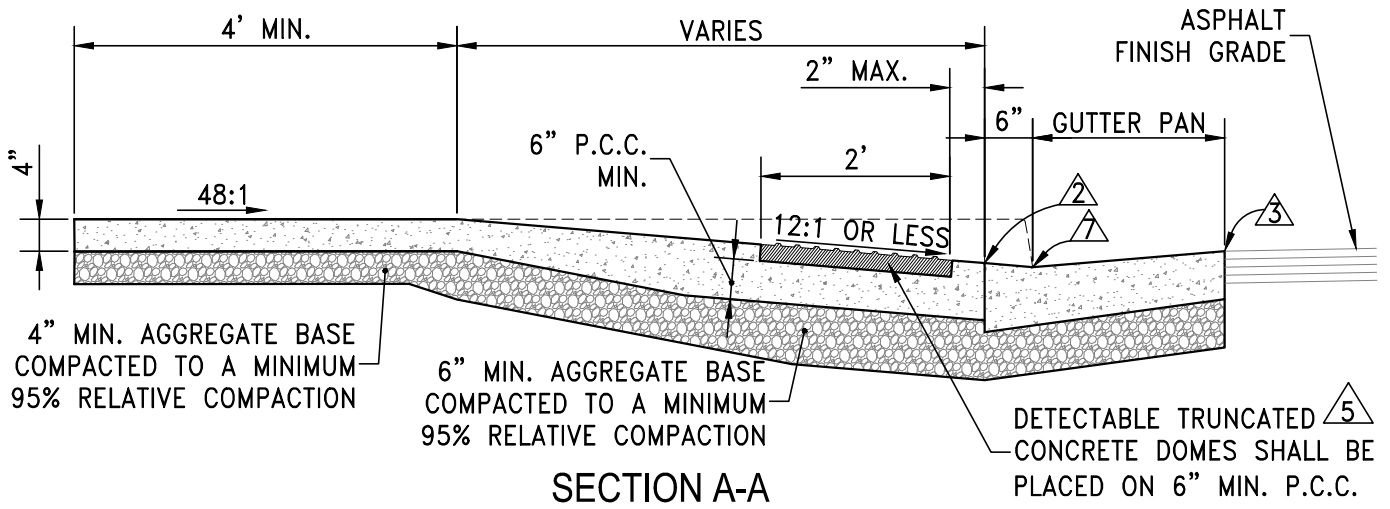
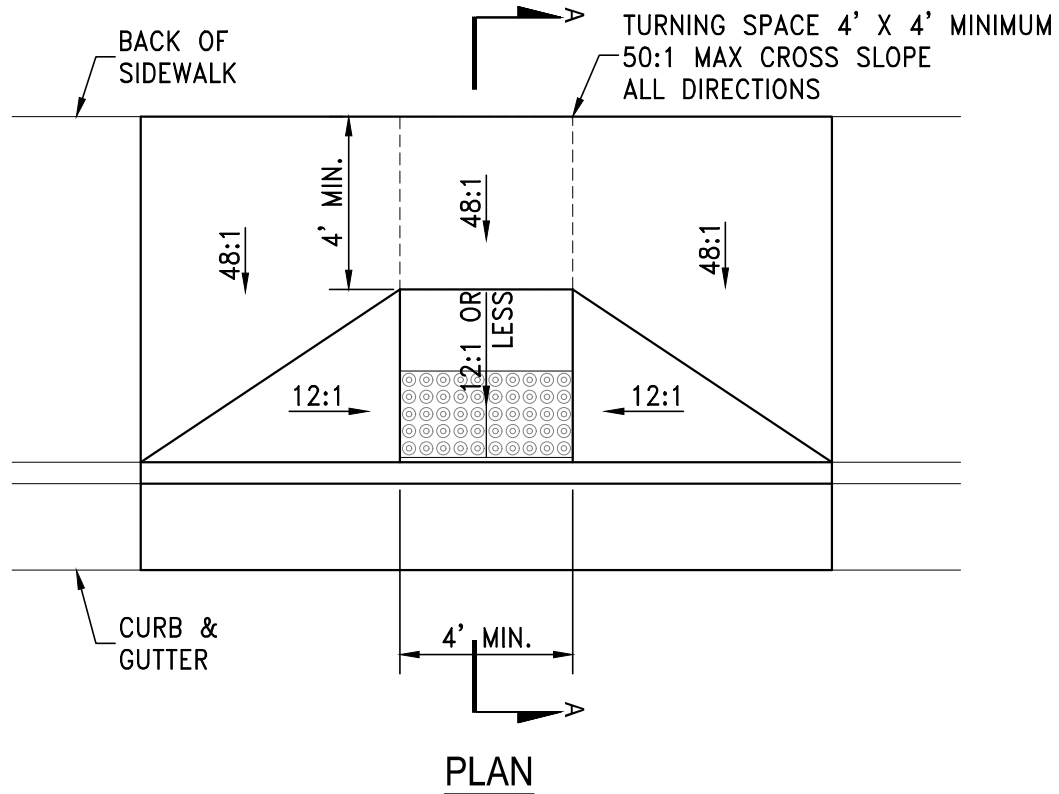

STANDARD DETAILS FOR PUBLIC WORKS CONSTRUCTION

PEDESTRIAN RAMP
MIDBLOCK - TYPE 2

DRAWING No.

R-106E

APPROVED BY: KK

DATE: 2/2026

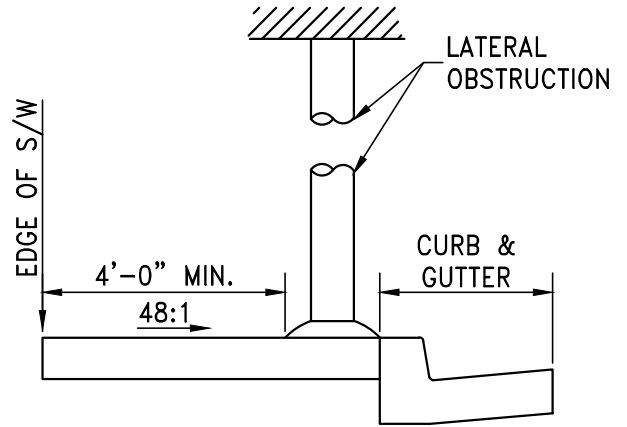
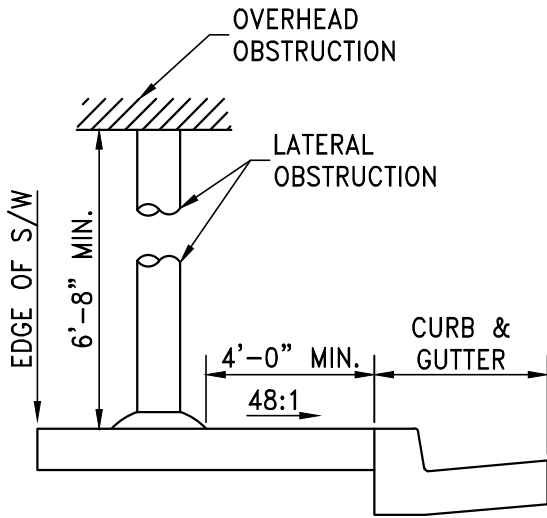

TYPICAL SIDEWALK vs OBSTRUCTION CLEARANCE DETAIL

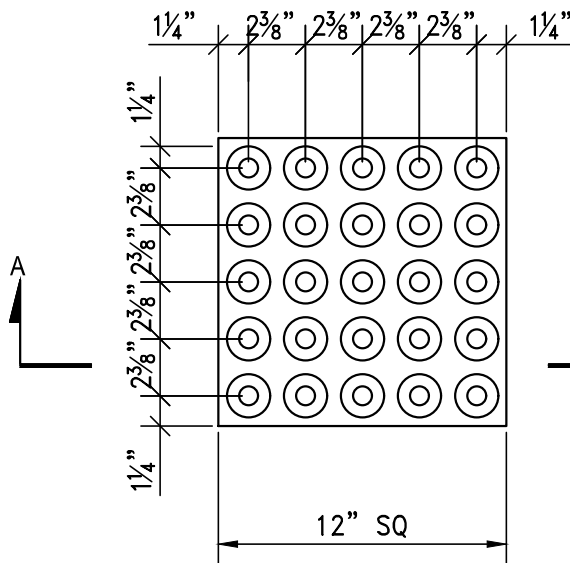

PLAN

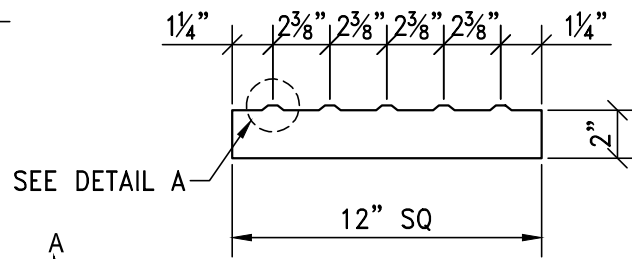

SECTION A-A

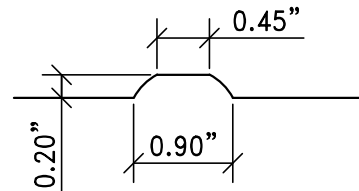

DETAIL A

NOTE: FOR DETECTABLE TRUNCATED DOMES APPROVED MATERIALS SEE NOTE 

TRUNCATED DOMES DETAIL



STANDARD DETAILS FOR PUBLIC WORKS CONSTRUCTION

**PEDESTRIAN RAMP -
DETAILS**

DRAWING No.

R-106F

APPROVED BY: KK

DATE: 2/2026

1. STORM DRAIN INLETS OR SIMILAR ACCESSES SHALL NOT BE LOCATED IN THE AREA AT THE BASE OF THE CURB RAMP OR LANDING AREA. IF OBSTRUCTIONS SUCH AS INLETS, UTILITY POLES, PULL BOXES, FIRE HYDRANTS, ETC. ARE ENCOUNTERED, THE LOCATION AND DIMENSIONS MAY BE ADJUSTED UPON APPROVAL OF THE ENGINEER.
2. NO LIP SHALL BE PERMITTED AT THE CURB RAMP SLOPE TO GUTTER PAN.
3. PLANTMIX BITUMINOUS SURFACE SHALL BE FLUSH WITH THE EDGE OF THE GUTTER PAN IN THE AREA OF THE CURB RAMP.
4. ROUGH BROOM TEXTURE ON CURB RAMPS AND WINGS.
5. DETECTABLE WARNING SHALL BE INSTALLED PER MANUFACTURER'S RECOMMENDATIONS AND SHALL BE PLACED ON MIN. SIX (6") INCHES OF P.C.C.
6. ALL SLOPE RATES ARE RELATIVE TO LEVEL AND SHALL COMPLY WITH THE PUBLIC RIGHT-OF-WAY ACCESSIBILITY GUIDELINES (PROWAG) STANDARDS, CURRENT VERSION.
7. GUTTER SHALL MAINTAIN POSITIVE DRAINAGE TO PREVENT PONDING.
8. DETECTABLE WARNING SHALL CONSIST OF PRECAST WETSET TILES WITH MIN. SIZE OF 2' X 2', COLOR DARK RED. APPROVED PRODUCTS INCLUDE: "ACCESS TILE", "TEKWAY DOME-TILES", "ADA SOLUTIONS", AND "TUFTILE". DETECTABLE WARNING SHALL BE CONSTRUCTED PER MANUFACTURER'S INSTALLATION GUIDELINES AND CONFORM TO PROWAG.
9. CONCRETE REMOVAL SHALL BE TO NEAT SAW CUT LINES AT NEAREST WEAKENED PLANE JOINT. NO OVERCUTS.
10. AGGREGATE BASE MATERIAL UNDER PEDESTRIAN RAMPS SHALL BE TYPE 2, CLASS B CRUSHED AGGREGATE BASE. MATERIALS SHALL CONFORM TO SSPWC SECTION 200.
11. PORTLAND CEMENT CONCRETE (P.C.C.) SHALL BE 4000 PSI MIN. COMPRESSIVE STRENGTH AT 28 DAYS. ALL CEMENT CONCRETE SHALL HAVE A COARSE AGGREGATE GRADATION CONFORMING TO SIZE No. 67. POLYPROPYLENE OR CELLULOSE FIBERS SHALL BE ADDED TO THE P.C.C. AT 1.5 LBS PER CUBIC YARD. MIX DESIGN SHALL CONFORM TO THE REQUIREMENTS OF SECTION 337.10 OF SSPWC. ALL MATERIALS SHALL CONFORM TO SSPWC.
12. CONTRACTORS SHALL CORRECT ANY GRADE CONFLICT WITH EXISTING BOXES. THE ENGINEER SHALL MAKE THE FINAL DETERMINATION REGARDING THE DEGREE OF MODIFICATIONS REQUIRED BY THE CONTRACTOR FOR GRADE CONFLICTS BETWEEN EXISTING BOXES AND NEW PEDESTRIAN RAMPS.
13. SIDEWALK AT BOTH SIDES OF RAMP MAY BE RECONSTRUCTED TO MINIMIZE THE GRADE AT A HORIZONTAL DISTANCE TO BE DETERMINED IN THE FIELD, UPON APPROVAL OF THE ENGINEER, SUBJECT TO PROWAG REQUIREMENTS. CURB AT THE BACK OF WALK MAY BE NEEDED. A TRANSITION SECTION OF SIDEWALK MAY BE NECESSARY TO MATCH CROSS SLOPE OF EXISTING SIDEWALK TO PEDESTRIAN RAMP IMPROVEMENTS. TRANSITION SECTIONS SHALL BE APPROVED BY THE ENGINEER PRIOR TO INSTALLATION.
14. CONTRACTOR SHALL CONSTRUCT ROUNDED CURBS WHERE THEY INTERSECT. RADIUS SHALL BE 1 FT MINIMUM MEASURED FROM FACE OF CURB. CURBS THAT INTERSECT AT A POINT SHALL NOT BE ALLOWED.



STANDARD DETAILS FOR PUBLIC WORKS CONSTRUCTION

DRAWING No.

NOTES - PEDESTRIAN RAMP

R-106G

APPROVED BY: KK

DATE: 2/2026

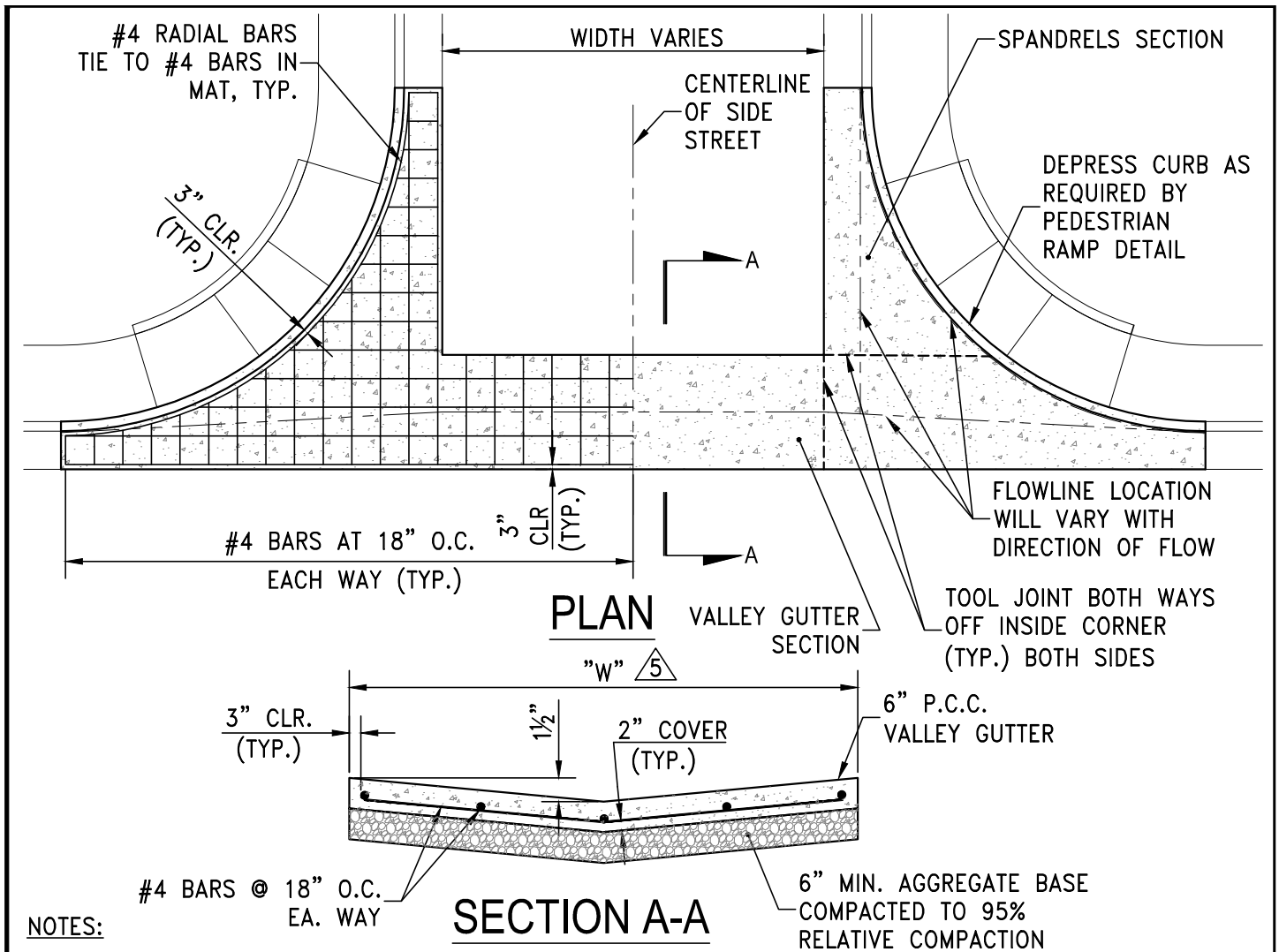

1. PORTLAND CEMENT CONCRETE (P.C.C.) SHALL BE 4000 PSI MIN. COMPRESSIVE STRENGTH AT 28 DAYS. ALL CEMENT CONCRETE SHALL HAVE A COARSE AGGREGATE GRADATION CONFORMING TO SIZE No. 67. POLYPROPYLENE OR CELLULOSE FIBERS SHALL BE ADDED TO THE P.C.C. AT 1.5 LBS PER CUBIC YARD. MIX DESIGN SHALL CONFORM TO THE REQUIREMENTS OF SECTION 337.10 OF SSPWC. ALL MATERIALS SHALL CONFORM TO SSPWC.
2. AGGREGATE BASE UNDER VALLEY GUTTER AND SPANDRELS SHALL BE TYPE 2, CLASS B CRUSHED AGGREGATE. ALL MATERIALS SHALL CONFORM TO SSPWC SECTION 200.
3. P.C.C VALLEY GUTTER DETAIL FOR RESIDENTIAL OR COMMERCIAL ZONES ONLY FOR OTHER APPLICATIONS AN ENGINEERED DESIGN IS REQUIRED.
4. VALLEY GUTTER SHALL HAVE WEAKENED PLANE JOINTS EVERY 10 FEET.
5. LOCAL AND COLLECTOR STREETS, "W"=6' MIN. ARTERIAL STREETS (DRIVEWAYS ONLY), "W"=10' MIN.
6. VALLEY GUTTER SECTIONS (SPANDRELS) ALONG CURB & GUTTER MAY BE A MONOLITHIC POUR AS SHOWN. DOWELS MATCHING REBAR SPACING SHOWN ARE REQUIRED FROM VALLEY GUTTER SECTION TO SPANDREL SECTION IF POURED SEPARATELY.

	STANDARD DETAILS FOR PUBLIC WORKS CONSTRUCTION	DRAWING No.
	P.C.C. VALLEY GUTTER	R-107
	APPROVED BY: KK	DATE: 1/2023

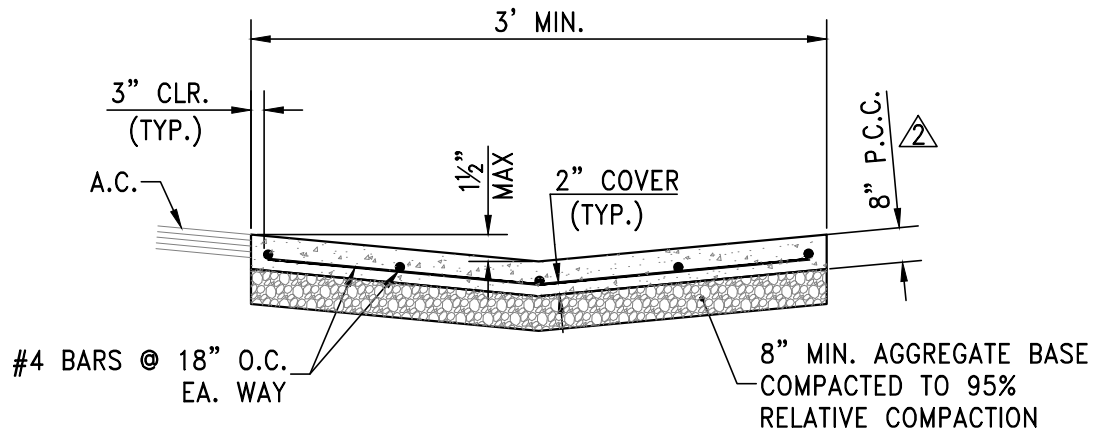

NOTES:

1. THIS GUTTER DESIGN IS FOR USE ON CITY STREETS.

2. PORTLAND CEMENT CONCRETE (P.C.C.) SHALL BE 4000 PSI MIN. COMPRESSIVE STRENGTH AT 28 DAYS. ALL CEMENT CONCRETE SHALL HAVE A COARSE AGGREGATE GRADATION CONFORMING TO SIZE No. 67. POLYPROPYLENE OR CELLULOSE FIBERS SHALL BE ADDED TO THE P.C.C. AT 1.5 LBS PER CUBIC YARD. MIX DESIGN SHALL CONFORM TO THE REQUIREMENTS OF SECTION 337.10 OF SSPWC. ALL MATERIALS SHALL CONFORM TO SSPWC.

3. AGGREGATE BASE MATERIAL UNDER SIDEWALKS SHALL BE TYPE 2, CLASS B CRUSHED AGGREGATE BASE. MATERIALS SHALL CONFORM TO SSPWC SECTION 200.



STANDARD DETAILS FOR PUBLIC WORKS CONSTRUCTION

DRAWING No.

**LONGITUDINAL
P.C.C. VALLEY GUTTER**

R-108

APPROVED BY: KK | DATE: 1/2023

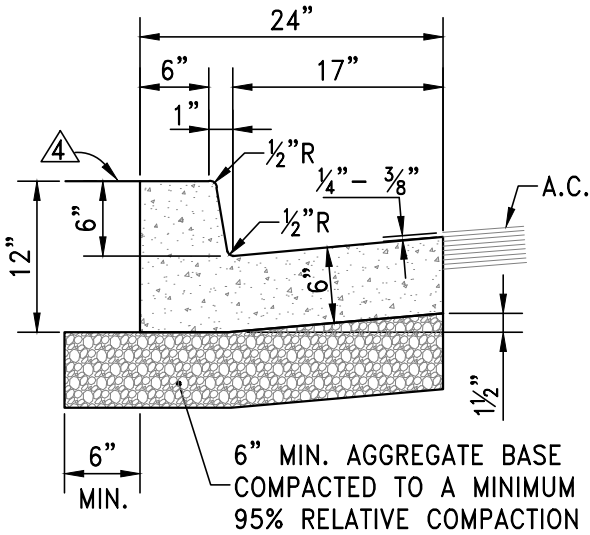

TYPE 1

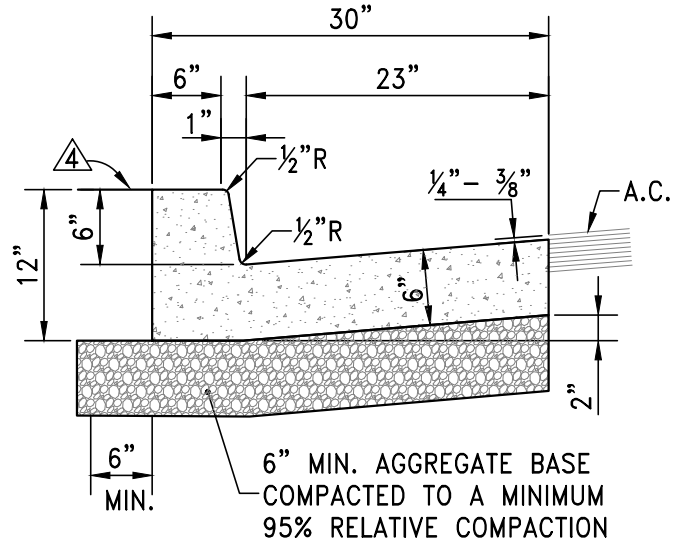

TYPE 1A

NOTES:

1. PORTLAND CEMENT CONCRETE (P.C.C.) SHALL BE 4000 PSI MIN. COMPRESSIVE STRENGTH AT 28 DAYS. ALL CEMENT CONCRETE SHALL HAVE A COARSE AGGREGATE GRADATION CONFORMING TO SIZE No. 67. POLYPROPYLENE OR CELLULOSE FIBERS SHALL BE ADDED TO THE P.C.C. AT 1.5 LBS PER CUBIC YARD. MIX DESIGN SHALL CONFORM TO THE REQUIREMENTS OF SECTION 337.10 OF SSPWC. ALL MATERIALS SHALL CONFORM TO SSPWC.
2. AGGREGATE BASE MATERIAL UNDER AND BEHIND CURB AND GUTTER SHALL BE TYPE 2, CLASS B CRUSHED AGGREGATE BASE. MATERIALS SHALL CONFORM TO SSPWC SECTION 200.
3. WEAKENED PLANE JOINTS SHALL BE EVERY 10 FEET AND LOCATED ON THE BACK, TOP AND FACE OF THE CURB AND THE TOP OF THE GUTTER PAN.
4. CURB & GUTTER SECTIONS SHALL BE PLACED SEPARATELY FROM SIDEWALK SECTIONS. WHEN SIDEWALK IS NOT REQUIRED DIRECTLY BEHIND THE CURB, BACKFILL TO TOP OF CURB FOR A HORIZONTAL DISTANCE OF 12" FROM BACK FACE OF CURB AND COMPACT TO 90% RELATIVE COMPACTION.
5. FOR REPLACEMENT OF EXISTING CURB AND GUTTER, MATCH EXISTING TYPE. ALL ADJACENT CONCRETE REMOVAL SHALL BE TO NEAT SAW CUT LINES AT RIGHT ANGLES TO NEW CURB AND GUTTER AT NEAREST WEAKENED PLANE JOINT.
6. TUNNELING AND/OR BORING IS NOT ALLOWED. REFER TO R-120 FOR ASPHALT PATCHING AGAINST CURB.



STANDARD DETAILS FOR PUBLIC WORKS CONSTRUCTION

DRAWING No.

**P.C.C. TYPE 1
CURB & GUTTER**

R-109A

APPROVED BY: KK | DATE: 2/2026

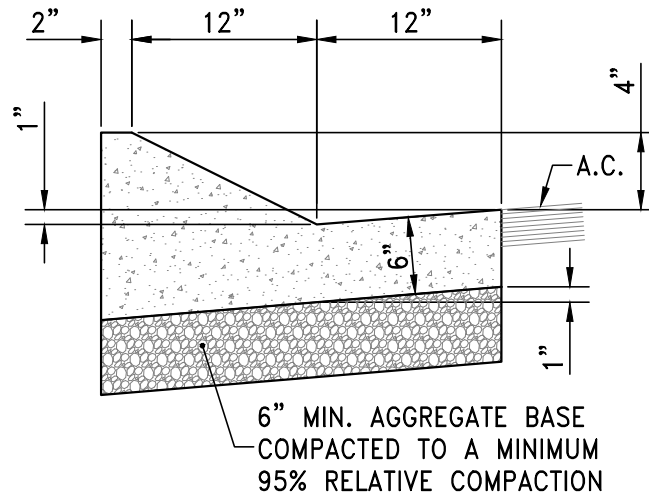

TYPE E PCC CURB & GUTTER

NOTES:

1. FOR USE WITH NEW DEVELOPMENT CONSTRUCTION. REQUIRES APPROVAL THROUGH ENTITLEMENT OR CITY ENGINEER. A MINIMUM 5' WIDE THICKENED SIDEWALK CONSISTING OF 6" P.C.C. AND 6" AGGREGATE BASE SHALL BE REQUIRED. APPROPRIATE HYDRAULIC ANALYSIS AND GUTTER SPREAD CALCULATIONS SHALL BE PROVIDED PRIOR TO USE.
2. PORTLAND CEMENT CONCRETE (P.C.C.) SHALL BE 4000 PSI MIN. COMPRESSIVE STRENGTH AT 28 DAYS. ALL CEMENT CONCRETE SHALL HAVE A COARSE AGGREGATE GRADATION CONFORMING TO SIZE No. 67. POLYPROPYLENE OR CELLULOSE FIBERS SHALL BE ADDED TO THE P.C.C. AT 1.5 LBS PER CUBIC YARD. MIX DESIGN SHALL CONFORM TO THE REQUIREMENTS OF SECTION 337.10 OF SSPWC. ALL MATERIALS SHALL CONFORM TO SSPWC.
3. AGGREGATE BASE MATERIAL UNDER AND BEHIND CURB AND GUTTER SHALL BE TYPE 2, CLASS B CRUSHED AGGREGATE BASE. MATERIALS SHALL CONFORM TO SSPWC SECTION 200.
4. WEAKENED PLANE JOINTS SHALL BE EVERY 10 FEET AND LOCATED ON THE BACK, TOP AND FACE OF THE CURB AND THE TOP OF THE GUTTER PAN.
5. CURB & GUTTER SECTIONS SHALL BE PLACED SEPARATELY FROM SIDEWALK SECTIONS. WHEN SIDEWALK IS NOT REQUIRED DIRECTLY BEHIND THE CURB, BACKFILL TO TOP OF CURB FOR A HORIZONTAL DISTANCE OF 12" FROM BACK FACE OF CURB AND COMPACT TO 90% RELATIVE COMPACTION.
6. FOR REPLACEMENT OF EXISTING CURB AND GUTTER, MATCH EXISTING TYPE. ALL ADJACENT CONCRETE REMOVAL SHALL BE TO NEAT SAW CUT LINES AT RIGHT ANGLES TO NEW CURB AND GUTTER AT NEAREST WEAKENED PLANE JOINT.
7. TUNNELING AND/OR BORING IS NOT ALLOWED. REFER TO R-120 FOR ASPHALT PATCHING AGAINST CURB.



STANDARD DETAILS FOR PUBLIC WORKS CONSTRUCTION

DRAWING No.

**P.C.C. TYPE E
CURB & GUTTER**

R-109B

APPROVED BY: KK | DATE: 2/2026

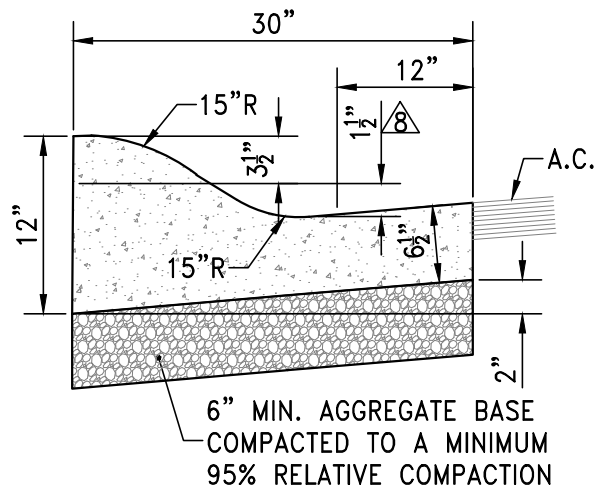

TYPE R ROLLED CURB & GUTTER

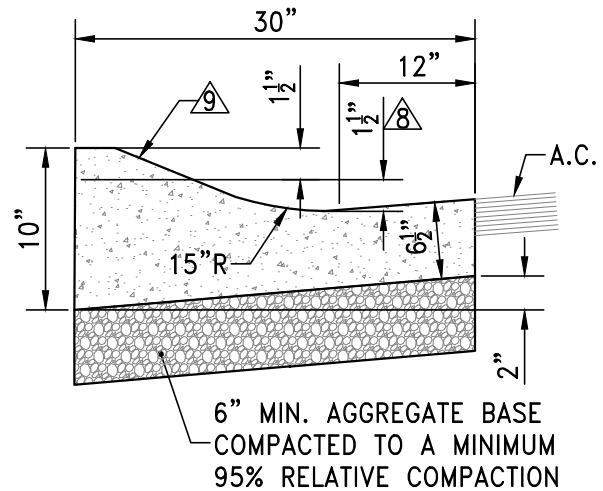

TYPE R DRIVEWAY ROLLED CURB & GUTTER

NOTES:

1. FOR USE IN CITY INITIATED NEIGHBORHOOD STREET REHABILITATION ONLY. REQUIRES APPROVAL THROUGH CITY ENGINEER. APPROPRIATE HYDRAULIC ANALYSIS AND GUTTER SPREAD CALCULATIONS SHALL BE PROVIDED PRIOR TO USE.
2. PORTLAND CEMENT CONCRETE (P.C.C.) SHALL BE 4000 PSI MIN. COMPRESSIVE STRENGTH AT 28 DAYS. ALL CEMENT CONCRETE SHALL HAVE A COARSE AGGREGATE GRADATION CONFORMING TO SIZE No. 67. POLYPROPYLENE OR CELLULOSE FIBERS SHALL BE ADDED TO THE P.C.C. AT 1.5 LBS PER CUBIC YARD. MIX DESIGN SHALL CONFORM TO THE REQUIREMENTS OF SECTION 337.10 OF SSPWC. ALL MATERIALS SHALL CONFORM TO SSPWC.
3. AGGREGATE BASE MATERIAL UNDER AND BEHIND CURB AND GUTTER SHALL BE TYPE 2, CLASS B CRUSHED AGGREGATE BASE. MATERIALS SHALL CONFORM TO SSPWC SECTION 200.
4. WEAKENED PLANE JOINTS SHALL BE EVERY 10 FEET AND LOCATED ON THE BACK, TOP AND FACE OF THE CURB AND THE TOP OF THE GUTTER PAN.
5. CURB & GUTTER SECTIONS SHALL BE PLACED SEPARATELY FROM SIDEWALK SECTIONS. WHEN SIDEWALK IS NOT REQUIRED DIRECTLY BEHIND THE CURB, BACKFILL TO TOP OF CURB FOR A HORIZONTAL DISTANCE OF 12" FROM BACK FACE OF CURB AND COMPACT TO 90% RELATIVE COMPACTION.
6. FOR REPLACEMENT OF EXISTING CURB AND GUTTER, MATCH EXISTING TYPE. ALL ADJACENT CONCRETE REMOVAL SHALL BE TO NEAT SAW CUT LINES AT RIGHT ANGLES TO NEW CURB AND GUTTER AT NEAREST WEAKENED PLANE JOINT.
7. TUNNELING AND/OR BORING IS NOT ALLOWED. REFER TO R-120 FOR ASPHALT PATCHING AGAINST CURB.

⚠️ 1 1/2" VERTICAL OFFSET FROM LIP TO FLOW LINE.

⚠️ AT DRIVEWAYS, CONTRACTOR SHALL REMOVE RADIUS AND CUT RAMP AT FRONT OF DRIVEWAY CURB.



STANDARD DETAILS FOR PUBLIC WORKS CONSTRUCTION

DRAWING No.

**P.C.C. TYPE R
CURB & GUTTER**

R-109C

APPROVED BY: KK | DATE: 2/2026

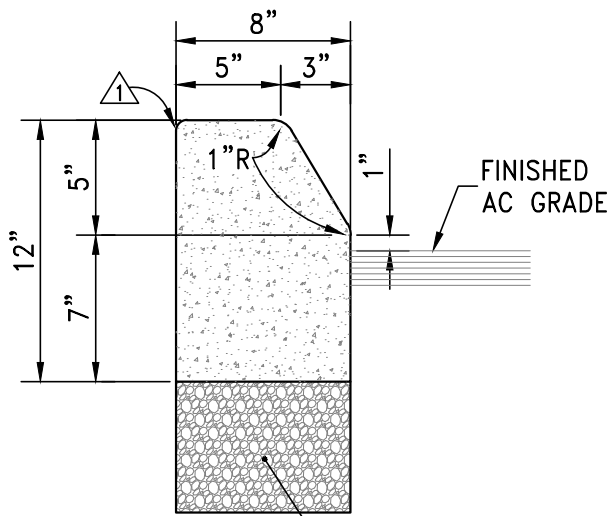

TYPE 2 P.C.C. MEDIAN CURB

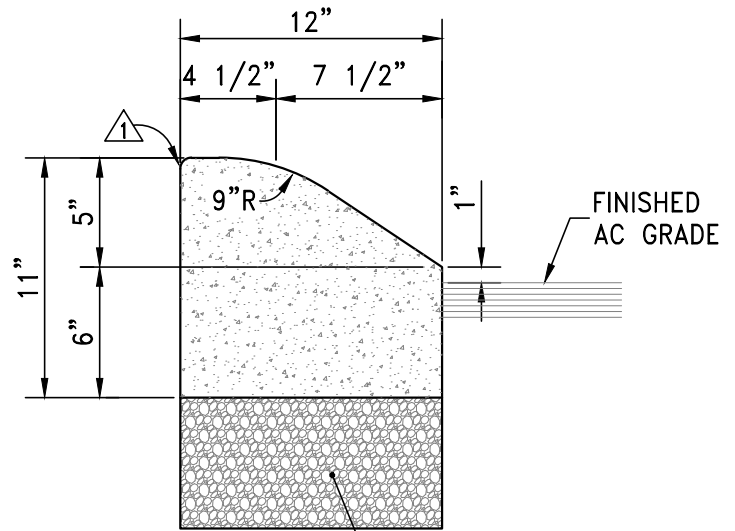

TYPE 3 P.C.C. MEDIAN CURB

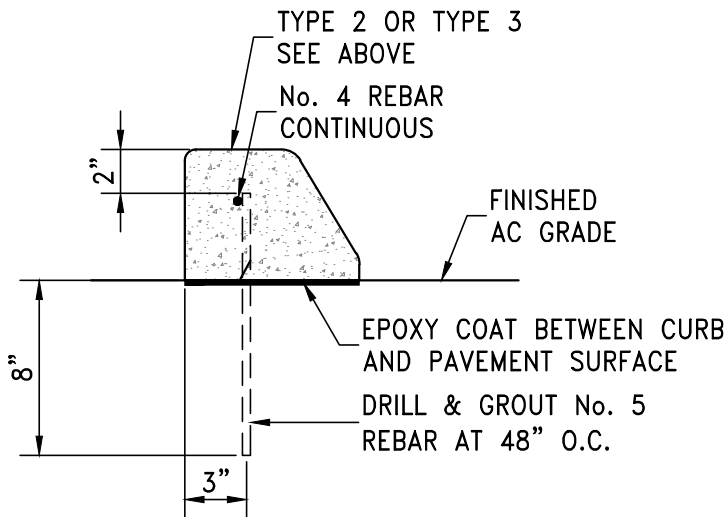

P.C.C. MEDIAN CURB (ALTERNATE)

NOTES:

△ RADIUS TO BE 1/2 INCH, OMIT ROUNDING IF CURBS ARE BACK TO BACK.

2. PORTLAND CEMENT CONCRETE (P.C.C.) SHALL BE 4000 PSI MIN. COMPRESSIVE STRENGTH AT 28 DAYS. ALL CEMENT CONCRETE SHALL HAVE A COARSE AGGREGATE GRADATION CONFORMING TO SIZE No. 67. POLYPROPYLENE OR CELLULOSE FIBERS SHALL BE ADDED TO THE P.C.C. AT 1.5 LBS PER CUBIC YARD. MIX DESIGN SHALL CONFORM TO THE REQUIREMENTS OF SECTION 337.10 OF SSPWC. ALL MATERIALS SHALL CONFORM TO SSPWC.
3. AGGREGATE BASE MATERIAL UNDER MEDIAN CURBS SHALL BE TYPE 2, CLASS B CRUSHED AGGREGATE BASE. MATERIALS SHALL CONFORM TO SSPWC SECTION 200.



STANDARD DETAILS FOR PUBLIC WORKS CONSTRUCTION

DRAWING No.

P.C.C. MEDIAN CURBS

R-110

APPROVED BY: KK

DATE: 1/2023

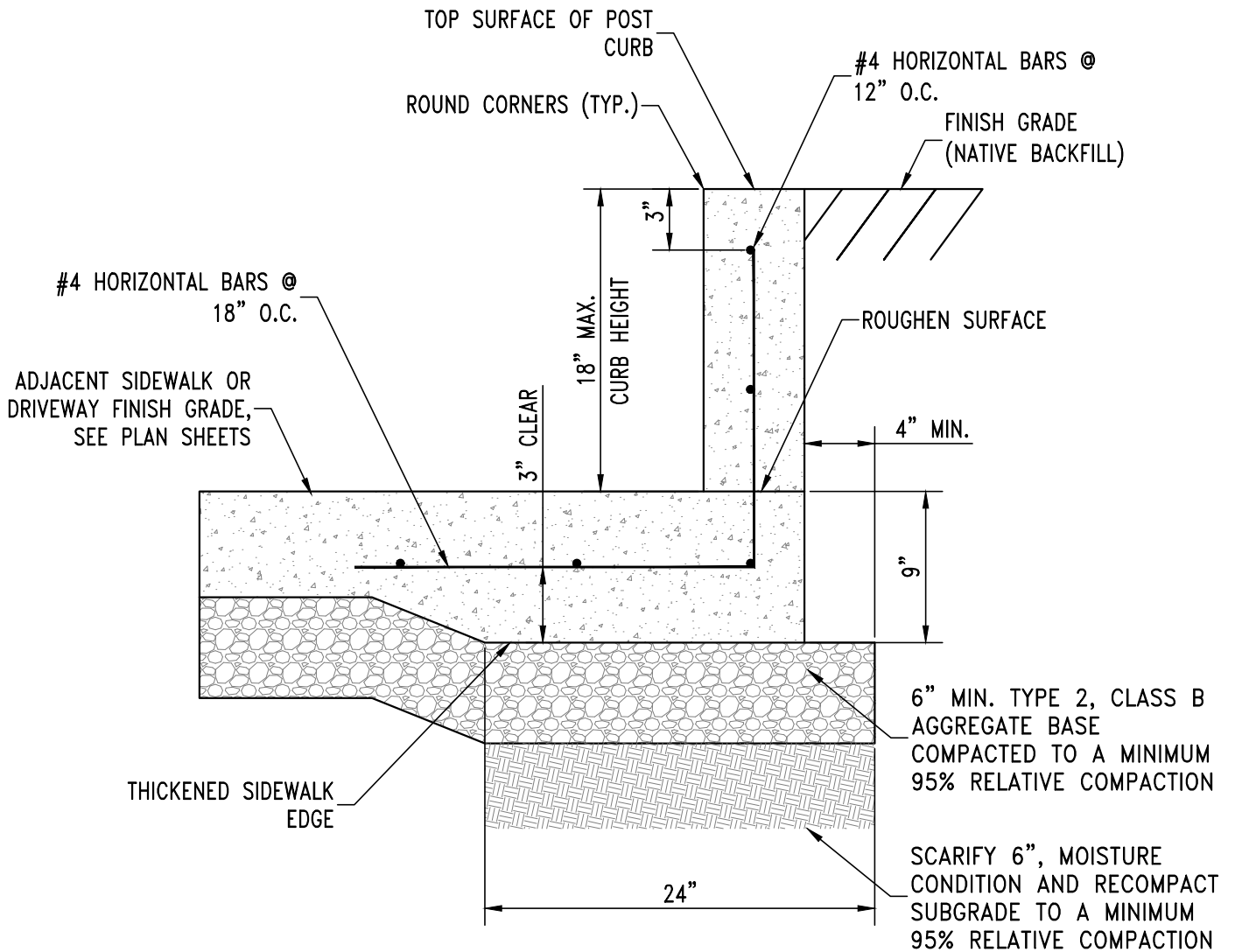

NOTES:

1. PORTLAND CEMENT CONCRETE (P.C.C.) SHALL BE 4000 PSI MIN. COMPRESSIVE STRENGTH AT 28 DAYS. ALL CEMENT CONCRETE SHALL HAVE A COARSE AGGREGATE GRADATION CONFORMING TO SIZE No. 67. POLYPROPYLENE OR CELLULOSE FIBERS SHALL BE ADDED TO THE P.C.C. AT 1.5 LBS PER CUBIC YARD. MIX DESIGN SHALL CONFORM TO THE REQUIREMENTS OF SECTION 337.10 OF SSPWC. ALL MATERIALS SHALL CONFORM TO SSPWC.
2. AGGREGATE BASE MATERIAL UNDER AND BEHIND CURB AND GUTTER SHALL BE TYPE 2, CLASS B CRUSHED AGGREGATE BASE. ALL MATERIALS SHALL CONFORM TO SSPWC.
3. WEAKENED PLANE JOINTS SHALL MATCH THE SPACING OF ADJACENT SIDEWALK OR DRIVEWAY AND IN ACCORDANCE WITH SECTION 312 OF SSPWC.
4. SIDEWALK AND/OR DRIVEWAY SECTIONS MAY BE PLACED MONOLITHICALLY WITH POST CURB SECTIONS.



STANDARD DETAILS FOR PUBLIC WORKS CONSTRUCTION

**P.C.C. REINFORCED
RETAINING CURB**

DRAWING No.

R-111

APPROVED BY: KK

DATE: 2/2026

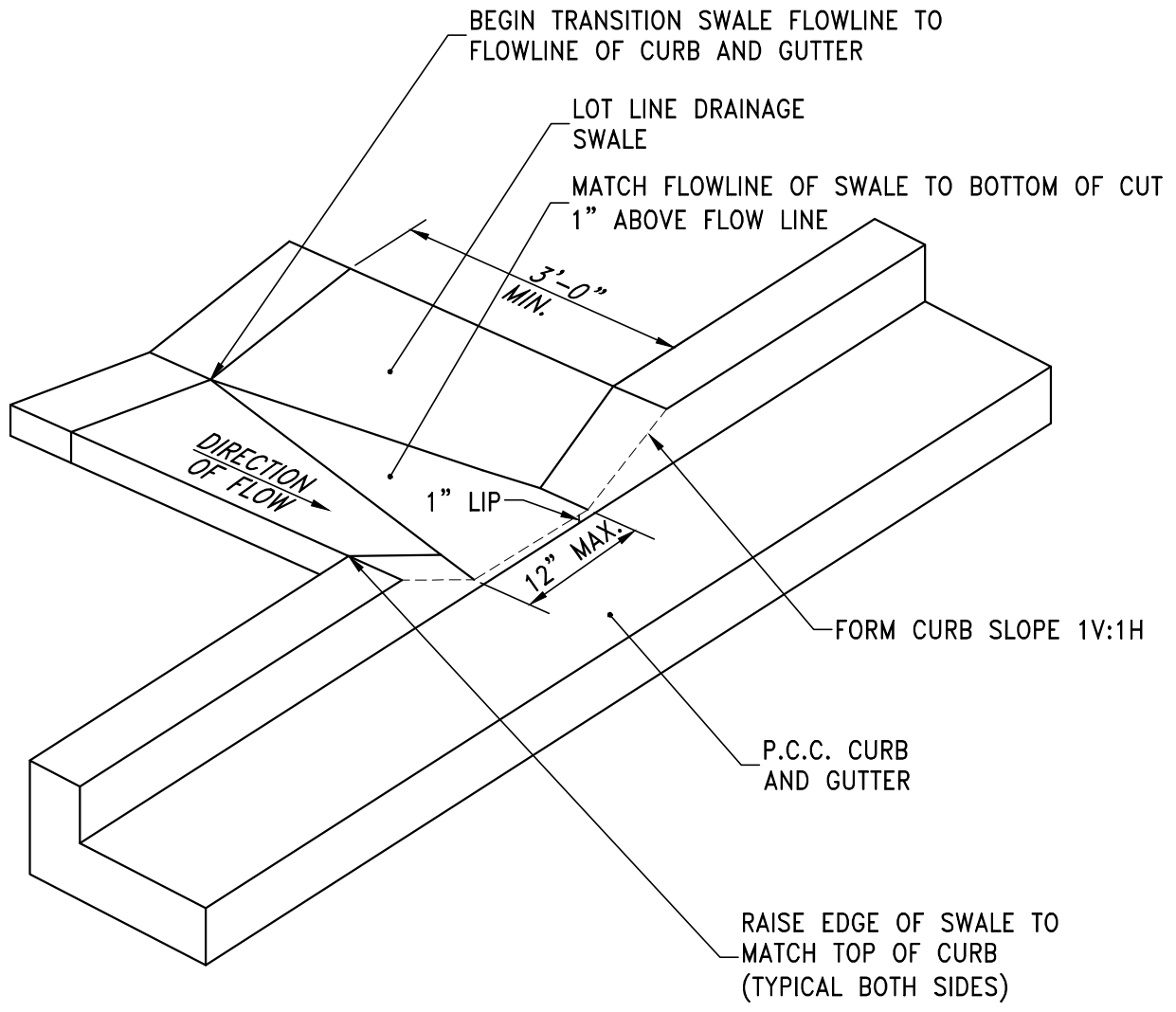

NOTES:

1. P.C.C. CURB AND GUTTER PER R-109.
2. LOT LINE DRAINAGE SWALE PER R-201 OR APPROVED LOW IMPACT DEVELOPMENT FEATURE.
3. CURB OPENING TO BE USED ON LOW SPEED LOCAL ROADWAYS ONLY.
4. CURB OPENING MAY BE REPLACED WITH "EVERGRATE" FLUSH BACK STYLE CURB OPENING OR APPROVED EQUAL. CURB OPENING SHALL BE CONSTRUCTED PER MANUFACTURER'S INSTALLATION GUIDELINES.



STANDARD DETAILS FOR PUBLIC WORKS CONSTRUCTION

DRAWING No.

CURB OPENING

R-112

APPROVED BY: KK DATE: 2/2026

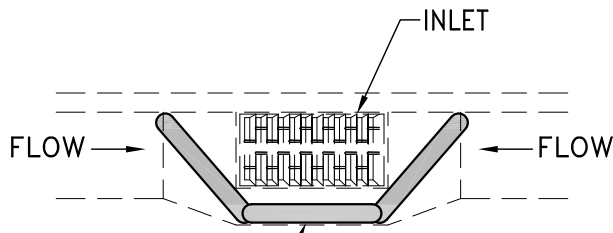

(3) GRAVEL BAGS MIN.
TYPE 4R CATCH BASIN.

TYPE 4R CATCH BASIN

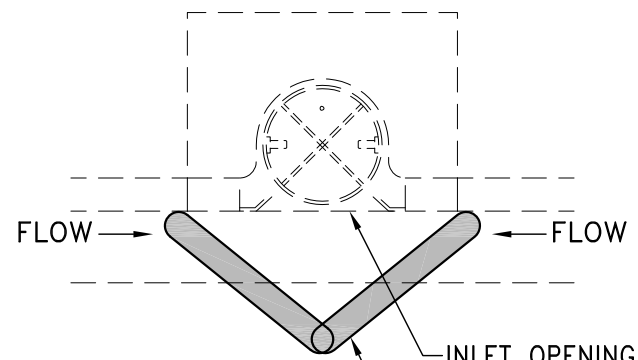

INLET OPENING
(2) GRAVEL BAGS,
MIN. TYPE 1 CATCH
BASIN.

TYPE 1 CATCH BASIN

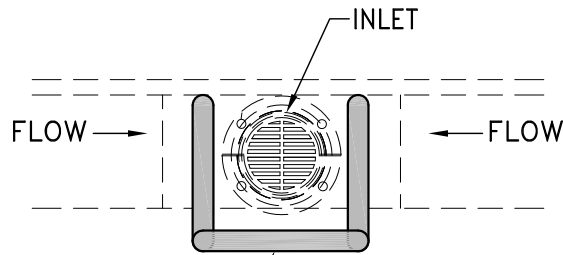

(3) GRAVEL BAGS MIN.
INLET TYPE CATCH
BASIN.

INLET TYPE CATCH BASIN

NOTES:

1. ALL STORM DRAIN INLET PROTECTION SHALL BE IN PLACE PRIOR TO COMMENCING CONSTRUCTION. ALL SITE BMP PLACEMENT AND MAINTENANCE SHALL CONFORM TO THE REQUIREMENTS OF THE CONTRACTOR'S STORM WATER POLLUTION PREVENTION PLAN (SWPPP).
2. THE CONTRACTOR SHALL INSPECT THE SITE DAILY, PRIOR TO FORECASTED WEATHER EVENTS AND WITHIN 24 HOURS OF ANY EVENT THAT CREATES RUNOFF AT THE SITE. DISTURBED OR BROKEN BAGS SHALL BE REPLACED. SEDIMENT AND DEBRIS SHALL BE REMOVED AND DISPOSED.
3. GRAVEL BAGS:
 - 3.1. BAGS SHALL BE WOVEN POLYPROPYLENE, POLYETHYLENE OR POLYAMITE FABRIC, MIN. WEIGHT 4oz/SY, MULLEN BURST STRENGTH EXCEEDING 300 PSI AND ULTRA VIOLET STABILITY EXCEEDING 70%.
 - 3.2. EACH GRAVEL-FILLED BAG SHALL HAVE A MIN. LENGTH OF 30", MIN. WIDTH OF 8" AND MIN. THICKNESS OF 4".
 - 3.3. GRAVEL SHALL BE BETWEEN 1/2" TO 1" IN DIAMETER AND CLEAN AND FREE FROM CLAY BALLS, ORGANIC MATTER AND OTHER DELETERIOUS MATERIALS.
4. AFTER CONSTRUCTION WHEN GRAVEL BAGS ARE REMOVED, ALL CONSTRUCTION MATERIAL, DEBRIS, SEDIMENT, ETC. SHALL BE REMOVED FROM INLET OR CATCH BASIN BY VACUUM TRUCK.



STANDARD DETAILS FOR PUBLIC WORKS CONSTRUCTION

DRAWING No.

**STORM DRAIN INLET
PROTECTION**

R-113

APPROVED BY: JF

DATE: 1/2013

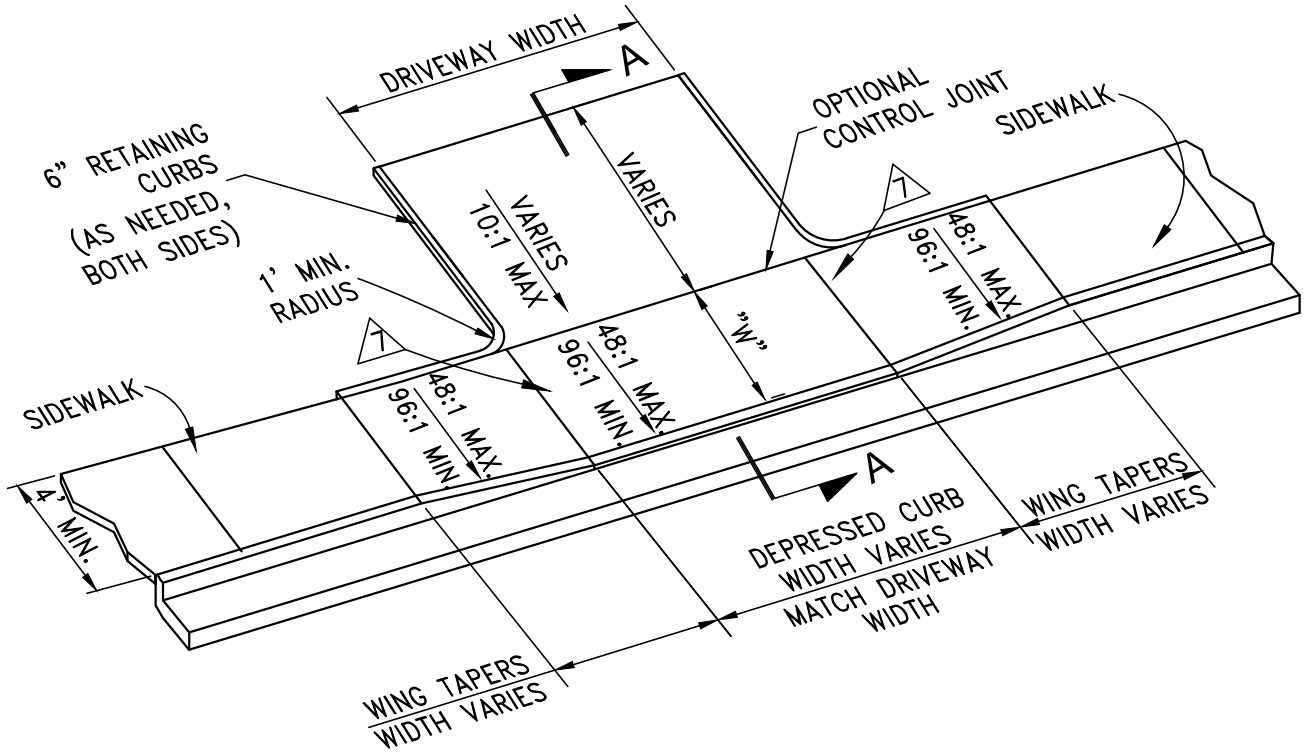

PLAN

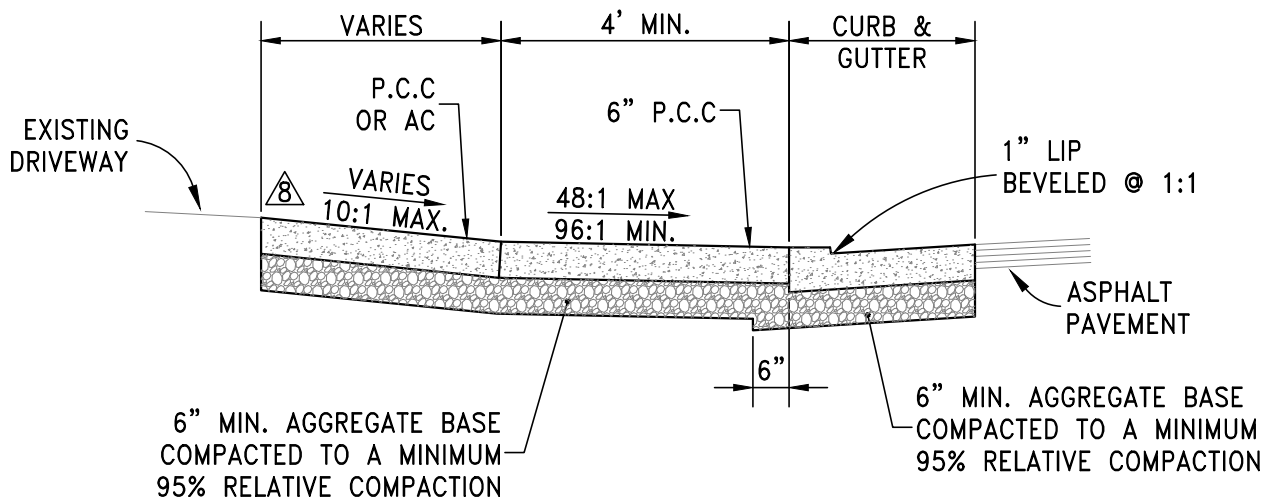

SECTION A-A



STANDARD DETAILS FOR PUBLIC WORKS CONSTRUCTION

DRAWING No.

P.C.C. DRIVEWAY APRON

R-114A

APPROVED BY: KK

DATE: 2/2026

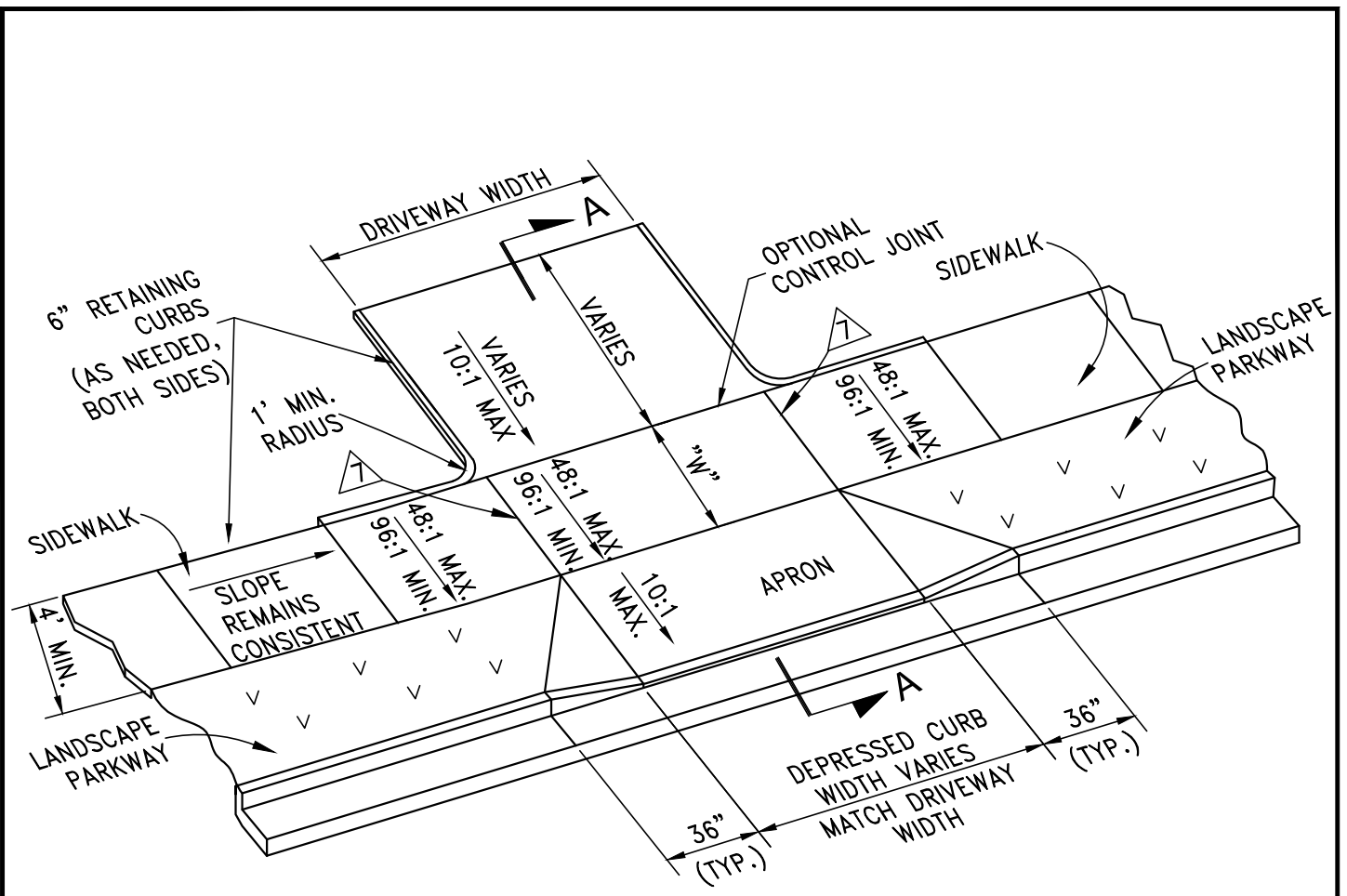

PLAN

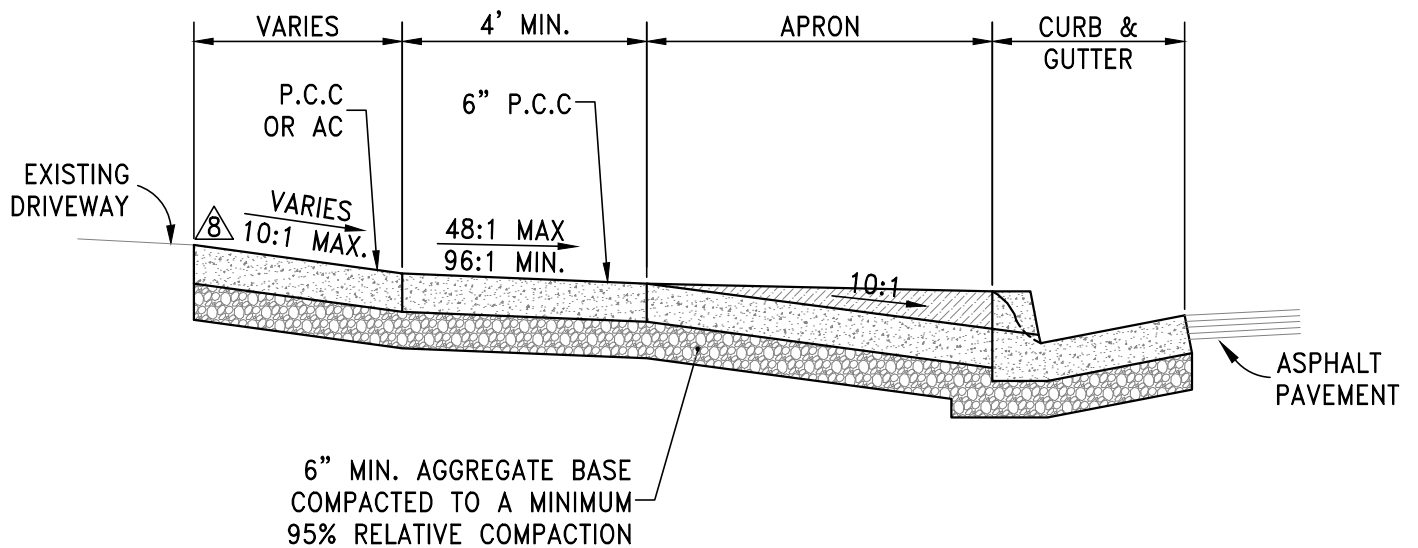

SECTION A-A



STANDARD DETAILS FOR PUBLIC WORKS CONSTRUCTION

DRAWING No.

P.C.C. DRIVEWAY APRON - PARKWAY

R-114B

APPROVED BY: KK

DATE: 2/2026

NOTES:

1. PORTLAND CEMENT CONCRETE (P.C.C.) SHALL BE 4000 PSI MIN. COMPRESSIVE STRENGTH AT 28 DAYS. ALL CEMENT CONCRETE SHALL HAVE A COARSE AGGREGATE GRADATION CONFORMING TO SIZE No. 67. POLYPROPYLENE OR CELLULOSE FIBERS SHALL BE ADDED TO THE P.C.C. AT 1.5 LBS PER CUBIC YARD. MIX DESIGN SHALL CONFORM TO THE REQUIREMENTS OF SECTION 337.10 OF SSPWC. ALL MATERIALS SHALL CONFORM TO SSPWC.
2. AGGREGATE BASE MATERIAL UNDER DRIVEWAYS AND SIDEWALKS SHALL BE TYPE 2, CLASS B CRUSHED AGGREGATE BASE. ALL MATERIALS SHALL CONFORM TO SSPWC SECTION 200.
3. RESIDENTIAL DRIVEWAYS SHALL BE POURED SEPARATE FROM CURB AND GUTTER.
4. COMMERCIAL DRIVEWAYS MAY BE POURED MONOLITHIC WITH CURB AND GUTTER. COMMERCIAL DRIVEWAYS TO HAVE #4 BARS AT 18" ON CENTER LONGITUDINAL & TRANSVERSE EXTENDING INTO GUTTER PAN AND DRIVEWAY WINGS. MINIMUM 2" CONCRETE COVER FOR ALL REINFORCING BARS. WHEN COMMERCIAL DRIVEWAY APPROACH AND CURB & GUTTER IS POURED SEPARATELY, IT SHALL BE REQUIRED FOR EACH REINFORCING BAR TO BE DOWELED INTO ADJACENT CURB & GUTTER. DOWELS SHALL #4 REBAR, PENETRATE INTO CURB & GUTTER MINIMUM OF 6", SPACED AT 18" ON CENTER AND BE SECURELY TIED TO THE DRIVEWAY APPROACH REINFORCING.
5. IF JOINT EXISTS WITHIN 4 FEET OF DRIVEWAY, REMOVE SIDEWALK AND CURB AND GUTTER TO THAT JOINT.
6. ALL ADJACENT CONCRETE REMOVAL SHALL BE TO NEAT SAW CUT LINES AT RIGHT ANGLES. DOWEL INTO EXISTING ADJACENT CONCRETE DRIVEWAY APPROACH OR SIDEWALK WITH (2) No. 4 REINFORCEMENT BARS EQUALLY SPACED ACROSS WIDTH "W". DOWELS SHALL PENETRATE A MINIMUM OF 4" INTO EXISTING CONCRETE.
7. WEAKENED PLANE JOINTS SHALL BE CONSTRUCTED AT 5 FT INTERVALS OR IN ACCORDANCE WITH SECTION 312 OF THE SSPWC.
8. SPECIAL DETAILS AND GRADING SHALL BE PROVIDED WHEN DRIVEWAYS SLOPE DOWN IN LOWER ELEVATION FROM THE FLOW LINE OF THE GUTTER.
9. IN NEW CONSTRUCTION, DRIVEWAYS SHALL NOT SLOPE DOWN FROM FLOW LINE OF THE GUTTER.



STANDARD DETAILS FOR PUBLIC WORKS CONSTRUCTION

DRAWING No.

**NOTES -
P.C.C. DRIVEWAY APRON**

R-114C

APPROVED BY: KK

DATE: 2/2026

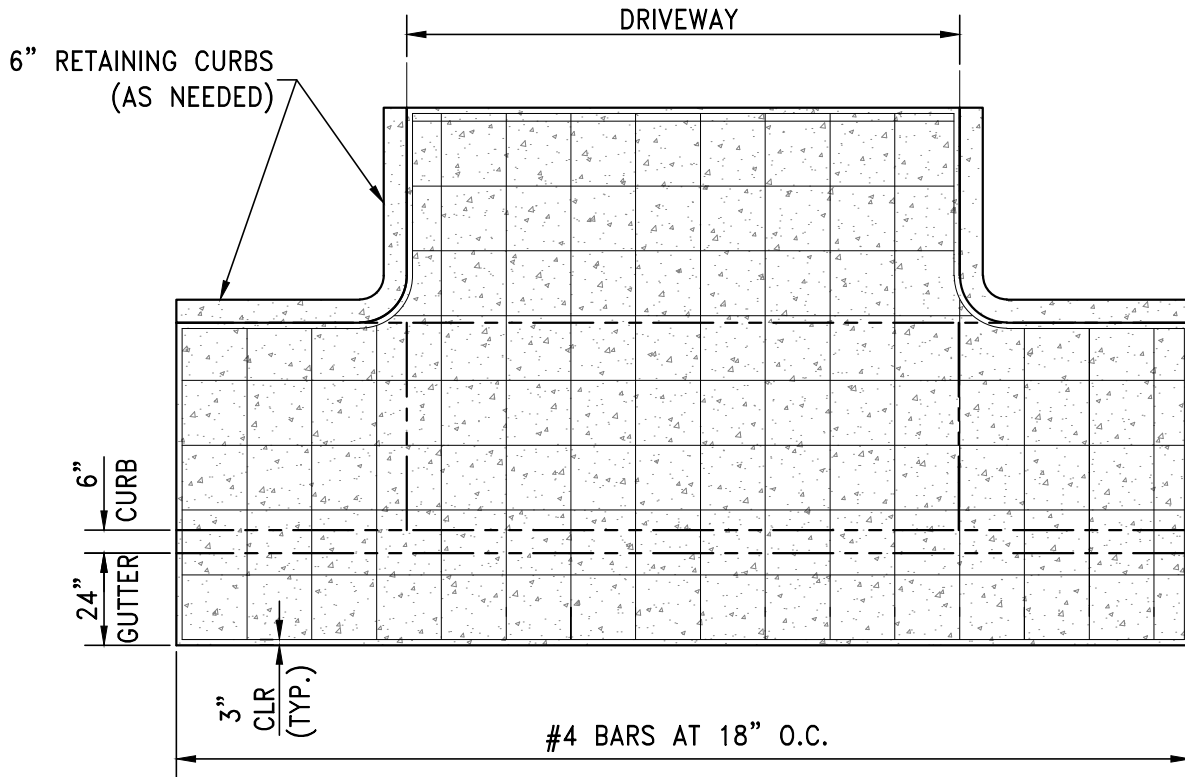

MONOLITHIC POUR

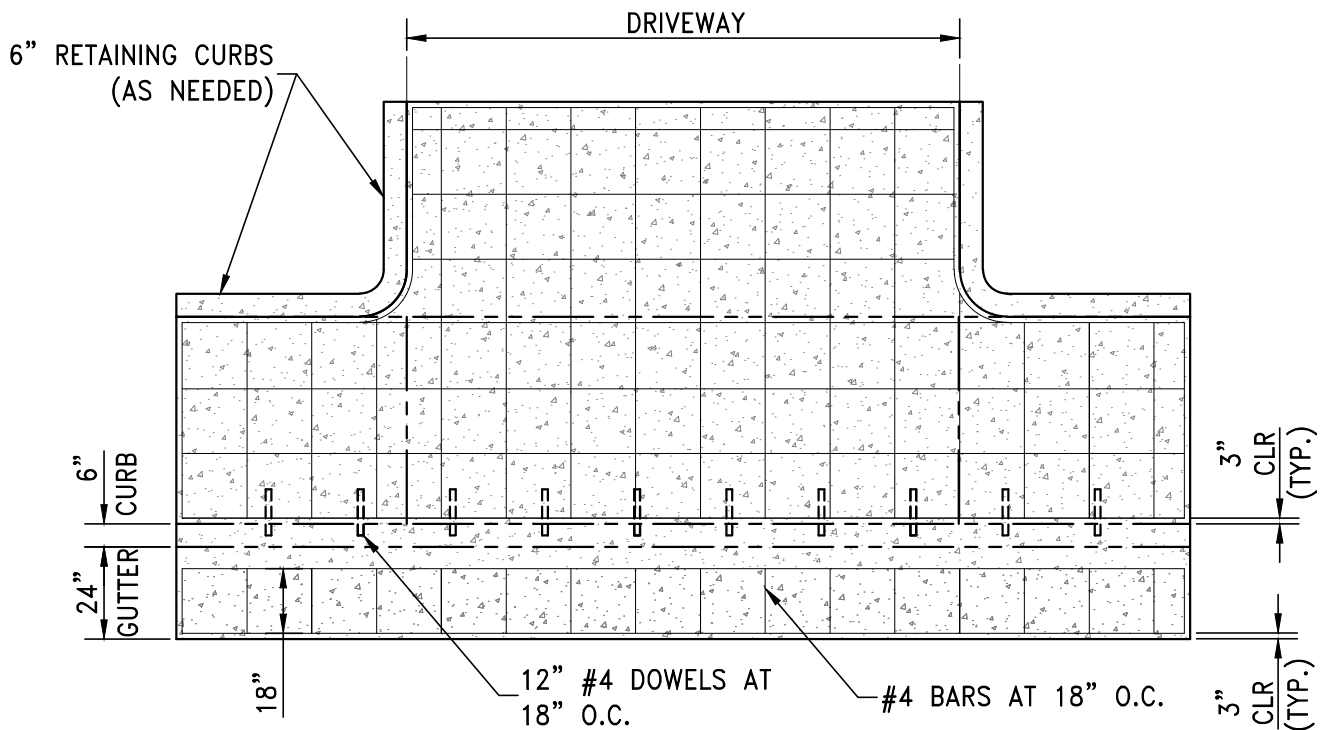

TWO-PART POUR



STANDARD DETAILS FOR PUBLIC WORKS CONSTRUCTION

**P.C.C. DRIVEWAY APRON -
REBAR**

DRAWING No.

R-114D

APPROVED BY: KK

DATE: 2/2026

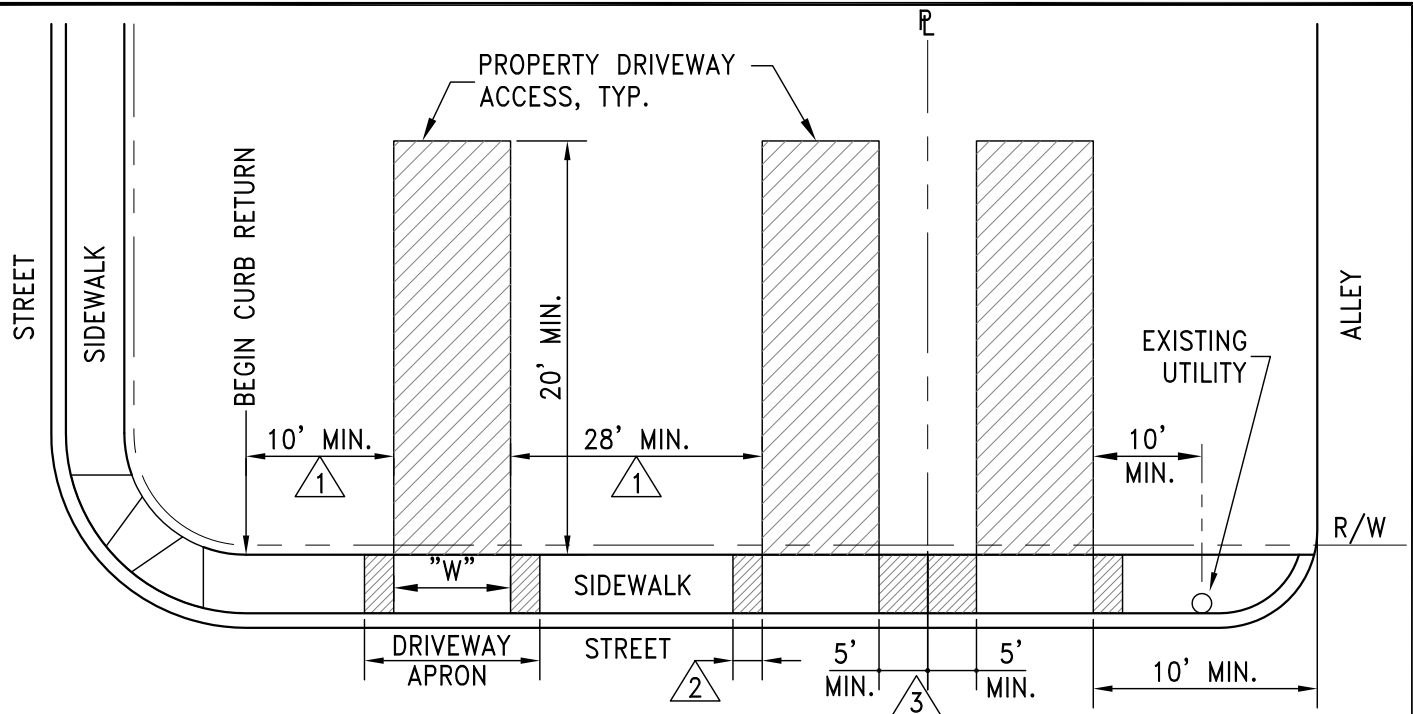

	RESIDENTIAL	MULTI-FAMILY LIGHT COMMERCIAL ^{△4}	HEAVY COMMERCIAL AND INDUSTRIAL ^{△5}
"W" DRIVEWAY OPENING (WIDTH)	12' MIN. 30' MAX. ^{△7}	14' MIN. (ONE-WAY) 24' MIN. (TWO-WAY) 36' MAX.	16' MIN. (ONE-WAY) 30' MIN. (TWO-WAY) 54' MAX. (HEAVY TRUCK)

NOTES:

- ^{△1.} COMMERCIAL COLLECTOR - 50'
MINOR ARTERIAL - 150'
MAJOR ARTERIAL - 235'
DOWNTOWN PARKING DISTRICT TO BE APPROVED BY THE CITY ENGINEER. } REQUIRED DIMENSIONS OUTSIDE THE DOWNTOWN PARKING DISTRICT. VARIANCE REQUIRED WHEN THIS STANDARD CANNOT BE MET.
- ^{△2.} DRIVEWAY WING TAPER LENGTH VARIES. SEE P.C.C. DRIVEWAY APRON DETAIL.
- ^{△3.} 5' MINIMUM SPACE NOT REQUIRED ON SHARED DRIVEWAYS. WHEN THIS DIMENSION BETWEEN ADJACENT DRIVEWAYS IS LESS THAN 10', SUCH AS WITH CUL-DE-SAC CONFIGURATIONS, THE CURB SHALL BE DEPRESSED BETWEEN THE DRIVEWAYS. PROPERTIES WITH COMMON INTERNAL ACCESS MAY SHARE A SINGLE DRIVEWAY WITH THE APPROPRIATE EASEMENT.
- ^{△4.} INCLUDES MULTI-RESIDENTIAL WITH 2 UNITS OR GREATER, OFFICE BUILDINGS, AND OTHER COMMERCIAL BUILDINGS.
- ^{△5.} INCLUDES DRIVE-IN ESTABLISHMENTS, FACTORIES, SERVICE STATIONS, WAREHOUSES AND DISTRIBUTION, MANUFACTURING AND INDUSTRIAL.
- 6. ANY DEVIATION FROM THESE DIMENSIONS MUST BE SUBMITTED TO AND APPROVED BY THE CITY ENGINEER.
- ^{△7.} THE WIDTH OF THE DEPRESSED CURB SECTION OF THE DRIVEWAY IS TO MATCH THE WIDTH OF THE LARGEST GARAGE OPENING OR THE OPENING THAT FACES THE STREET.
- 8. DRIVEWAYS ARE TO CONNECT PERPENDICULAR TO THE STREET CENTERLINE. ON CUL-DE-SACS, CURVED STREETS, ETC., WHERE THIS REQUIREMENT MAY NOT BE POSSIBLE, ANY DIFFERENT DRIVEWAY SHALL BE TREATED AS AN INTERSECTION AND ACCESS MANAGEMENT STANDARDS SHALL APPLY.
- 9. ADDITIONAL DRIVEWAY WIDTH MAY BE ALLOWED TO THE PROPERTY LINE SIDE OF THE NORMAL DRIVEWAY LOCATION TO ACCOMMODATE LARGE VEHICLE ACCESS, ACCESS TO THE REAR OR SIDE YARD, ETC., BUT ONLY AS APPROVED BY THE CITY ENGINEER.



STANDARD DETAILS FOR PUBLIC WORKS CONSTRUCTION

DRAWING No.

DRIVEWAY GEOMETRICS

R-115A

APPROVED BY: JF

DATE: 11/2016

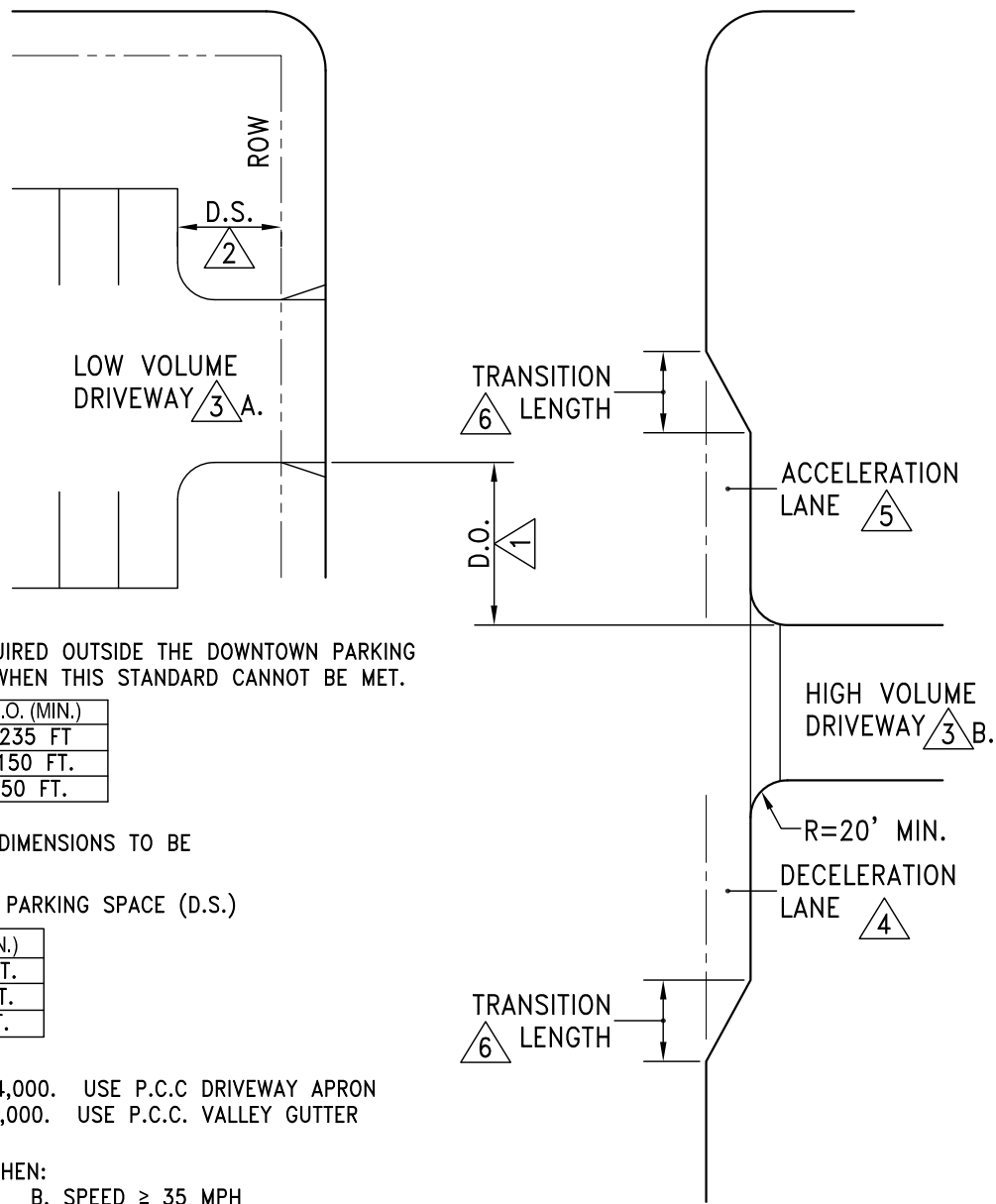

NOTES:

1. DRIVEWAY OFFSET (D.O.) – REQUIRED OUTSIDE THE DOWNTOWN PARKING DISTRICT. VARIANCE REQUIRED WHEN THIS STANDARD CANNOT BE MET.

FACILITY TYPES	D.O. (MIN.)
MAJOR ARTERIALS	235 FT.
MINOR ARTERIALS	150 FT.
COMMERCIAL COLLECTORS	50 FT.

NOTE:
DOWNTOWN PARKING DISTRICT, DIMENSIONS TO BE APPROVED BY CITY ENGINEER

2. DISTANCE FROM ROW TO FIRST PARKING SPACE (D.S.)

PROJECT ADT	D.S. (MIN.)
< 1000	25 FT.
1,000 – 10,000	50 FT.
> 10,000	100 FT.

3. DRIVEWAY TYPE:
 A. PROJECT ADT < 4,000. USE P.C.C DRIVEWAY APRON
 B. PROJECT ADT ≥ 4,000. USE P.C.C. VALLEY GUTTER

4. DECELERATION LANE REQUIRED WHEN:
 A. STREET ADT > 10,000 B. SPEED ≥ 35 MPH
 C. DRIVEWAY ADT > 1,000 D. PEAK HOUR RIGHT TURN INGRESS ≥ 40
 E. FRONTAGE > 150' F. WILL NOT RESTRICT UPSTREAM PROPERTIES

5. ACCELERATION LANE REQUIRED WHEN:
 A. STREET ADT > 10,000
 B. SPEED ≥ 45 MPH
 C. PEAK HOUR DRIVEWAY RIGHT TURN EGRESS ≥ 75
 D. FRONTAGE LONG ENOUGH TO ACCOMMODATE FULL ACCELERATION AND MERGE LENGTH

6. TRANSITION LENGTH:
 L=TRANSITION LENGTH
 W= OFFSET
 S= DESIGN SPEED
 S ≥ 45 MPH
 $L = WS$
 S ≤ 40 MPH
 $L = WS^2/60$

7. ANY DEVIATION FROM THESE STANDARDS INCLUDING NDOT AND RTC MUST BE SUBMITTED TO AND APPROVED BY THE CITY ENGINEER.
 8. IF PROPERTIES ARE SHARING COMMON INTERNAL ACCESS, THEN DRIVEWAY SHALL BE TREATED AS A SINGLE DRIVEWAY WITH RECIPROCAL ACCESS EASEMENTS.



STANDARD DETAILS FOR PUBLIC WORKS CONSTRUCTION

DRAWING No.

DRIVEWAY GEOMETRICS

R-115B

APPROVED BY: JF DATE: 1/2013

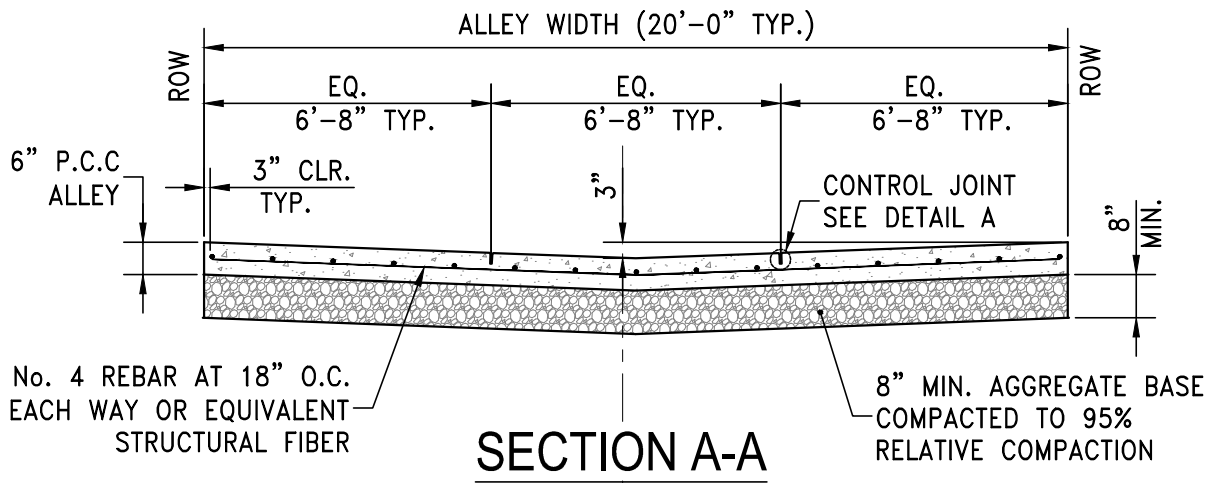

SECTION A-A

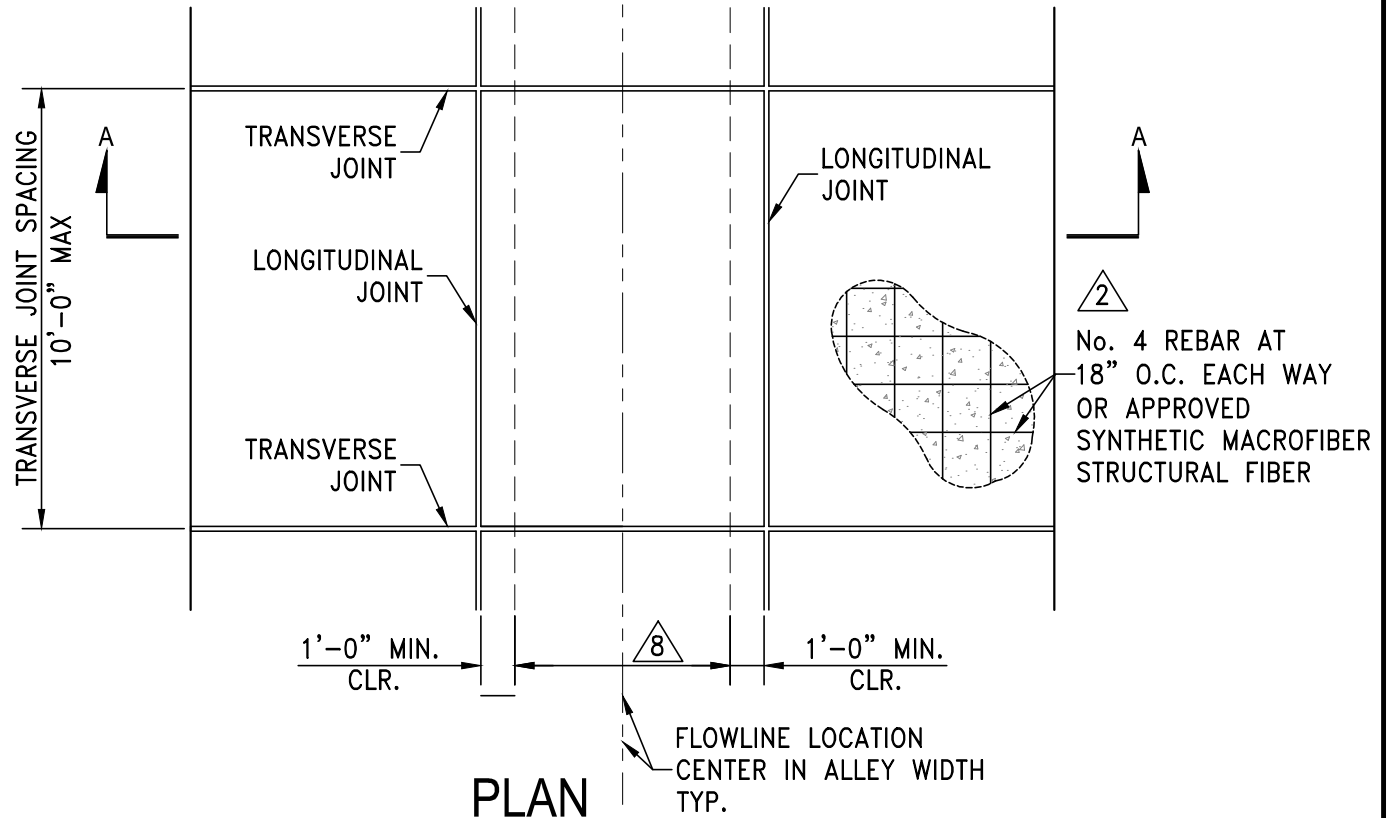

PLAN

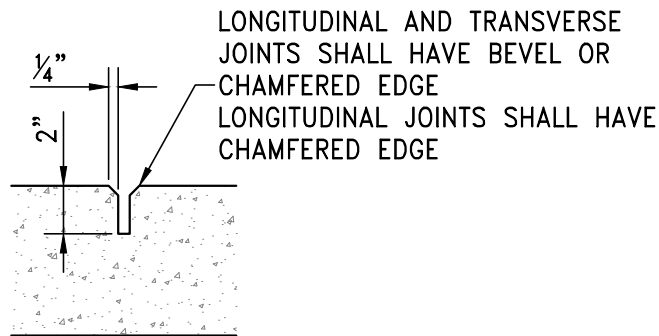

DETAIL A (CONTROL JOINT)

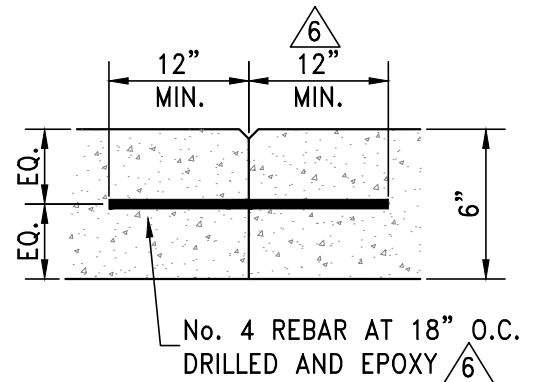

DETAIL B (CONSTRUCTION JOINT)



STANDARD DETAILS FOR PUBLIC WORKS CONSTRUCTION

DRAWING No.

P.C.C. ALLEY

R-116A

APPROVED BY:KK

DATE: 2/2026

NOTES:

1. PORTLAND CEMENT CONCRETE (P.C.C.) SHALL BE 4000 PSI MIN. COMPRESSIVE STRENGTH AT 28 DAYS. ALL CEMENT CONCRETE SHALL HAVE A COARSE AGGREGATE GRADATION CONFORMING TO SIZE No. 67. POLYPROPYLENE OR CELLULOSE FIBERS SHALL BE ADDED TO THE P.C.C. AT 1.5 LBS PER CUBIC YARD. MIX DESIGN SHALL CONFORM TO THE REQUIREMENTS OF SECTION 337.10 OF SSPWC. ALL MATERIALS SHALL CONFORM TO SSPWC.
2. THE SYNTHETIC MACROFIBER SHALL BE "TUF-STRAND SF" OR APPROVED EQUAL. MINIMUM FIBER DOSAGE SHALL BE 5.0 LBS./CUBIC YARD.
3. AGGREGATE BASE MATERIAL UNDER PCC ALLEY WAY SHALL BE TYPE 2, CLASS B CRUSHED AGGREGATE BASE. MATERIALS SHALL CONFORM TO SSPWC SECTION 200.
4. ALL ADJACENT CONCRETE REMOVAL SHALL BE TO NEAT SAW CUT LINES AT RIGHT ANGLES TO NEW CONCRETE.
5. ADJUSTMENT OF UTILITIES AND SURVEY MONUMENTS SHALL BE FLUSH WITH SLAB. UTILITIES SHALL BE A MINIMUM OF ONE FOOT AWAY FROM FLOW LINE.
6. NO. 4 REBAR DOWELS SHALL BE DRILLED AND EPOXIED INTO ADJACENT SLAB. DOWELS SHALL BE CENTERED IN THE P.C.C. SECTION AND EMBEDDED 12" INTO THE SLAB.
7. JOINTS TO BE CUT AT A MINIMUM OF 4 HOURS TO A MAXIMUM OF 12 HOURS AFTER THE CONCLUSION OF BRUSH FINISHING.
8. FLOW LINE SHALL BE CENTERED WHERE POSSIBLE, BUT MAY BE OFFSET TO IMPROVE DRAINAGE. FLOWLINE MUST REMAIN A MINIMUM 1 FOOT CLEAR FROM LONGITUDINAL JOINTS AND 1 FOOT MINIMUM CLEAR FROM EDGE OF UTILITIES.
9. INSTALL 1/2" THICK ASPHALT FIBER EXPANSION BOARD WHERE ALLEY ABUTS BUILDINGS OR STRUCTURES.
10. FULLY WRAP POLES WITH MINIMUM 1/2" FLEXIBLE EXPANSION JOINT.
11. CONCRETE REMOVAL SHALL BE TO AN EXISTING JOINT. PANELS SHALL BE FULL DEPTH SAWCUT TO PROVIDE A CLEAN EDGE PRIOR TO REPLACING P.C.C. ALLEY.



STANDARD DETAILS FOR PUBLIC WORKS CONSTRUCTION

DRAWING No.

NOTES - P.C.C. ALLEY

R-116B

APPROVED BY: KK | DATE: 2/2026

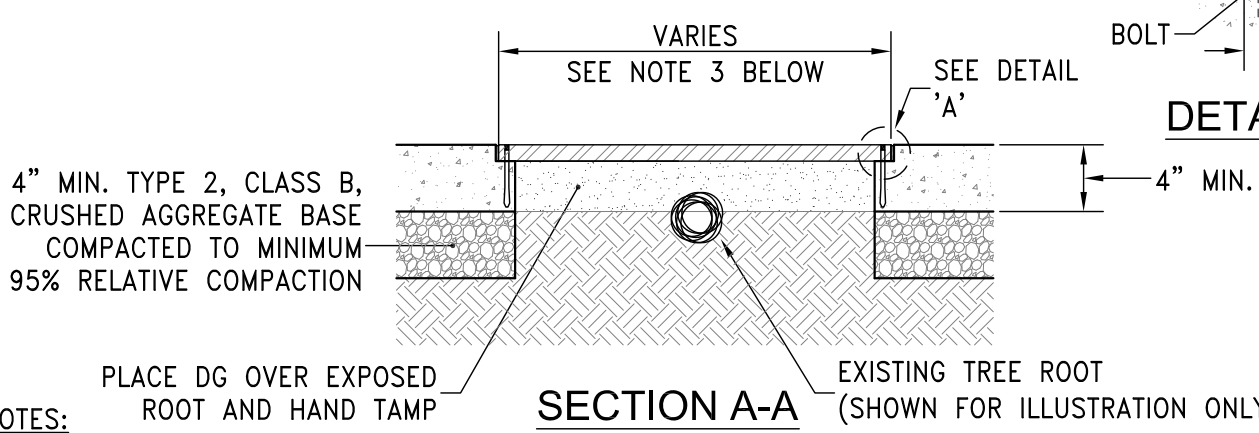
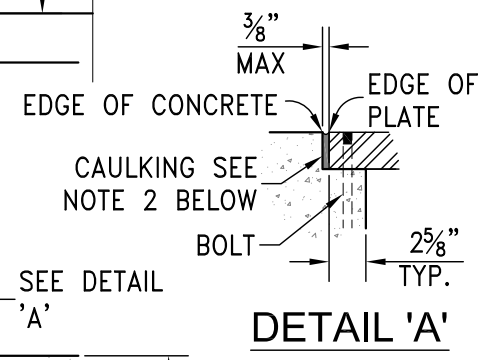
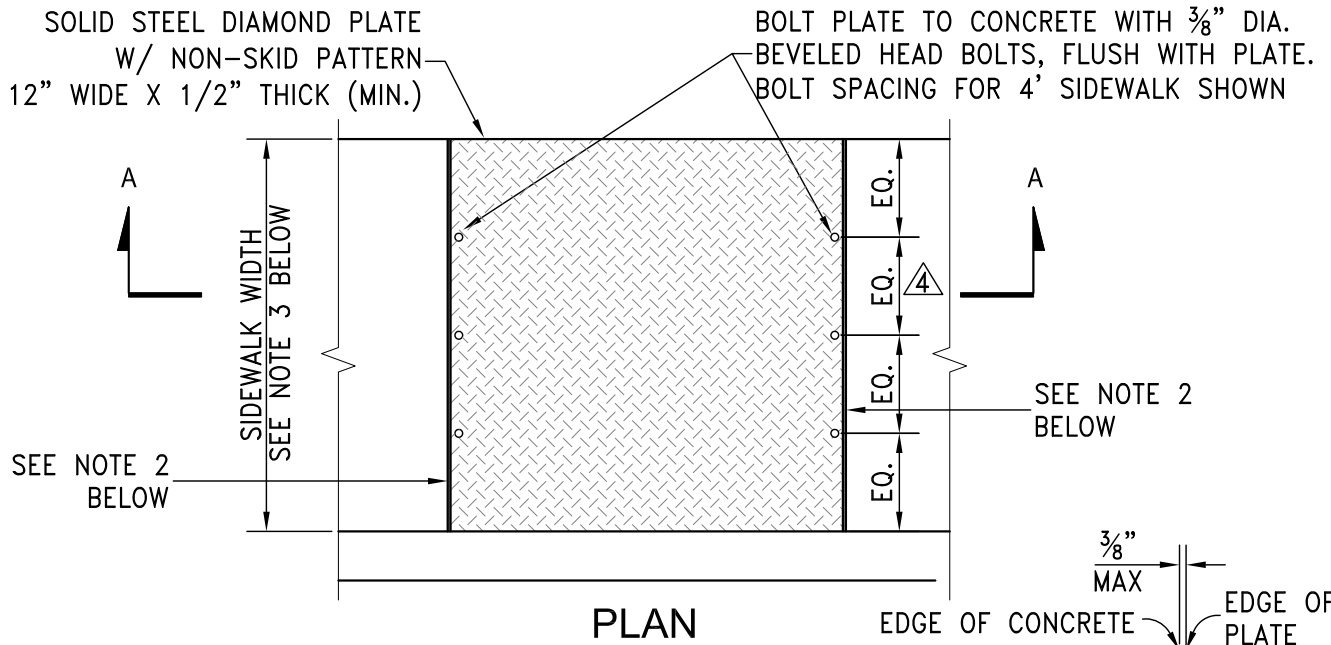

NOTES:
PLACE DG OVER EXPOSED ROOT AND HAND TAMP

1. CONTRACTOR SHALL REMOVE ONLY THE EXISTING CONCRETE WITHIN THE ROOT MITIGATION LIMITS. THE CONTRACTOR SHALL EMPLOY AN ISA CERTIFIED ARBORIST TO PERFORM ROOT CROWN EXCAVATION / ROOT PRUNING. ISA CERTIFIED ARBORIST SHALL COORDINATE THIS WORK WITH THE CITY OF RENO URBAN FORESTER (334-2270).
2. SET PLATE FLUSH WITH ADJACENT CONCRETE AND PROVIDE $\frac{3}{8}$ " MAX GAP BETWEEN STEEL PLATE AND EDGE OF SIDEWALK. FILL GAP WITH CAULKING AFTER PLACEMENT OF PLATE. CAULKING MATERIAL SHALL BE GE SILICONE II* W/D SUPREME, OR APPROVED EQUAL. COLOR SHALL BE WHITE.
3. ROOT PLATE WIDTH SHALL MATCH WIDTH OF SIDEWALK. ROOT PLATE LENGTH VARIES, FINAL LENGTH SHALL BE DETERMINED IN THE FIELD BY THE CERTIFIED ARBORIST AND ENGINEER.
4. BOLTS: $\frac{3}{8}$ " DIA x $2 \frac{7}{8}$ " LONG DYNABOLT SLEEVE ANCHOR RAMSET REDHEAD FS-3826 OR APPROVED EQUAL. SIDEWALK WIDER THAN 4FT, BOLTS SHALL BE PLACED AT 18" O.C. FOR WIDTH OF SIDEWALK.
5. CONTRACTOR SHALL PROTECT TREES AT ALL TIMES, INCLUDING BUT NOT LIMITED TO TRUNKS, LIMBS AND ROOTS. CONTRACTOR SHALL BE RESPONSIBLE FOR ALL COSTS ASSOCIATED WITH REPAIR OR REMOVAL OF DAMAGED TREES DUE TO CONSTRUCTION ACTIVITIES.



STANDARD DETAILS FOR PUBLIC WORKS CONSTRUCTION

DRAWING No.

SIDEWALK PLATE FOR TREE ROOT CLEARANCE

R-117

APPROVED BY: JF DATE: 1/2013

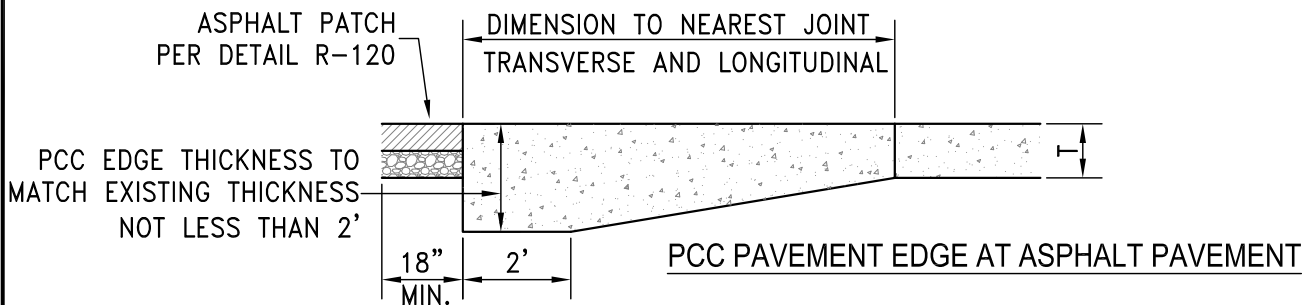
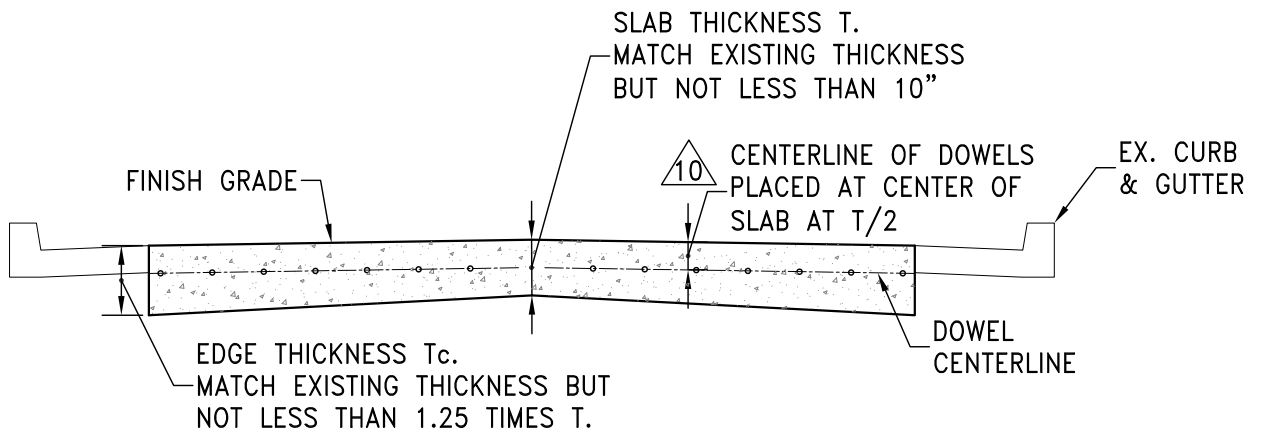
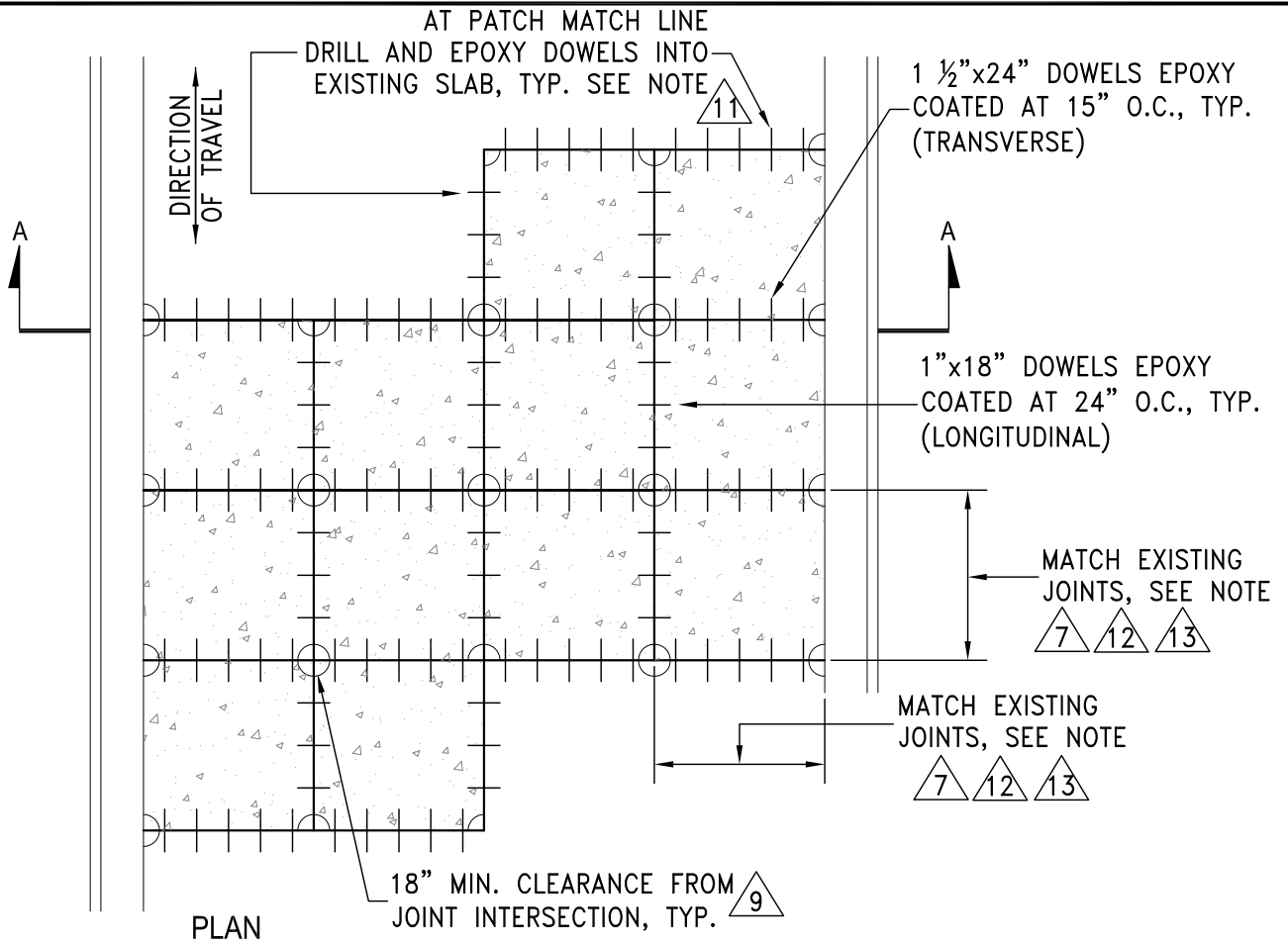

STANDARD DETAILS FOR PUBLIC WORKS CONSTRUCTION

DRAWING No.

CONCRETE PAVEMENT PATCH

R-119A

APPROVED BY: JF

DATE: 8/2014

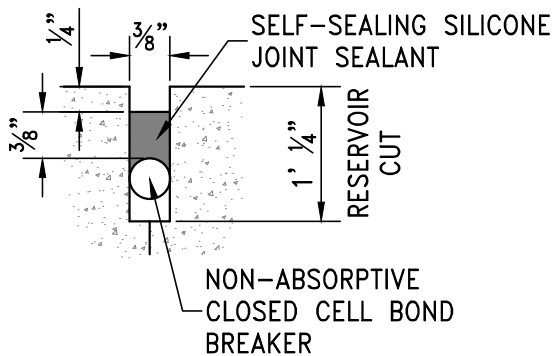
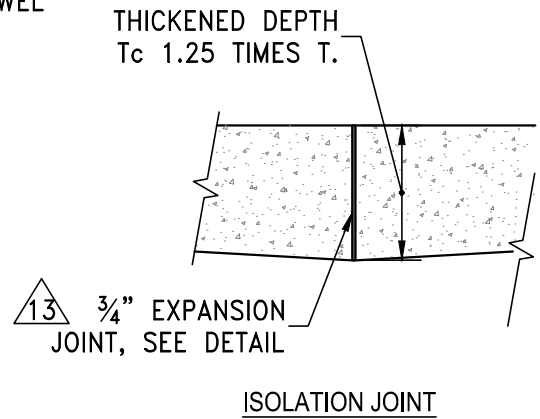
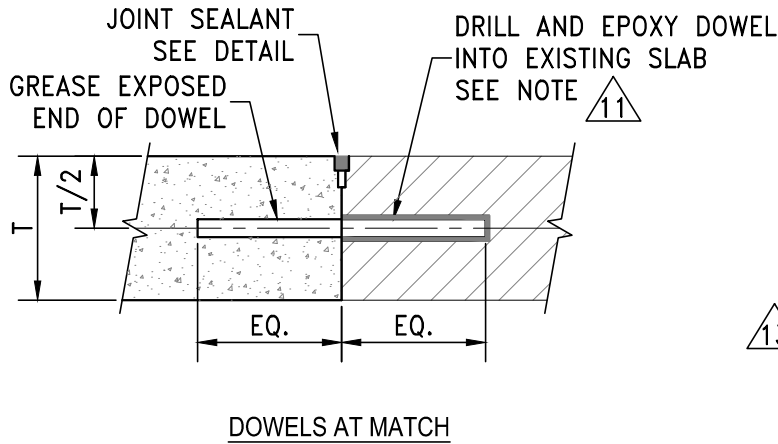
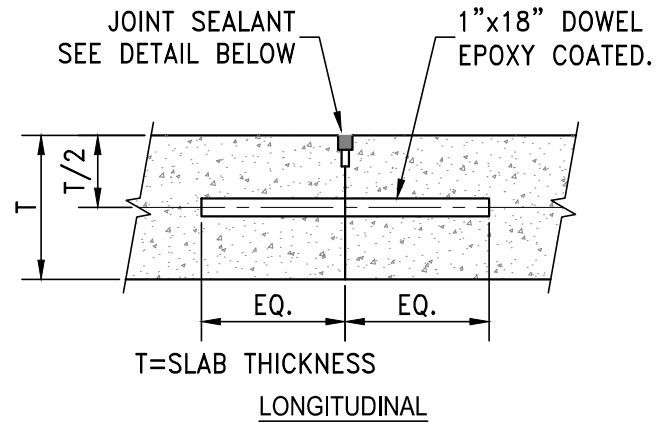
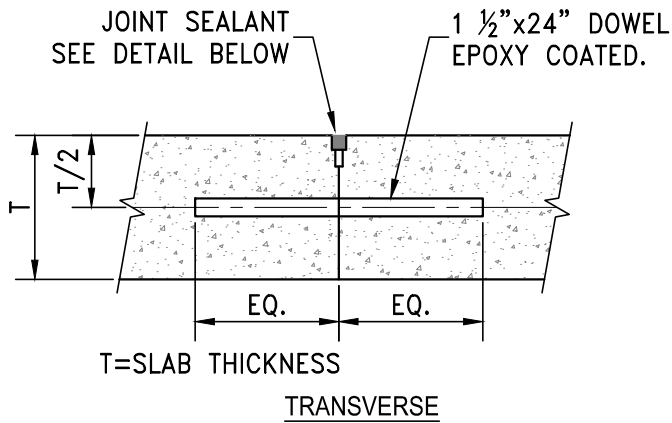

TRANSVERSE CONSTRUCTION JOINT - SINGLE CUT

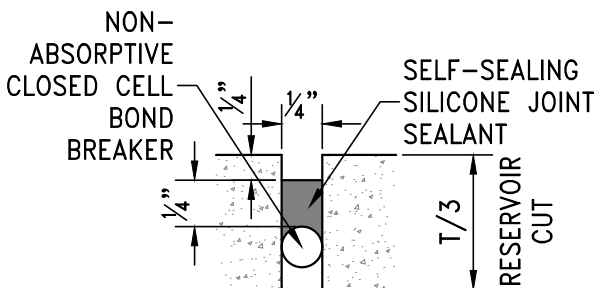

LONGITUDINAL WEAKENED PLANE - SINGLE CUT

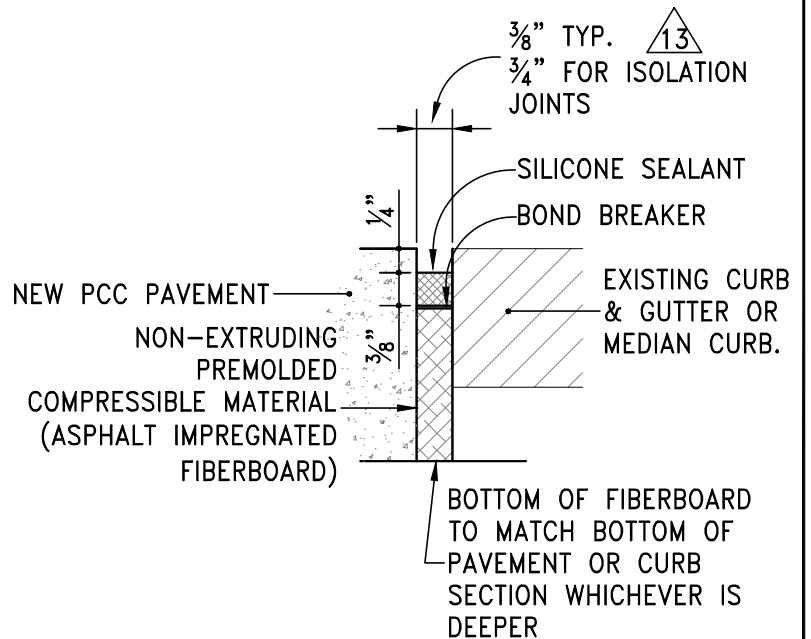

EXPANSION JOINT



STANDARD DETAILS FOR PUBLIC WORKS CONSTRUCTION

**DETAILS - CONCRETE
PAVEMENT PATCH**

DRAWING No.

R-119B

APPROVED BY: KK

DATE: 2/2026

NOTES:

1. A PERMIT MUST BE OBTAINED FROM THE CITY ENGINEER PRIOR TO CUTTING ANY PUBLIC RIGHT-OF-WAY. 24 HOURS PRIOR TO TRENCH EXCAVATION, THE PERMITTEE MUST NOTIFY THE CITY EXCAVATION PERMIT INSPECTOR OR APPLICABLE ENGINEER OF RECORD.
2. ALL MATERIALS AND INSTALLATION PROCEDURES SHALL BE IN ACCORDANCE WITH STANDARD SPECIFICATIONS FOR PUBLIC WORKS CONSTRUCTION, LATEST REVISION. SEE DETAIL R-122 FOR TRENCH EXCAVATION AND BACKFILL REQUIREMENTS.
3. NO CONCRETE SHALL BE PLACED UNTIL FORMS AND SUBGRADE ARE INSPECTED BY THE CITY EXCAVATION PERMIT INSPECTOR OR APPLICABLE ENGINEER OF RECORD.
4. PORTLAND CEMENT CONCRETE (P.C.C.) SHALL HAVE THE FOLLOWING CHARACTERISTICS: 550 PSI MIN. FLEXURAL STRENGTH PRIOR TO OPENING TO TRAFFIC, MAXIMUM WATER/CEMENT RATIO OF 0.45, AIR ENTRAINMENT OF 5.5% \pm 1.5%, SLUMP AT 2 INCHES MAX. UNPLASTICIZED. ALL MATERIALS SHALL CONFORM TO SSPWC.
5. CONCRETE REMOVAL SHALL BE TO AN EXISTING JOINT. PANELS SHALL BE FULL DEPTH SAWCUT TO PROVIDE A CLEAN EDGE PRIOR TO PLACING P.C.C. PAVEMENT PATCH.
6. TUNNELING UNDER CURB, GUTTER OR SIDEWALK IS NOT PERMITTED. COMPLETE REMOVAL IS REQUIRED TO THE NEAREST CONSTRUCTION OR EXPANSION JOINT OUTSIDE THE TRENCH WIDTH, UNLESS OTHERWISE APPROVED BY THE CITY ENGINEER.
- \triangle 7. JOINT SPACING SHALL MATCH EXISTING JOINT SPACING, EXCEPT THAT MAXIMUM SPACING SHALL NOT BE MORE THAN 15' IN ANY DIRECTION, UNLESS APPROVED BY THE CITY ENGINEER.
8. CONTRACTOR SHALL BE RESPONSIBLE FOR PLACEMENT OF LOOP DETECTORS, ADJUSTMENT OF UTILITIES AND SURVEY MONUMENTS TO GRADE AND INSTALLATION OF PAVEMENT MARKINGS.
- \triangle 9. DOWEL BARS SHALL NOT BE PLACED WITHIN 18" OF OPPOSING JOINT.
- \triangle 10. THE ALIGNMENT AND ELEVATION OF DOWELS IS EXTREMELY IMPORTANT. DOWELS SHALL BE CENTERED IN THE P.C.C. SECTION AND SHALL BE PLACED PARALLEL TO THE TOP OF THE PAVEMENT SURFACE WITHIN A TOLERANCE OF \pm 1/16" IN ONE FOOT.
- \triangle 11. DOWEL BARS SHALL BE DRILLED AND EPOXIED INTO ADJACENT SLAB. EXPOSED END OF DOWEL SHALL BE GREASED PRIOR TO POURING P.C.C. PAVEMENT. THE LENGTH OF THE DOWELS TO BE EMBEDDED INTO THE SLAB SHALL BE HALF THE TOTAL LENGTH OF DOWEL BARS.
- \triangle 12. P.C.C. PAVEMENT SLABS WITH A LENGTH TO WIDTH RATIO GREATER THAN 1.25:1 SHALL BE REINFORCED WITH 6"X6" W2XW2 WELDED WIRE FABRIC OR NO. 3 BARS SPACED AT 12" O.C. EACH WAY.
- \triangle 13. 3/8" EXPANSION JOINT MATERIAL SHALL BE PLACED ADJACENT TO CURB AND GUTTER SECTIONS. 3/4" EXPANSION JOINT MATERIAL SHALL BE PLACED ADJACENT TO UTILITIES AND OTHER ISOLATION JOINTS.
14. INITIAL JOINTS CUT SHALL BE PERFORMED WITHIN 24 HOURS OF CONCRETE PLACEMENT. JOINTS SHALL BE CLEANED OUT WITH COMPRESSED AIR PRIOR TO PLACEMENT OF SEAL AND BACKER ROD. SEALANT SHALL BE EUCLID CHEMICAL EUCOLASTIC 1SL OR APPROVED EQUAL, INSTALLED PER MANUFACTURERS RECOMMENDATIONS.
15. P.C.C. PAVEMENT AND CURB AND GUTTER SHALL NOT BE MONOLITHIC.
16. ASPHALT BASED HOT POUR SEALANTS SHALL NOT BE USED, UNLESS OTHERWISE APPROVED BY THE CITY ENGINEER.



STANDARD DETAILS FOR PUBLIC WORKS CONSTRUCTION

DRAWING No.

NOTES - CONCRETE PAVEMENT PATCH

R-119C

APPROVED BY: KK DATE: 2/2026

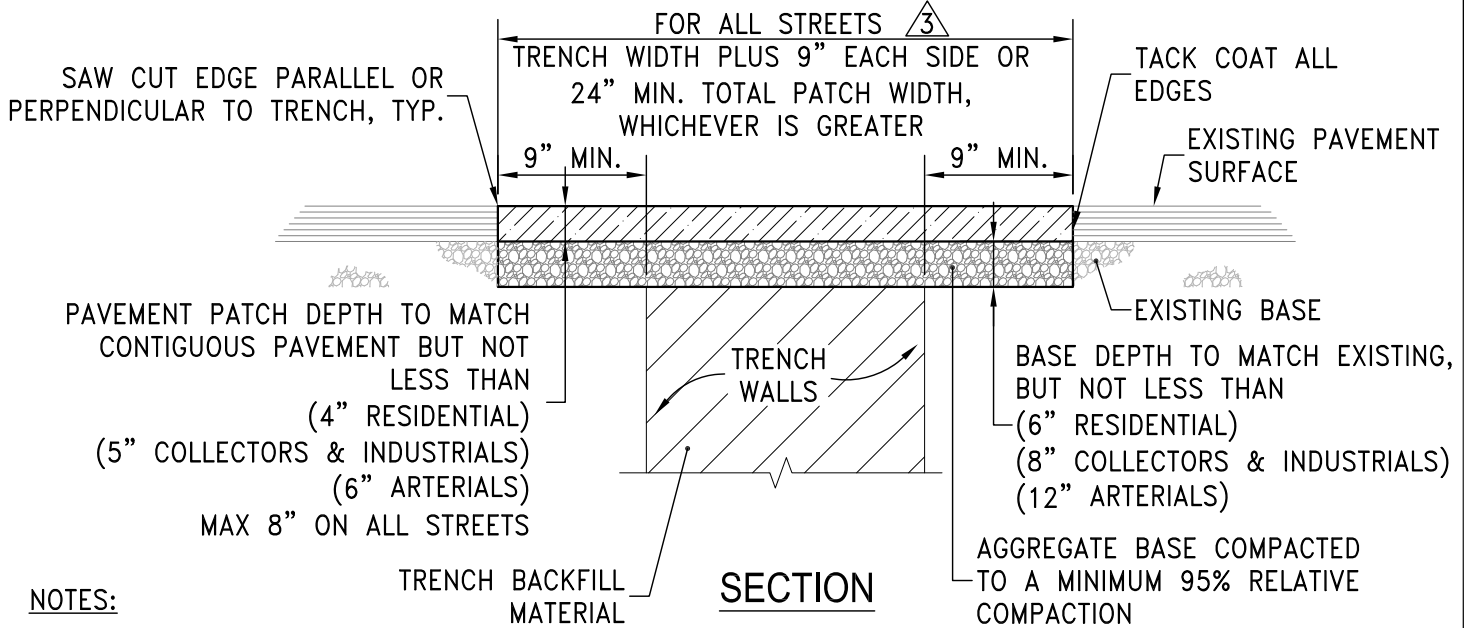

NOTES:

1. AN EXCAVATION/ENCROACHMENT PERMIT MUST BE OBTAINED FROM CITY OF RENO PRIOR TO CUTTING ANY PUBLIC RIGHT-OF-WAY.
2. IF SAW CUT IS WITHIN 2 FEET OF AN EXISTING PAVEMENT EDGE OR EXISTING PAVEMENT PATCH, REMOVE EXISTING PAVEMENT TO THAT EDGE AND REPLACE ENTIRE SECTION.
3. ALL PERMANENT PATCH REPLACEMENT REQUIREMENTS ARE MINIMUM WIDTHS ONLY AND INCLUDES ALL AREAS WHERE THE ASPHALT PAVEMENT HAS BEEN UNDERMINED. THE CITY ENGINEER MAY REQUIRE WIDER PATCH SECTIONS OR OTHERWISE ALTER THESE REQUIREMENTS.
4. AGGREGATE BASE MATERIAL UNDER BITUMINOUS PAVEMENT PATCH SHALL BE TYPE 2, CLASS B CRUSHED AGGREGATE BASE. MATERIALS SHALL CONFORM TO SSPWC SECTION 200.
5. CONTRACTOR SHALL BE RESPONSIBLE FOR REPLACEMENT OF LOOP DETECTORS, ADJUSTMENT OF UTILITIES AND SURVEY MONUMENTS TO GRADE AND INSTALLATION OF PERMANENT PAVEMENT MARKINGS.
6. FOR P.C.C. CURB REPLACEMENT, SAW CUT EXISTING PAVEMENT 18 INCHES MIN. FROM GUTTER LIP LINE, REMOVE AND REPLACE PAVEMENT TO SAW CUT EDGES. CONCRETE MAY BE POURED NEAT AGAINST EXISTING EDGE OF ASPHALT IF APPROVED BY CITY ENGINEER.

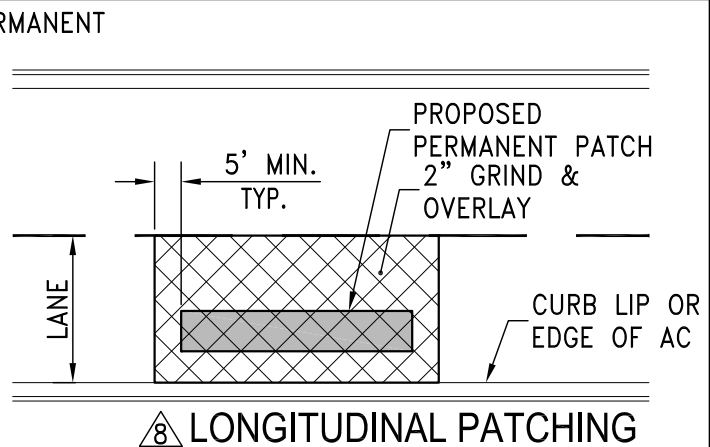
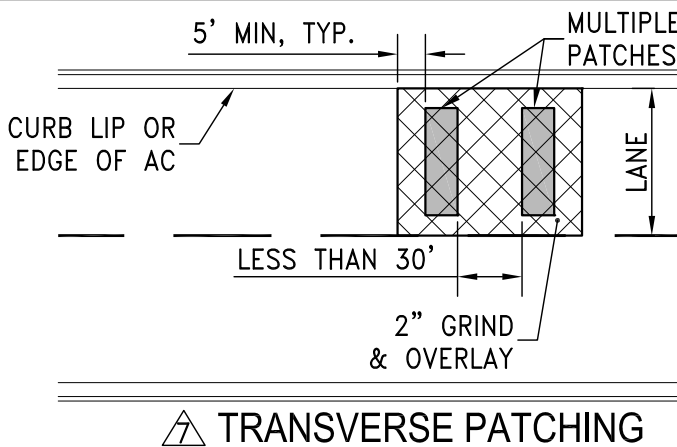

ALL STREETS WITH PAVEMENT CONDITION INDEX (PCI) GREATER THAN 65:

7. TRANSVERSE PATCHES SHALL INCLUDE A 2" GRIND AND OVERLAY WHEREVER THERE ARE MULTIPLE PATCHES WITHIN 30 FEET OF EACH OTHER.
8. LONGITUDINAL PATCHES SHALL INCLUDE 2" GRIND AND OVERLAY TO THE LANE LINES (BIKE, PARKING, OR TRAVEL).

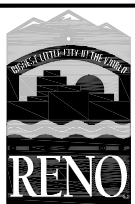

STANDARD DETAILS FOR PUBLIC WORKS CONSTRUCTION

DRAWING No.

PERMANENT BITUMINOUS PAVEMENT PATCH

R-120

APPROVED BY: JF DATE: 1/2013

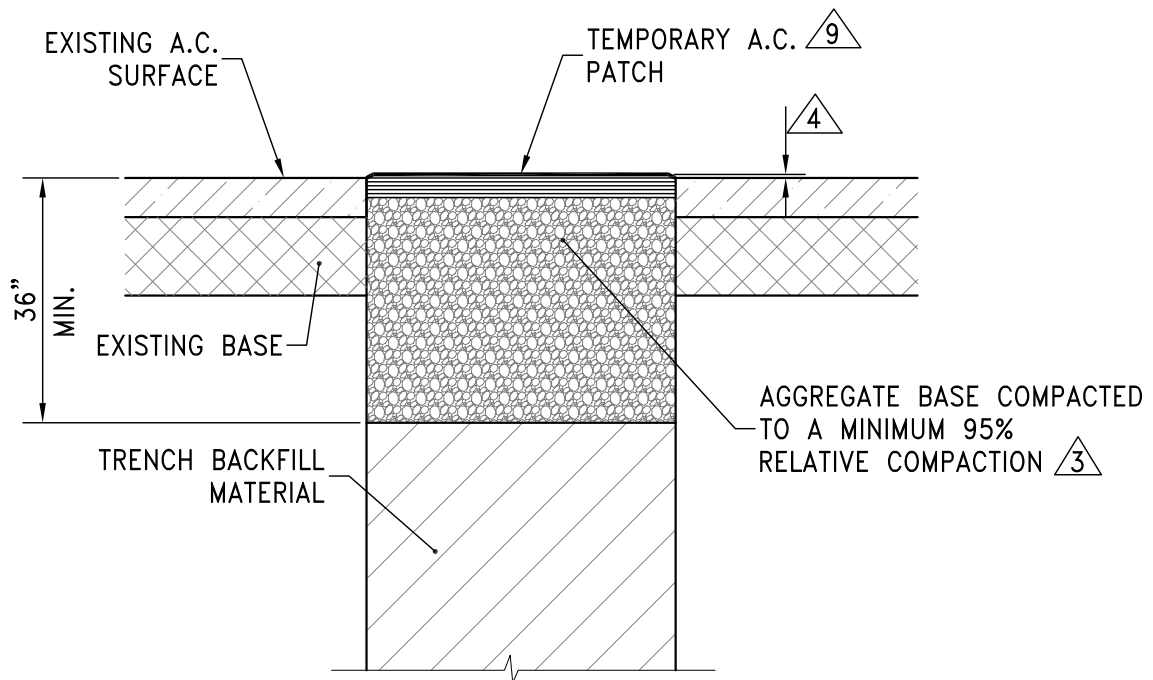

NOTES:

1. PRIOR TO EXCAVATION, THE OUTLINE OF THE TRENCH SHALL BE VERTICALLY CUT FULL DEPTH THROUGH THE EXISTING ASPHALT SURFACE.
2. CARE SHALL BE EXERCISED TO PREVENT SLOUGHING AND OVERBREAK. IF THE TRENCH SLOUGHS, THE SURFACE SHALL BE WIDENED TO ELIMINATE THE UNDERMINED SECTION OF ASPHALT.
3. AGGREGATE BASE UNDER TEMPORARY PATCH SHALL BE A MINIMUM THICKNESS OF 36 INCHES BELOW THE EXISTING AC SURFACE. AGGREGATE BASE MATERIAL UNDER TEMPORARY PATCH SHALL BE TYPE 2, CLASS B CRUSHED AGGREGATE BASE. MATERIALS SHALL CONFORM TO SSPWC SECTION 200.
4. TEMPORARY PATCHES SHALL BE PLACED AND COMPACTED. THE COMPACTED PATCH SHALL BE APPROXIMATELY 1/8" TO 1/4" ABOVE THE LEVEL OF THE ADJACENT PAVEMENT. IF NOT PATCHED WITHIN 24 HOURS AFTER BACKFILLING, THE CITY MAY PATCH AND BACK-CHARGE THE PERMITTEE FOR ALL COSTS.
5. COMPACTION OF BACKFILL, BASE AND A.C. TEMPORARY PATCH SHALL BE PERFORMED WITH APPROVED MECHANICAL TAMPERS. EQUIPMENT WHEEL ROLLING IS NOT PERMITTED.
6. ENTIRE AREA SHALL BE CLEANED OF ALL DIRT, DUST, DEBRIS, ETC. BEFORE LEAVING SITE. ANY SITE LEFT UNCLEANED WILL BE CLEANED BY THE CITY AND ALL COSTS BACK-CHARGED TO THE CONTRACTOR.
7. ALL EXCAVATIONS SHALL BE COMPLETE OR BACKFILLED AT THE END OF THE DAY.
8. TEMPORARY PATCH WORK AND PATCH MAINTENANCE SHALL BE THE RESPONSIBILITY OF THE CONTRACTOR.
9. ALL TEMPORARY PATCHES ON ALL STREETS SHALL BE HOT-MIX ASPHALT A MINIMUM OF 3" THICK.



STANDARD DETAILS FOR PUBLIC WORKS CONSTRUCTION

DRAWING No.

**TEMPORARY A.C.
TRENCH PATCH**

R-121

APPROVED BY: JF | DATE: 1/2013

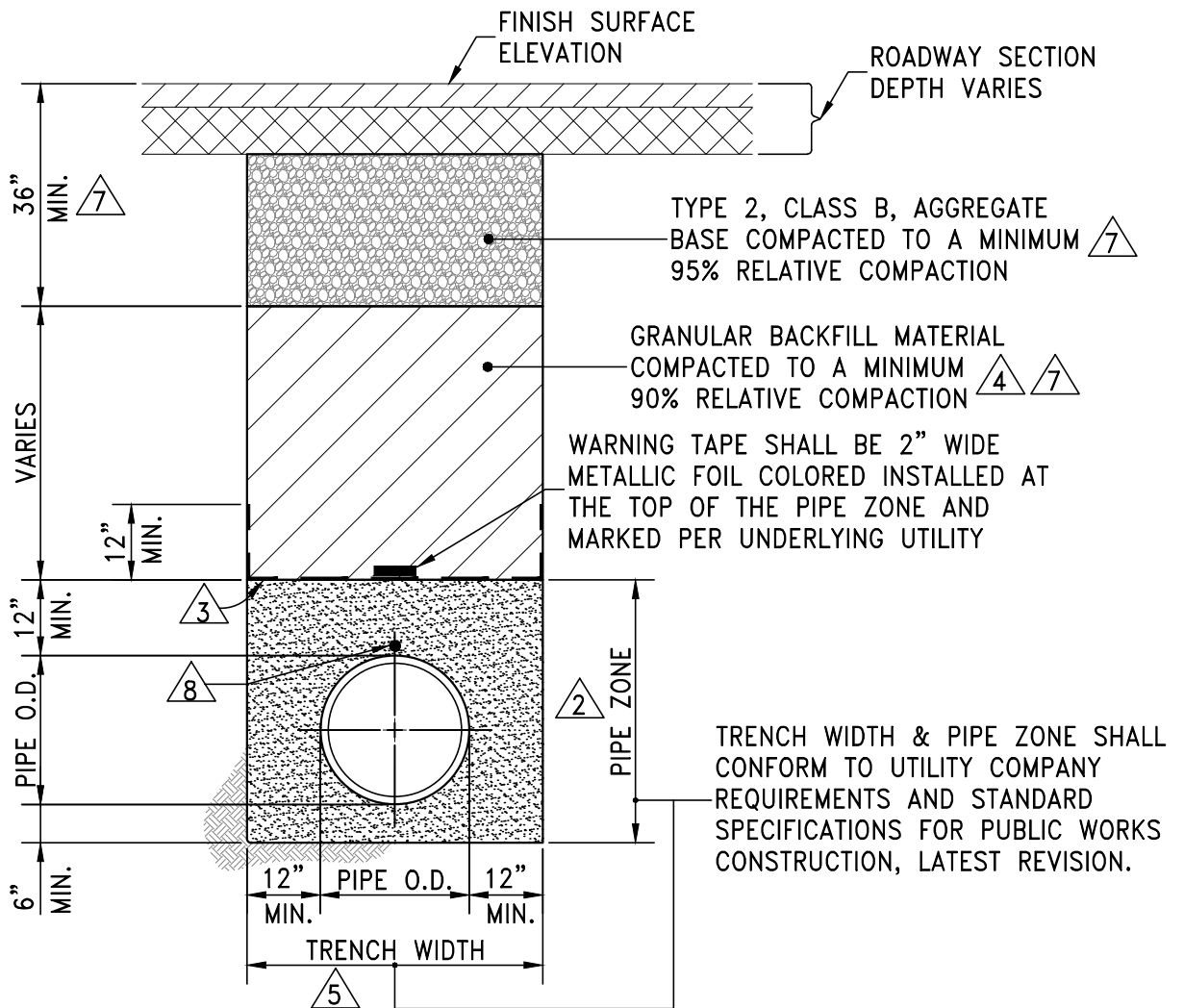

NOTES:

1. ALL MATERIALS AND INSTALLATION PROCEDURES SHALL BE IN ACCORDANCE WITH STANDARD SPECIFICATIONS FOR PUBLIC WORKS CONSTRUCTION (SSPWC), LATEST REVISION.
- $\triangle 2.$ BEDDING MATERIAL SHALL CONFORM TO OWNING-UTILITY COMPANY REQUIREMENTS AS APPROVED BY THE CITY OF RENO. FOR CITY-OWNED UTILITIES, BEDDING MATERIAL SHALL BE CLASS A OR C, COMPACTED TO MINIMUM 90% RELATIVE COMPACTION. MATERIALS SHALL CONFORM TO SSPWC SECTION 200.
- $\triangle 3.$ CLASS C BEDDING REQUIRES INSTALLATION OF GEOTEXTILE FABRIC BETWEEN PIPE ZONE AND BACKFILL MATERIAL. GEOTEXTILE FABRIC SHALL BE MIRAFI 180N OR APPROVED EQUAL.
- $\triangle 4.$ BACKFILL MATERIAL SHALL BE TYPE 2, CLASS B OR CLASS E AND COMPACTED TO MINIMUM 90% RELATIVE COMPACTION. MATERIALS SHALL CONFORM TO SSPWC SECTION 200.
- $\triangle 5.$ ALL EXCAVATIONS SHALL CONFORM TO THE LATEST O.S.H.A. REQUIREMENTS.
6. EXISTING PIPE TO BE ABANDONED SHALL BE GROUT FILLED OR COMPLETELY REMOVED.
- $\triangle 7.$ MINIMUM BACKFILL DEPTH REQUIREMENT IS FOR TRENCHING IN EXISTING PAVED STREETS. TRENCHING FOR NEW DEVELOPMENT WHERE STREETS HAVE NOT YET BEEN CONSTRUCTED, BACKFILL MATERIAL SHALL BE TYPE 2, CLASS B OR CLASS E AND COMPACTED TO MINIMUM 90% RELATIVE COMPACTION. MATERIALS SHALL CONFORM TO SSPWC SECTION 200.
- $\triangle 8.$ ALL PRESSURE MAINS SHALL INCLUDE TRACER WIRE. TRACER WIRE SHALL BE #14 AWG. TEST STATIONS SHALL BE CONSTRUCTED EVERY 1000 FEET. TEST STATIONS SHALL HAVE A MINIMUM OF 3 FEET OF COILED WIRE.



STANDARD DETAILS FOR PUBLIC WORKS CONSTRUCTION

DRAWING No.

**TRENCH
EXCAVATION/BACKFILL**

R-122

APPROVED BY: KK

DATE: 5/2024

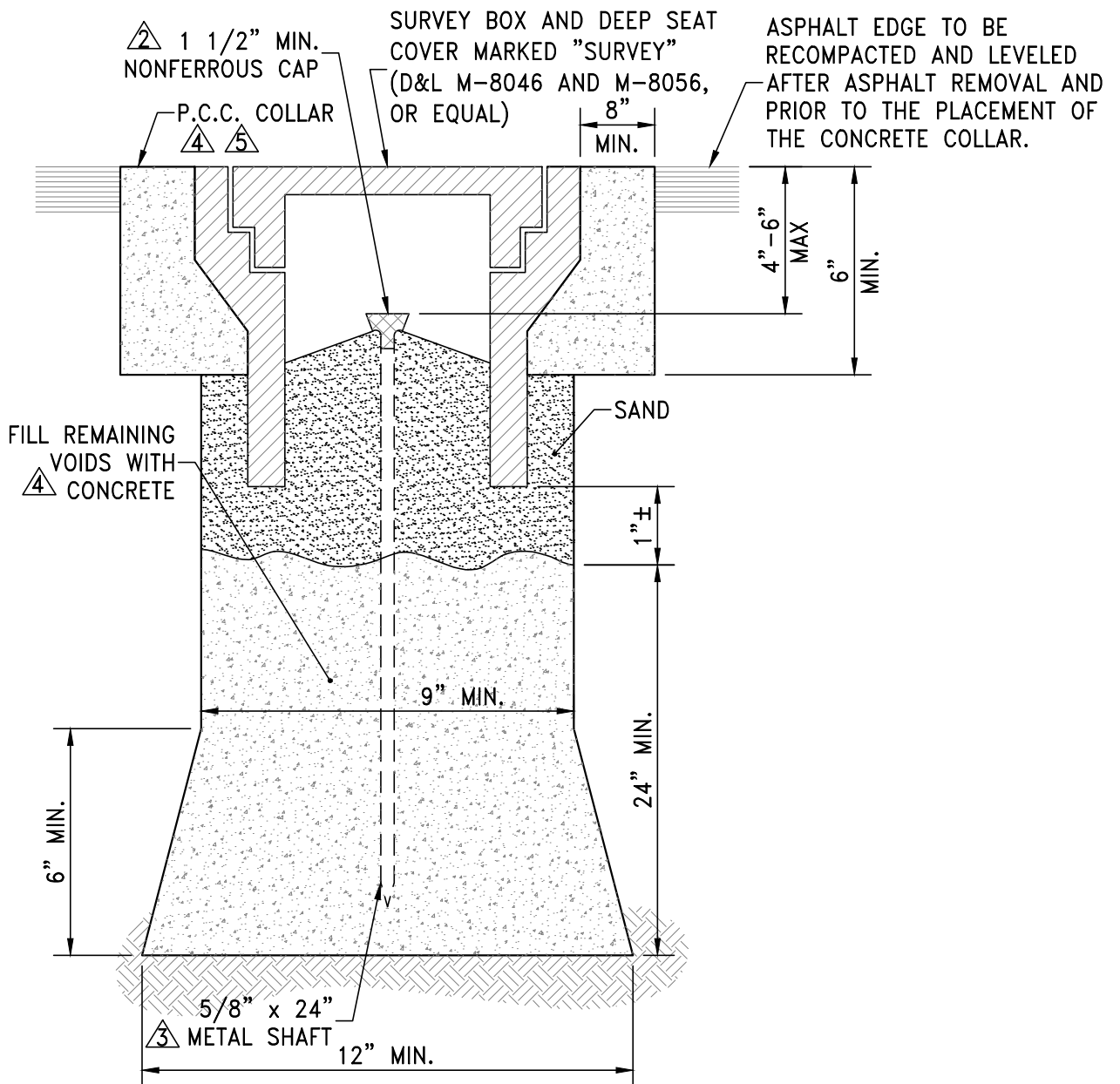

NOTES:

- ① FERROUS METAL OVER MONUMENT FOR RECOVERY BY DIP NEEDLE OR MAGNETIC INSERT IN CAP.
- ② 1 1/2" MIN. NONFERROUS CAP WITH PROFESSIONAL LAND SURVEYOR NO. PERMANENTLY ATTACHED PRIOR TO PLACEMENT. PRE-PUNCHED CAPS SHALL NOT BE PERMITTED
- ③ 5/8" METALLIC SHAFT (SMOOTH SHAFTS TO BE DEFORMED).
- ④ PORTLAND CEMENT CONCRETE (P.C.C.) SHALL BE 4000 PSI MIN. COMPRESSIVE STRENGTH AT 28 DAYS. ALL CEMENT CONCRETE SHALL HAVE A COARSE AGGREGATE GRADATION CONFORMING TO SIZE No. 67. POLYPROPYLENE OR CELLULOSE FIBERS SHALL BE ADDED TO THE P.C.C. AT 1.5 LBS PER CUBIC YARD. MIX DESIGN SHALL CONFORM TO THE REQUIREMENTS OF SECTION 337.10 OF SSPWC. ALL MATERIALS SHALL CONFORM TO SSPWC.
- ⑤ P.C.C. COLLARS IN ALL ROADWAYS SHALL BE PROTECTED FROM TRAFFIC LOADS UNTIL MINIMUM 3000 PSI IS ATTAINED.



STANDARD DETAILS FOR PUBLIC WORKS CONSTRUCTION

DRAWING No.

MONUMENTS

R-124

APPROVED BY: KK

DATE: 1/2023

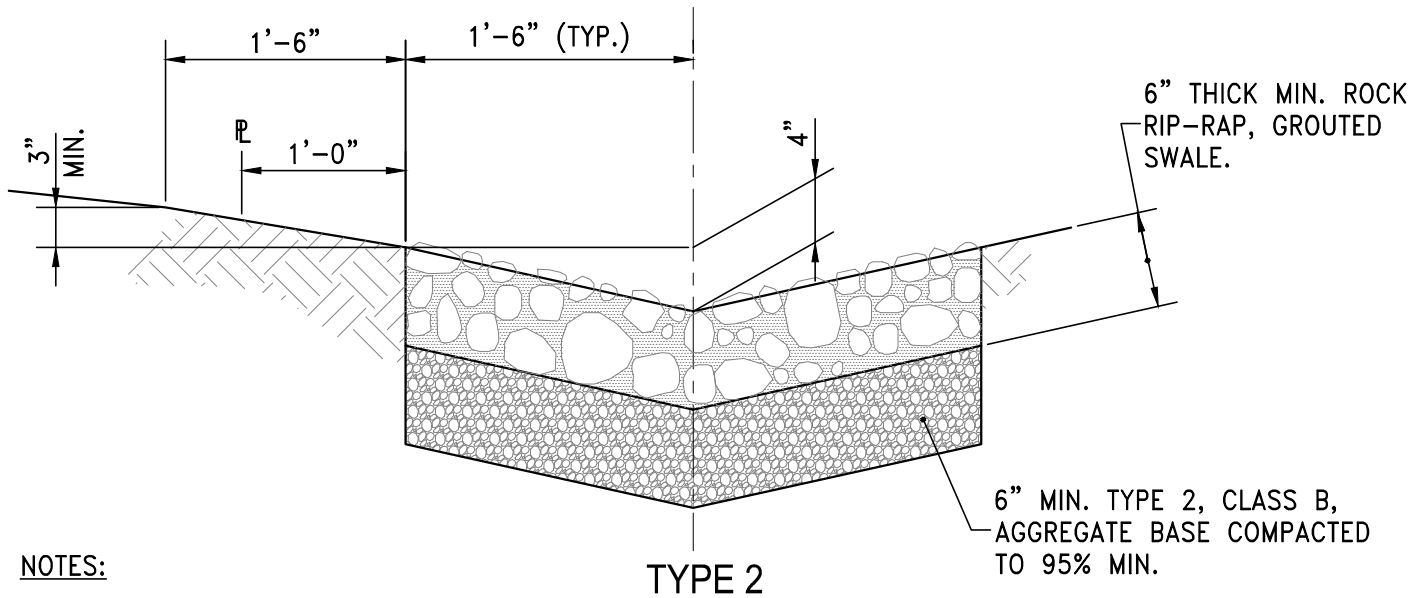
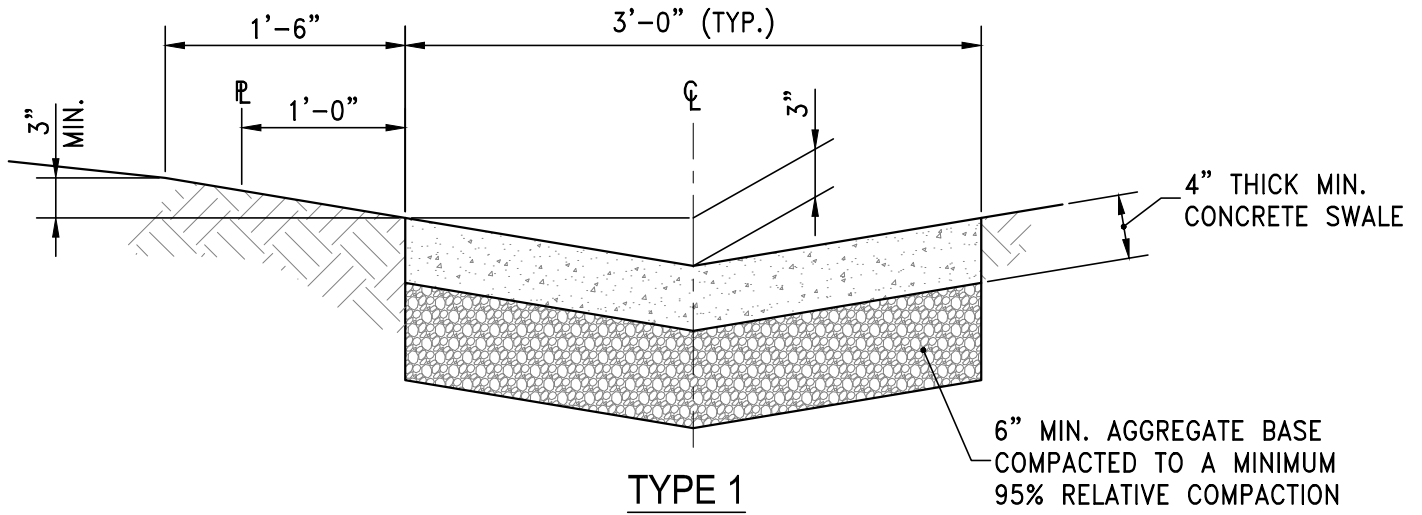

NOTES:

1. MAXIMUM DRAINAGE AREA SHALL BE 6 LOTS.
2. PORTLAND CEMENT CONCRETE (P.C.C.) SHALL BE 4000 PSI MIN. COMPRESSIVE STRENGTH AT 28 DAYS. ALL CEMENT CONCRETE SHALL HAVE A COARSE AGGREGATE GRADATION CONFORMING TO SIZE No. 67. POLYPROPYLENE OR CELLULOSE FIBERS SHALL BE ADDED TO THE P.C.C. AT 1.5 LBS PER CUBIC YARD. MIX DESIGN SHALL CONFORM TO THE REQUIREMENTS OF SECTION 337.10 OF SSPWC. ALL MATERIALS SHALL CONFORM TO SSPWC.
3. AGGREGATE BASE MATERIAL UNDER SIDEWALKS SHALL BE TYPE 2, CLASS B CRUSHED AGGREGATE BASE. MATERIALS SHALL CONFORM TO SSPWC SECTION 200.
4. MAXIMUM FLOWLINE GRADE FOR A TYPE I SHALL BE 6%.
5. MAXIMUM CHANGE IN HORIZONTAL ALIGNMENT SHALL BE 10 DEGREES.
6. P.C.C. DRAINAGE SWALES SHALL HAVE EXPANSION JOINTS EVERY 30 FEET AND WEAKENED PLANE JOINTS EVERY 10 FEET.



STANDARD DETAILS FOR PUBLIC WORKS CONSTRUCTION

DRAWING No.

**LOT LINE
DRAINAGE SWALE**

R-201

APPROVED BY: KK

DATE: 1/2023

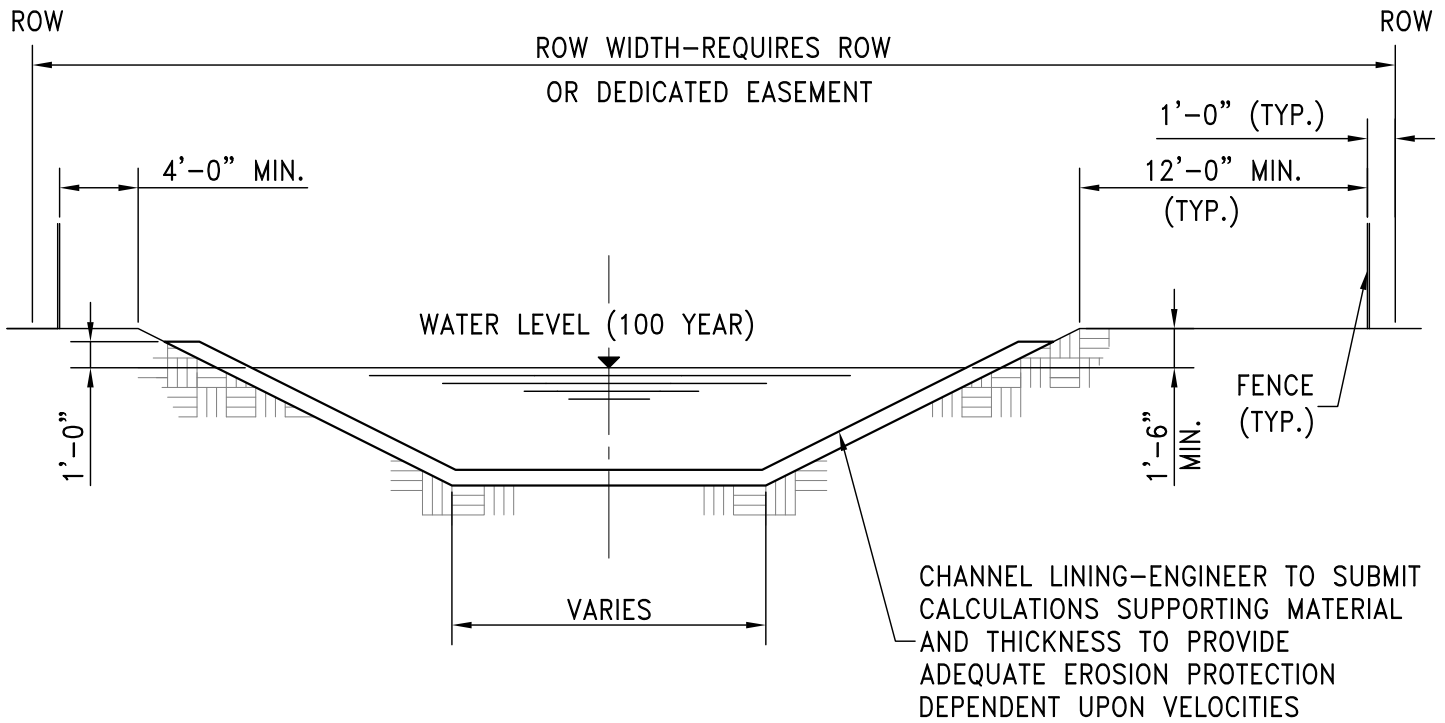

TYPICAL SECTION

NOTES:

1. REFER TO THE CITY OF RENO'S "PUBLIC WORKS DESIGN MANUAL" FOR MORE DETAILED DESIGN CRITERIA PERTAINING TO THIS DRAINAGE CHANNEL.
2. DESIGN VELOCITIES LESS THAN 6 FPS: CHANNEL LINING OF NON-ERODING, LONG LIFE, LOW MAINTENANCE MATERIAL AS APPROVED BY THE CITY ENGINEER. SIDE SLOPES 3:1 MAXIMUM UNLESS OTHERWISE APPROVED BY THE CITY ENGINEER.
3. DESIGN VELOCITIES 6 TO 10 FPS: CHANNEL LINING OF LOOSE ROCK RIP-RAP SIZED FOR VELOCITY. SIDE SLOPES 2:1 MAXIMUM.
4. DESIGN VELOCITIES GREATER THAN 10 FPS: CHANNEL LINING OF CONCRETE OR AN ENGINEERED EQUIVALENT. SIDE SLOPES 1:1 MAXIMUM.
5. PAVED ACCESS ROAD(S) SHALL BE CONSTRUCTED TO CITY STANDARDS WHEN DETERMINED NECESSARY BY THE CITY ENGINEER.
6. VEHICULAR ACCESS TO THE CHANNEL FLOOR FOR MAINTENANCE SHALL BE PROVIDED.
7. IF GROUTED RIP-RAP IS USED, ROCK GREATER THAN D_{50} OF 3" SHALL BE WET SET.



STANDARD DETAILS FOR PUBLIC WORKS CONSTRUCTION

DRAWING No.

MAJOR DRAINAGE CHANNEL

R-202
APPROVED BY: JF | DATE: 1/2013

NEENAH DRAINAGE GRATE R-4380
OR R-4385, D&L C-1012, OR
APPROVED EQUIVALENT.

NEENAH DRAINAGE GRATE R-4351
(BEEHIVE) MAY BE USED IN
LANDSCAPE AREAS.

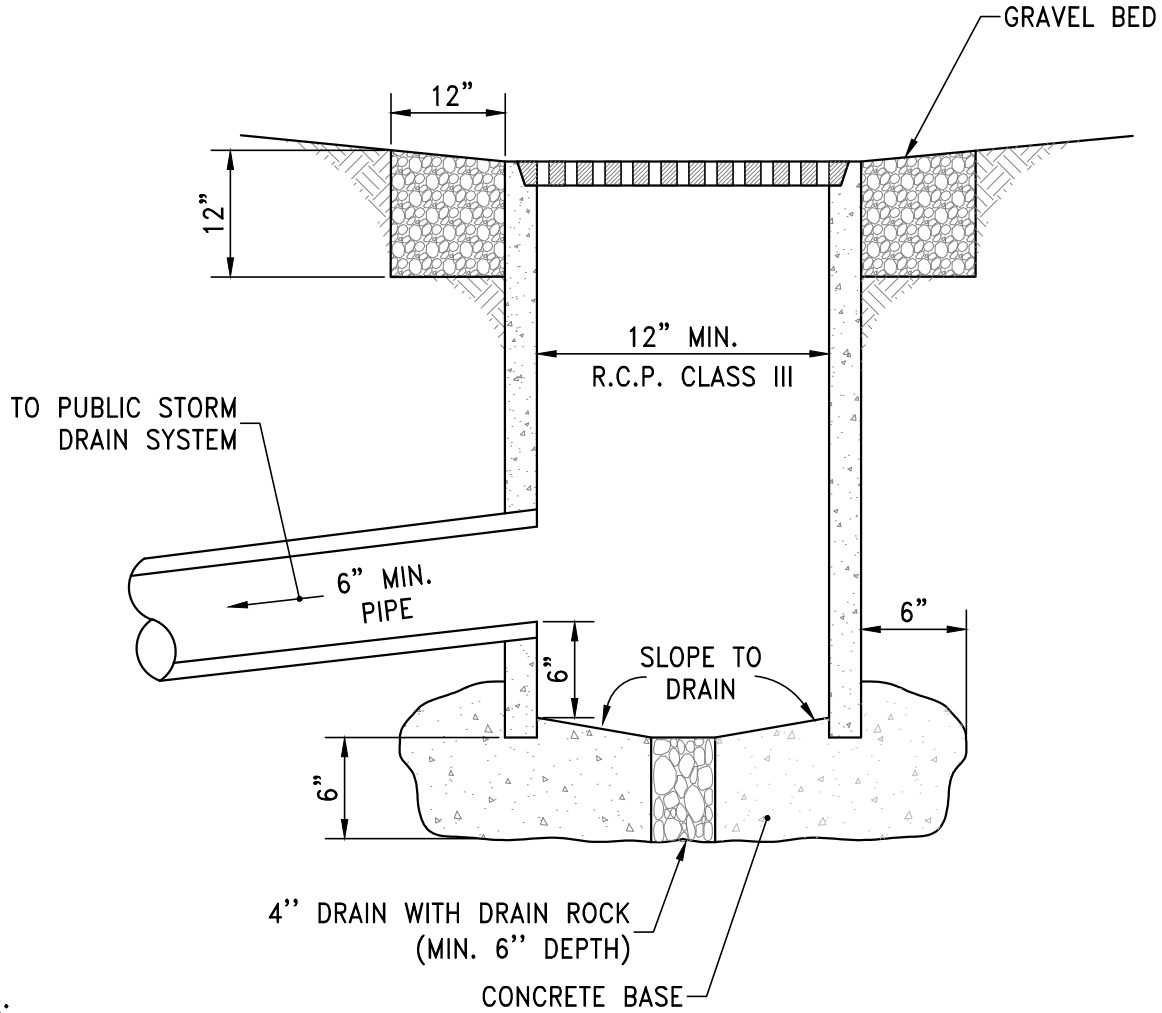
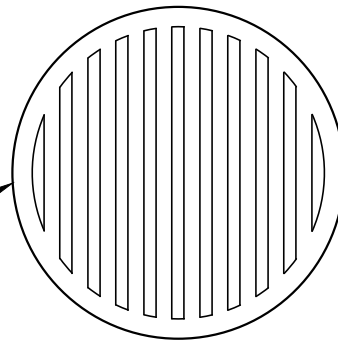

NOTES:

1. YARD DRAIN BASE SHALL BE PORTLAND CEMENT CONCRETE (P.C.C.) AND SHALL HAVE THE FOLLOWING CHARACTERISTICS: 4000 PSI MIN. COMPRESSIVE STRENGTH AT 28 DAYS. ALL CEMENT CONCRETE SHALL HAVE A COARSE AGGREGATE GRADATION CONFORMING TO SIZE No. 67. POLYPROPYLENE OR CELLULOSE FIBERS SHALL BE ADDED TO THE P.C.C. AT 1.5 LBS PER CUBIC YARD. MIX DESIGN SHALL CONFORM TO THE REQUIREMENTS OF SECTION 337.10 OF SSPWC. ALL MATERIALS SHALL CONFORM TO SSPWC.
2. TO BE OWNED AND MAINTAINED BY PRIVATE DEVELOPMENTS ONLY. NOT TO BE USED IN DRIVEWAYS OR WHERE DRAINAGE ORIGINATES FROM AREAS USED FOR VEHICULAR TRAFFIC.
3. ALL CATCH BASINS, PUBLIC OR PRIVATE, SHALL BE PROVIDED WITH A "SUR-TRAP" OIL/WATER SEPARATOR OR APPROVED EQUAL.
4. 12 INCH WIDE GRAVEL BED AROUND GRATE. NOMINAL AGGREGATE SIZE SHALL BE GREATER THAN GRATE OPENING.



STANDARD DETAILS FOR PUBLIC WORKS CONSTRUCTION

DRAWING No.

YARD DRAIN

R-203

APPROVED BY: KK

DATE: 1/2023

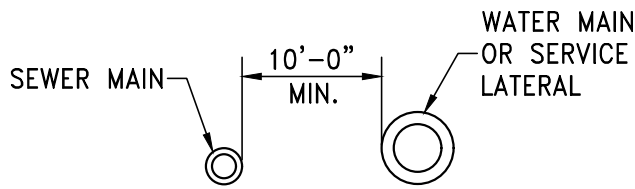

SEWER MAIN INSTALLATION PARALLEL TO WATER MAIN OR WATER SERVICE LATERAL (TYP.)

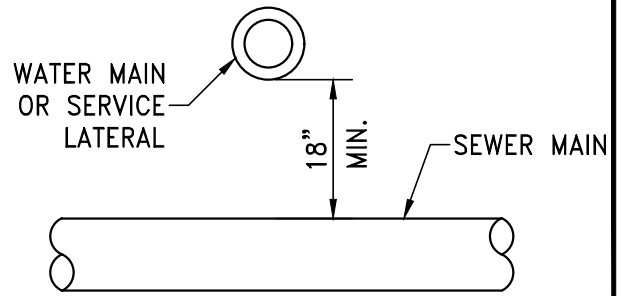

SEWER MAIN CROSSING WATER MAIN OR WATER SERVICE LATERAL (TYP.)

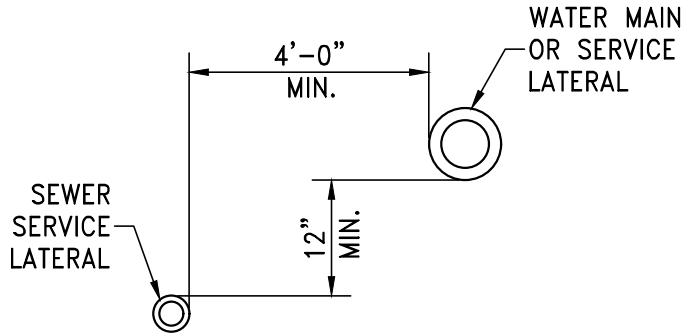

SEWER SERVICE LATERAL INSTALLATION PARALLEL TO WATER MAIN OR WATER SERVICE LATERAL (TYP.)

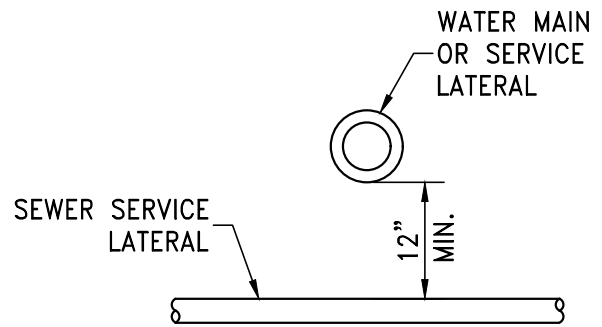

SEWER SERVICE LATERAL CROSSING WATER MAIN OR WATER SERVICE LATERAL (TYP.)

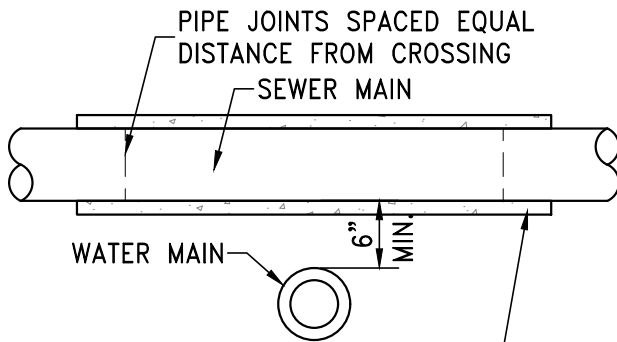

DUCTILE IRON SLEEVE OR CONCRETE ENCASUREMENT (SHOWN).
10' MIN. ON EACH SIDE OF CROSSING

SEWER MAIN CROSSING WATER MAIN (ALT.)

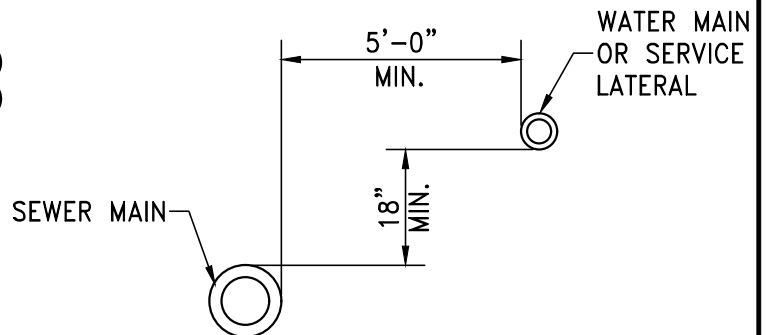

SEWER MAIN INSTALLATION PARALLEL TO WATER MAIN OR WATER SERVICE LATERAL (ALT.)

NOTES:

1. INSTALLATION OF SEWER LINES AND LATERALS SHALL BE IN CONFORMANCE WITH ALL STATE OF NEVADA WATER/SEWER SYSTEM SEPARATION REGULATIONS.
2. WHENEVER POSSIBLE, SEWER LINES AND LATERALS SHALL BE INSTALLED IN SEPARATE TRENCHES IN THE TYPICAL CONFIGURATIONS SHOWN ABOVE.
3. IF THE PIPE CANNOT BE INSTALLED IN THE TYPICAL OR ALTERNATIVE CONFIGURATIONS, THE CONTRACTOR SHALL HAVE WRITTEN APPROVAL FROM THE DIVISION OF HEALTH FOR ANY OTHER INSTALLATION CONFIGURATION.
4. REFER TO TMWA DETAILS FOR ADDITIONAL NOTES AND CONFIGURATIONS.



STANDARD DETAILS FOR PUBLIC WORKS CONSTRUCTION

**WATER / SEWER
SEPARATION**

DRAWING No.

R-204

APPROVED BY: KK

DATE: 2/2026

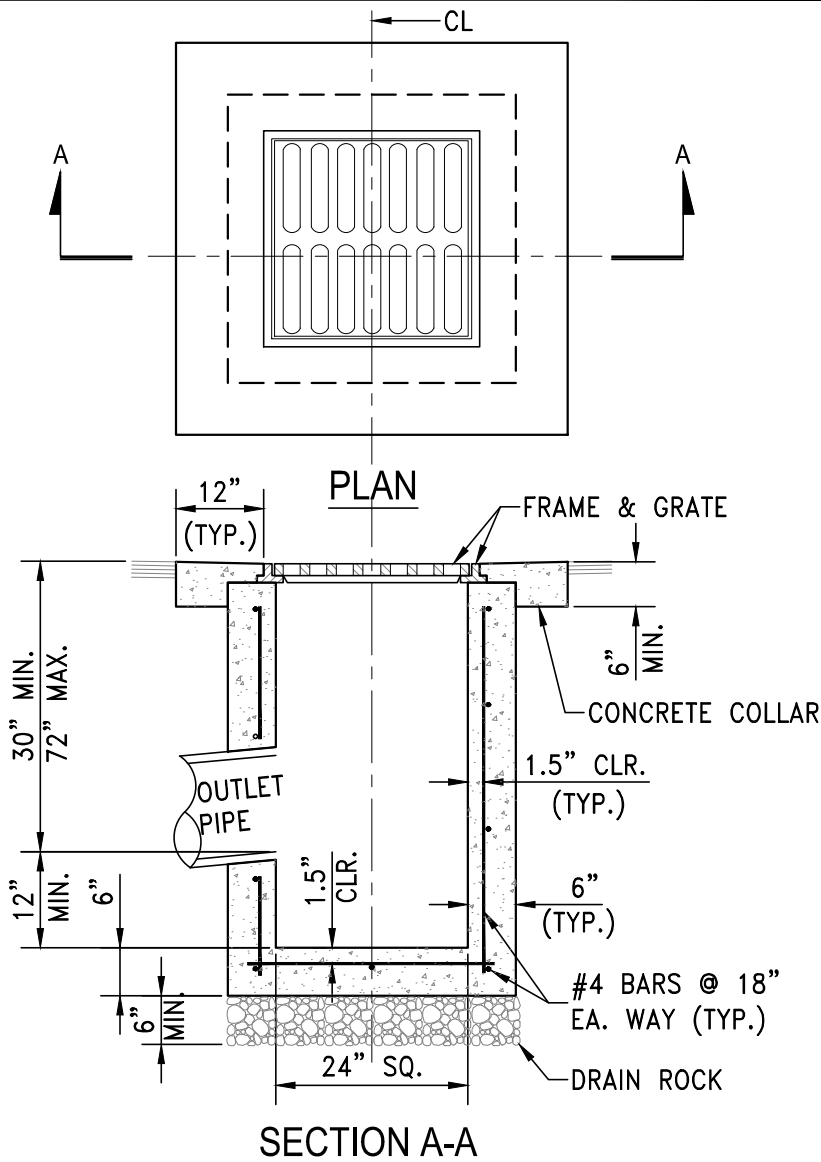

NOTES:

1. PORTLAND CEMENT CONCRETE (P.C.C.) SHALL BE 4000 PSI MIN. COMPRESSIVE STRENGTH AT 28 DAYS. ALL CEMENT CONCRETE SHALL HAVE A COARSE AGGREGATE GRADATION CONFORMING TO SIZE No. 67. POLYPROPYLENE OR CELLULOSE FIBERS SHALL BE ADDED TO THE P.C.C. AT 1.5 LBS PER CUBIC YARD. MIX DESIGN SHALL CONFORM TO THE REQUIREMENTS OF SECTION 337.10 OF SSPWC. ALL MATERIALS SHALL CONFORM TO SSPWC.
2. REINFORCING STEEL SHALL BE GRADE 40 AND HAVE 1.5" CLEAR COVER.
3. CONCRETE STRUCTURE MAY BE A PRE-CAST CONCRETE UNIT. BASE OF PRE-CAST CONCRETE UNIT SHALL BE PLACED ON 6" COMPACTED DRAIN ROCK.
4. FRAME & GRATE SHALL BE D&L I-9226 OR APPROVED EQUAL.
5. CATCH BASIN SHALL BE TRAFFIC-RATED AND USED ONLY AT LOW POINTS IN ALLEYS OR PARKING AREAS.
6. ALL CATCH BASINS, PUBLIC OR PRIVATE, SHALL BE PROVIDED WITH A "SUR-TRAP" OIL/WATER SEPARATOR OR APPROVED EQUAL.



STANDARD DETAILS FOR PUBLIC WORKS CONSTRUCTION

DRAWING No.

**CATCH BASIN
TYPE 3-R**

R-205

APPROVED BY: KK

DATE: 1/2023

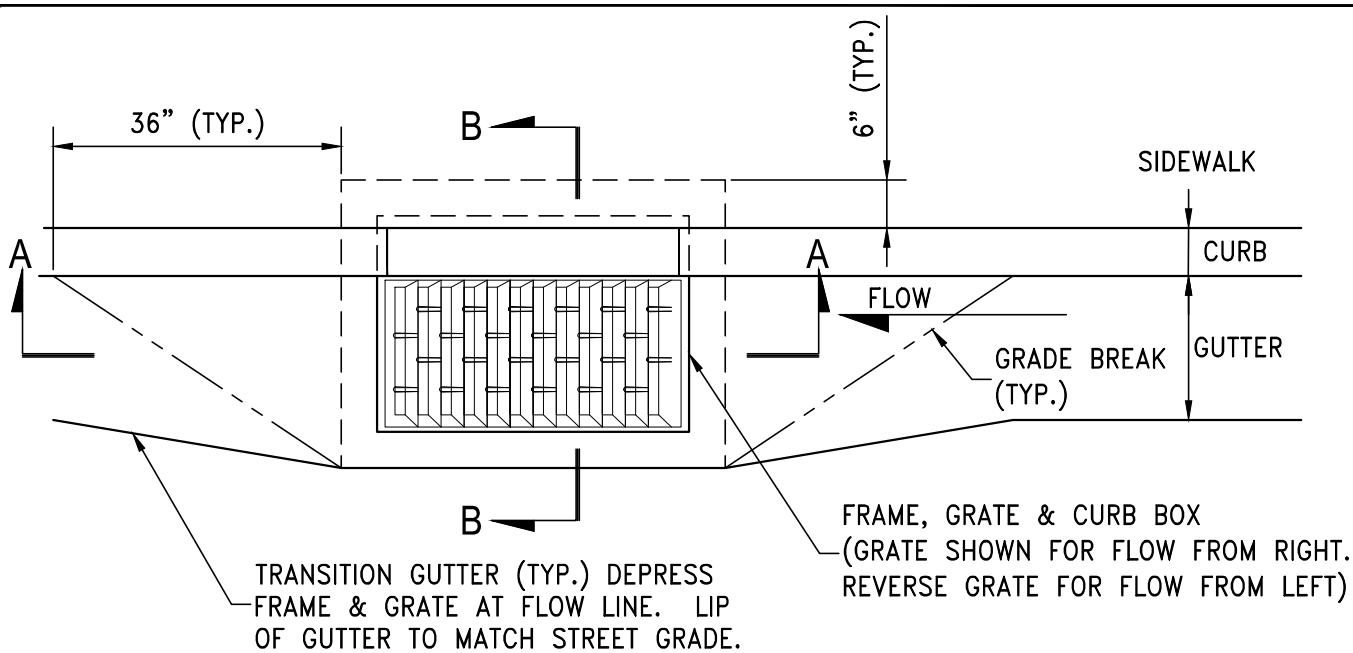

PLAN

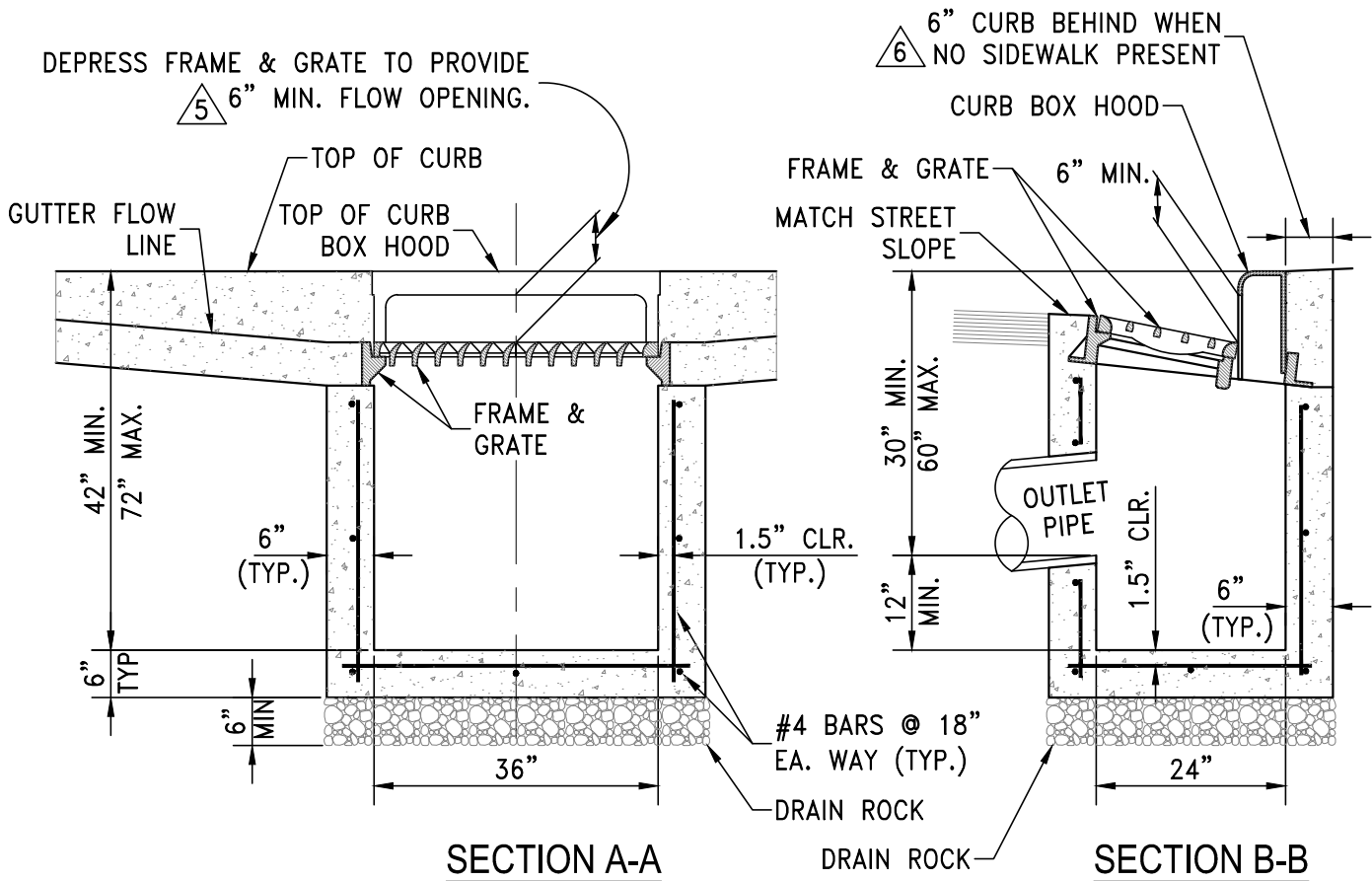

STANDARD DETAILS FOR PUBLIC WORKS CONSTRUCTION

DRAWING No.

**CATCH BASIN
TYPE 4-R**

R-206A

APPROVED BY: KK

DATE: 1/2023

NOTES:

1. PORTLAND CEMENT CONCRETE (P.C.C.) SHALL BE 4000 PSI MIN. COMPRESSIVE STRENGTH AT 28 DAYS. ALL CEMENT CONCRETE SHALL HAVE A COARSE AGGREGATE GRADATION CONFORMING TO SIZE No. 67. POLYPROPYLENE OR CELLULOSE FIBERS SHALL BE ADDED TO THE P.C.C. AT 1.5 LBS PER CUBIC YARD. MIX DESIGN SHALL CONFORM TO THE REQUIREMENTS OF SECTION 337.10 OF SSPWC. ALL MATERIALS SHALL CONFORM TO SSPWC.
2. REINFORCING STEEL SHALL BE GRADE 40 AND HAVE 1.5" MINIMUM CLEAR COVER.
3. CONCRETE STRUCTURE MAY BE A PRE-CAST CONCRETE UNIT UPON APPROVAL OF THE CITY ENGINEER. BASE OF PRE-CAST CONCRETE UNIT SHALL BE PLACED ON 6" COMPACTED DRAIN ROCK.
4. FRAME, GRATE AND CURB BOX HOOD ASSEMBLY SHALL BE D&L I-3519 WITH TYPE L "VANE GRATE" OR APPROVED EQUAL. GRATE SHALL BE INSTALLED WITH PROPER FLOW DIRECTION. EACH CATCH BASIN SHALL BE CAST WITH A FISH IMAGE AND THE WORDS "NO DUMPING! DRAINS TO WATERWAYS" IN THE TOP OF EACH CURB HOOD.
5. TILT FRAME & GRATE AS REQUIRED TO ATTAIN 6" MIN. FLOW OPENING & INSTALL DURABLE SHIMS BETWEEN THE CURB BOX & FRAME AS REQUIRED TO MATCH CURB BOX TO TOP OF CURB AND FACE OF CURB (SEE SECTION B-B).
6. WHEN SIDEWALK IS PRESENT CONCRETE BEHIND CURB BOX SHALL BE THICKENED TO THE FULL DEPTH OF THE CURB BOX. IF NO SIDEWALK IS PRESENT, POUR 6" CONCRETE CURB STRUCTURE BEHIND GRATE AND TIE BEAM INTO BOX.
7. ALL CATCH BASINS, PUBLIC OR PRIVATE, SHALL BE PROVIDED WITH A "SUR-TRAP" OIL/WATER SEPARATOR OR APPROVED EQUAL.
8. FRAMES AND GRATES SHALL BE MATCHED TO ACHIEVE A CLOSE TOLERANCE FIT WITH MINIMAL GAPS.
9. CATCH BASIN SHALL NOT BE PLACED WITHIN THE RADIUS OF THE CURB.



STANDARD DETAILS FOR PUBLIC WORKS CONSTRUCTION

DRAWING No.

NOTES

R-206B

CATCH BASIN TYPE 4-R

APPROVED BY: KK | DATE: 1/2023

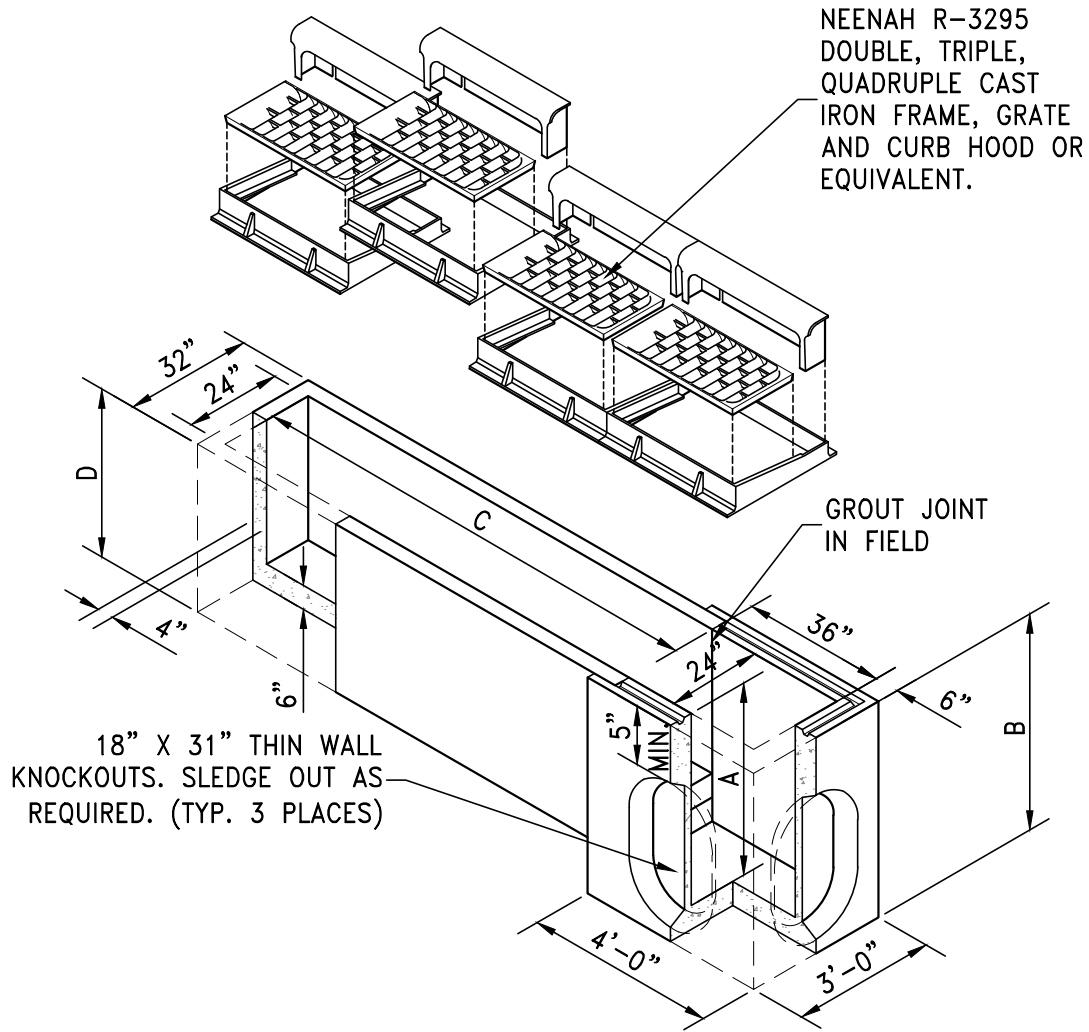

NOTES:

1. A HIGH CAPACITY CURB INLET SHALL BE USED WHEN DESIGN FLOW RATES EXCEED THE CAPACITY OF A SINGLE CATCH BASIN.
2. FOR DIMENSIONS, NOTES, AND DETAILS NOT SHOWN, REFER TO THE APPLICABLE CATCH BASIN DETAIL DRAWINGS.



STANDARD DETAILS FOR PUBLIC WORKS CONSTRUCTION

DRAWING No.

HIGH CAPACITY CURB INLET

R-207A

APPROVED BY: JF DATE:12/2019

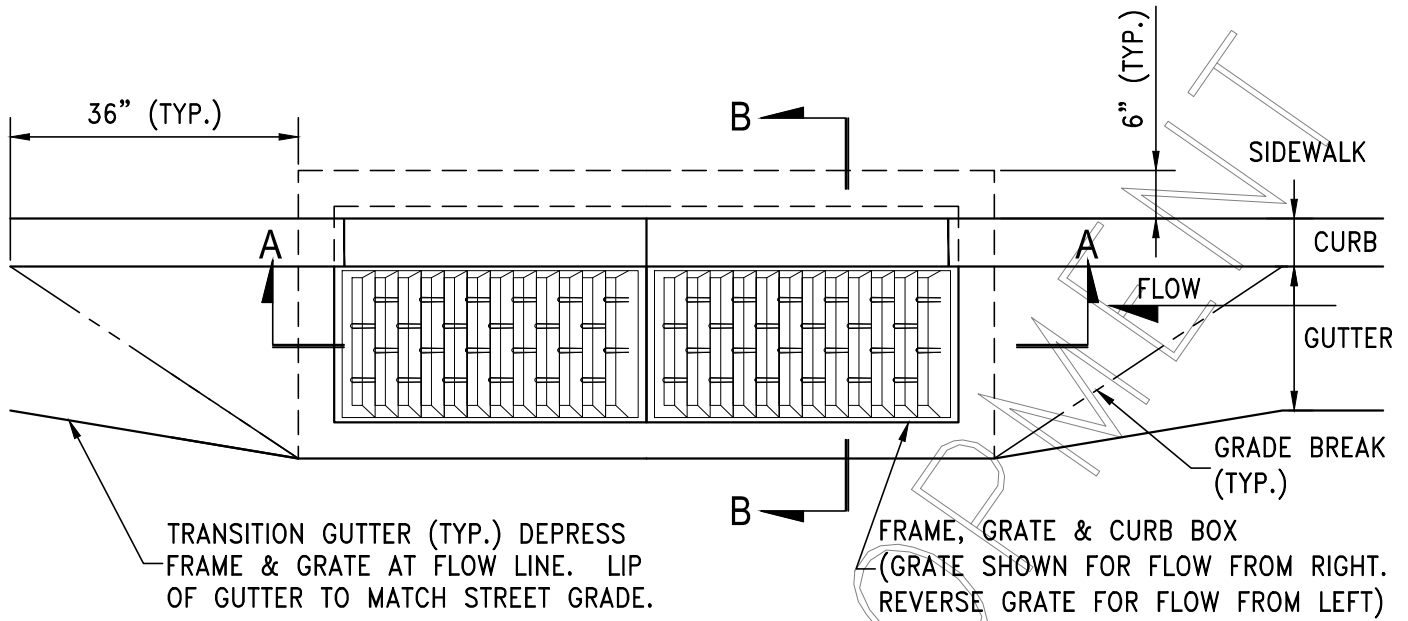

PLAN

NEENAH R-3295 DOUBLE CAST IRON FRAME, GRATE, AND CURB HOOD OR APPROVED EQUAL

6" CURB BEHIND WHEN NO SIDEWALK PRESENT

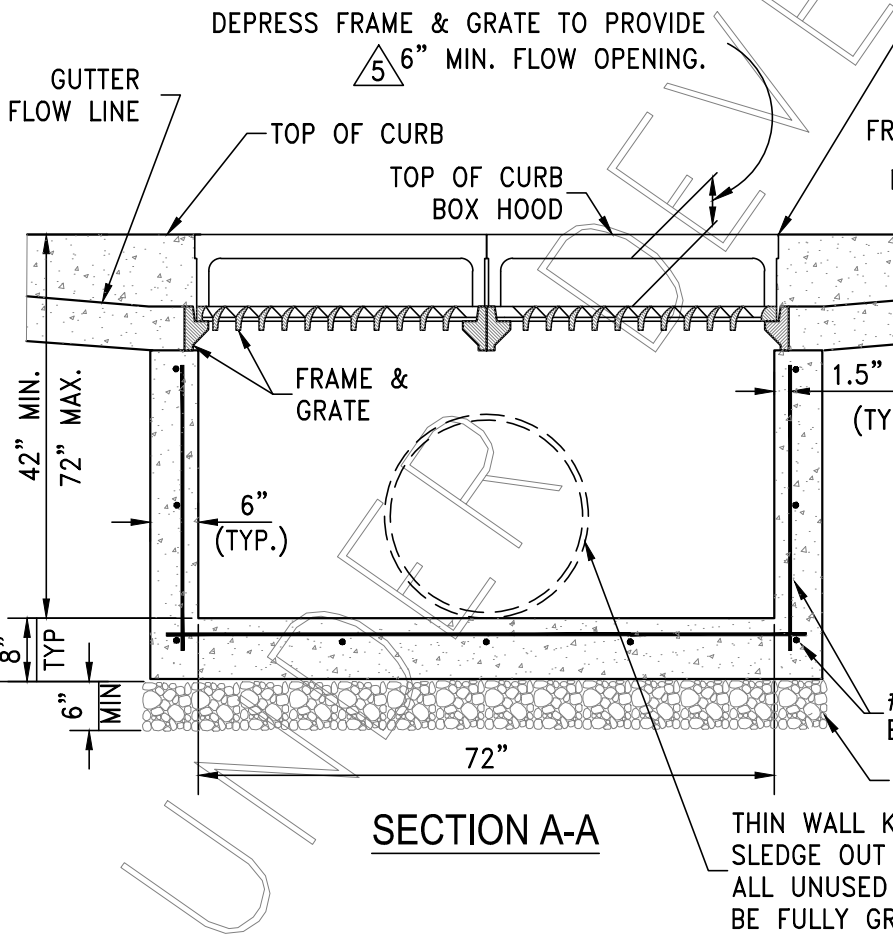

DEPRESS FRAME & GRATE TO PROVIDE 6" MIN. FLOW OPENING.

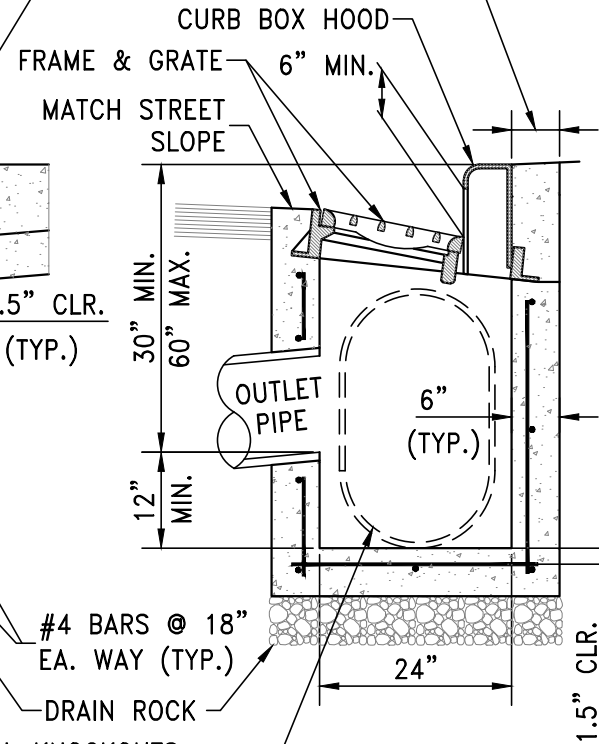

#4 BARS @ 18" EA. WAY (TYP.)

DRAIN ROCK

THIN WALL KNOCKOUTS. SLEDGE OUT AS REQUIRED. ALL UNUSED AREA SHOULD BE FULLY GROUTED.



STANDARD DETAILS FOR PUBLIC WORKS CONSTRUCTION

**CATCH BASIN
DUAL TYPE 4-R**

DRAWING No.

R-207B

APPROVED BY: JC

DATE: 12/2019

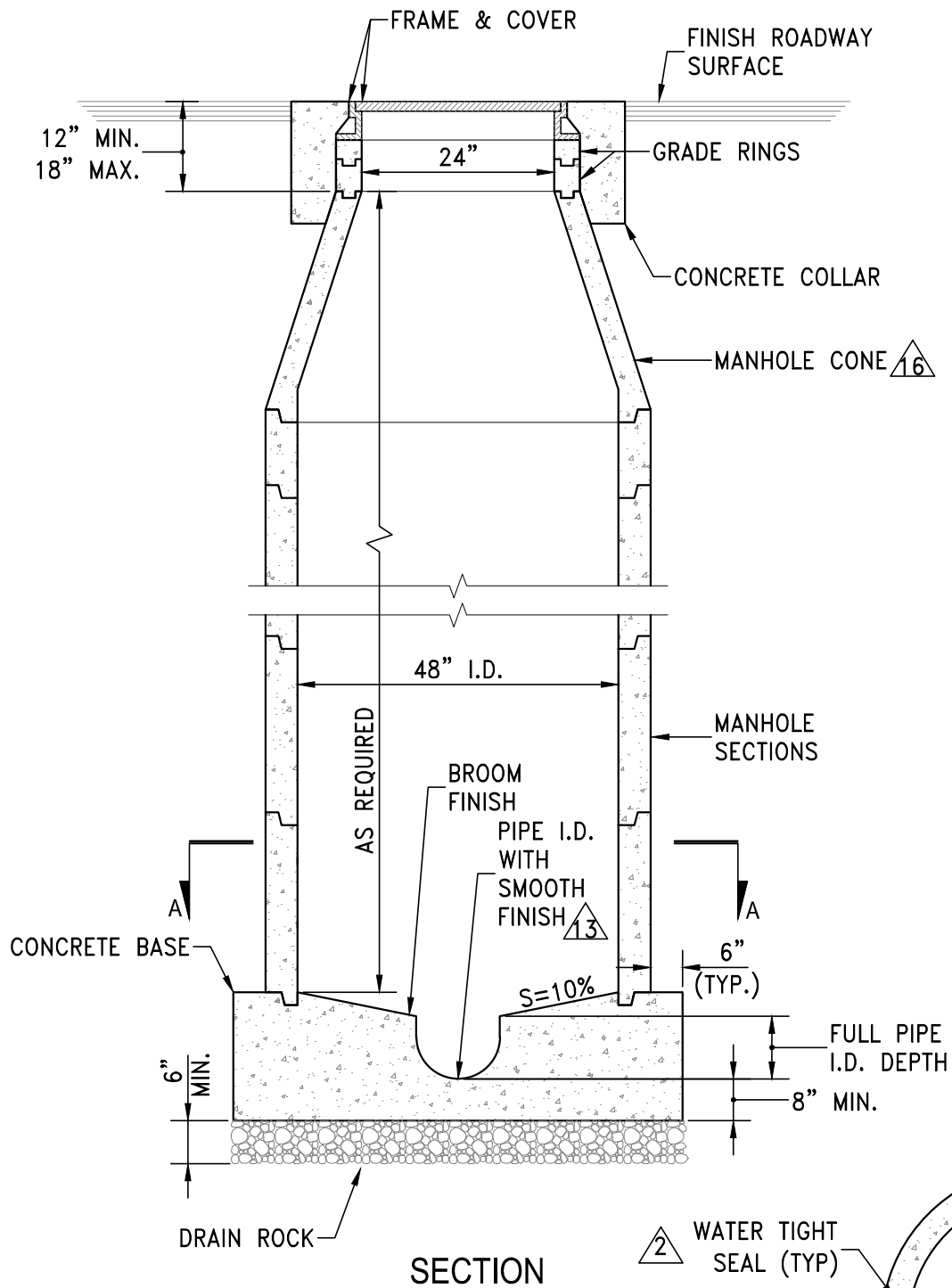

SECTION

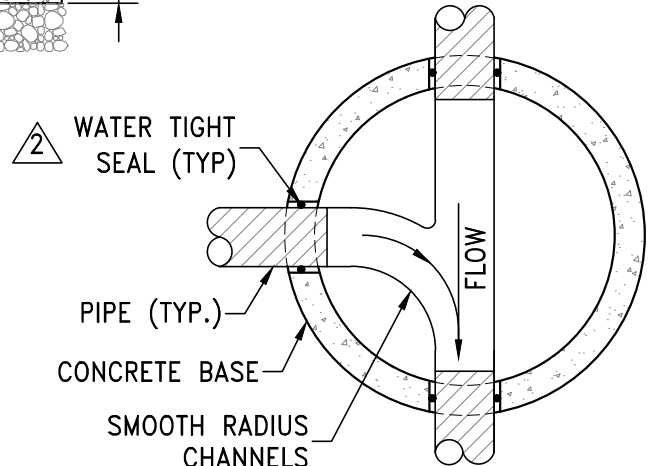

SECTION A-A



STANDARD DETAILS FOR PUBLIC WORKS CONSTRUCTION

DRAWING No.

MANHOLE TYPE I

R-208A

APPROVED BY: KK DATE: 1/2023

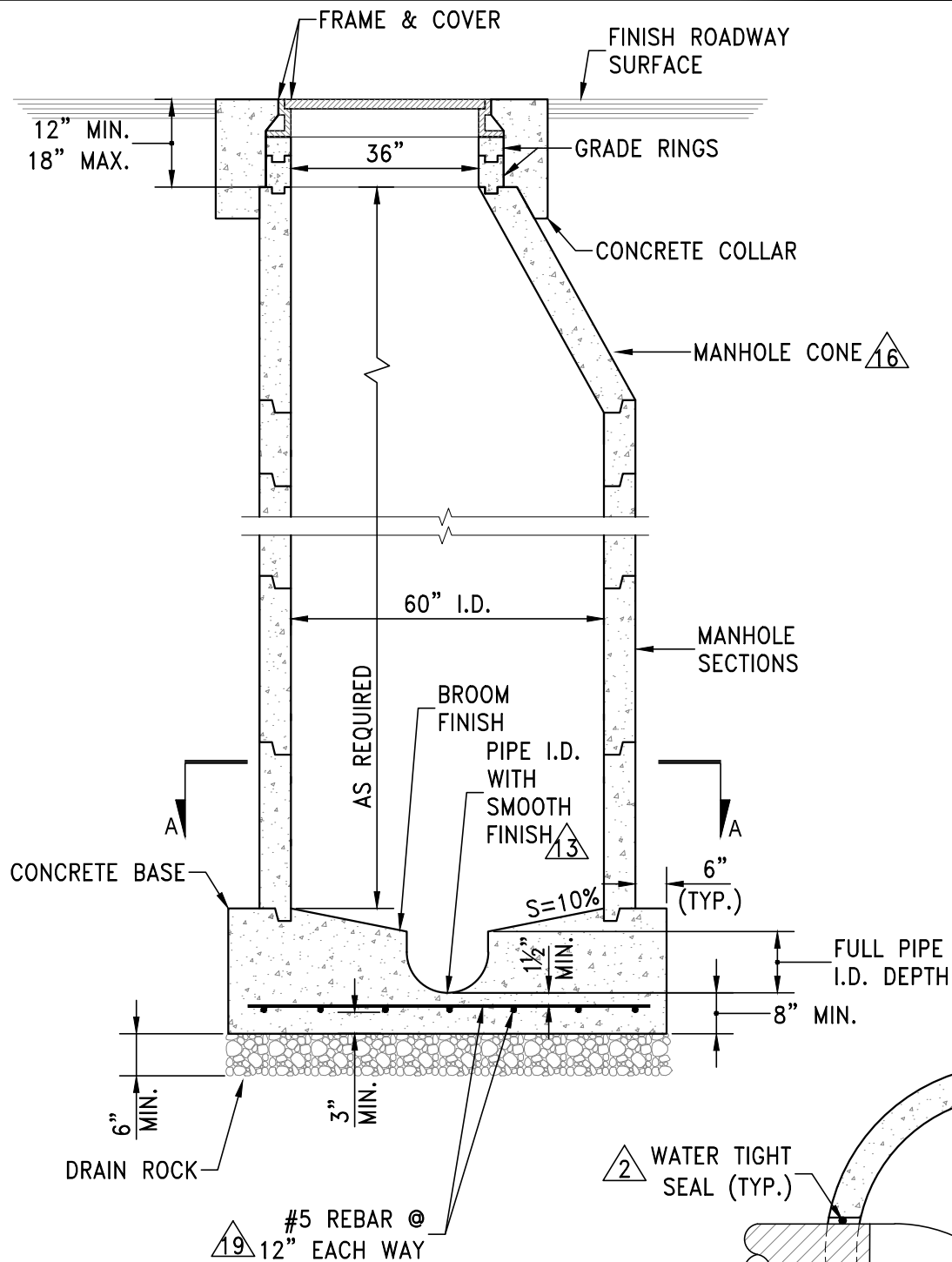

SECTION

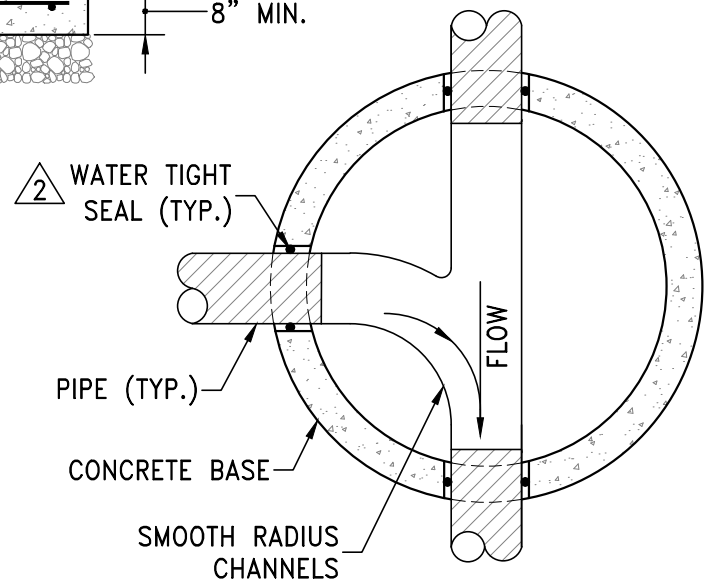

SECTION A-A



STANDARD DETAILS FOR PUBLIC WORKS CONSTRUCTION

DRAWING No.

MANHOLE TYPE V

R-208B

APPROVED BY: KK

DATE: 1/2023

GENERAL MANHOLE NOTES

1. ALL PRECAST MANHOLE COMPONENTS SHALL CONFORM TO ASTM C-478.
2. PIPES SHALL NOT PROTRUDE MORE THAN 3" INSIDE MANHOLE SECTION AS MEASURED AT THE OUTSIDE EDGES OF THE PIPE, VERTICALLY ALIGNED WITH THE SPRINGLINE. PIPE CONNECTION TO MANHOLE SHALL BE WATERTIGHT PER STANDARD DETAILS R-223A, R-223B AND R-223C.
3. MANHOLE BASE SHALL BE PORTLAND CEMENT CONCRETE (P.C.C.) AND SHALL HAVE THE FOLLOWING CHARACTERISTICS: 4000 PSI MIN. COMPRESSIVE STRENGTH AT 28 DAYS. ALL CEMENT CONCRETE SHALL HAVE A COARSE AGGREGATE GRADATION CONFORMING TO SIZE No. 67. POLYPROPYLENE OR CELLULOSE FIBERS SHALL BE ADDED TO THE P.C.C. AT 1.5 LBS PER CUBIC YARD. MIX DESIGN SHALL CONFORM TO THE REQUIREMENTS OF SECTION 337.10 OF SSPWC. ALL MATERIALS SHALL CONFORM TO SSPWC.
4. TYPE I MANHOLE TO BE UTILIZED FOR PIPE DIAMETERS OF 12" OR SMALLER AND DEPTHS NOT EXCEEDING 18 FEET.
5. TYPE V MANHOLE TO BE UTILIZED FOR PIPE DIAMETERS OF 15" THROUGH 27" OR DEPTHS EXCEEDING 18 FEET.
6. MANHOLE MATERIALS AND CONSTRUCTION SHALL CONFORM TO THE REQUIREMENTS OF SECTION 204 "MANHOLES AND CATCH BASINS" OF THE STANDARD SPECIFICATIONS.
7. PRECAST MANHOLE SECTIONS, OTHER THAN GRADE RINGS, SHALL BE JOINED WITH FLEXIBLE GASKET MATERIAL SUCH AS "RAM-NEK" OR EQUAL AS PER MANUFACTURER'S RECOMMENDATIONS.
8. EXCAVATION AND BACKFILL SHALL BE AS SPECIFIED FOR "TRENCH EXCAVATION AND BACKFILL" IN SECTION 305 OF THE STANDARD SPECIFICATIONS.
9. EXCAVATION SHALL BE AS NEARLY VERTICAL AS POSSIBLE (SHEET AND SHORE IF SOIL CONDITIONS REQUIRE) IN EXISTING STREET SECTIONS, ALLEY SECTIONS, AND CONFINED AREAS, SUCH AS LIMITED EASEMENTS OR ADJACENT STRUCTURES.
10. MANHOLE PRECAST SECTION LENGTH SHALL BE ARRANGED TO FIT THE REQUIRED DEPTH.
11. NO LATERALS OR PIPES LESS THAN 8" IN DIAMETER SHALL BE CONNECTED TO THE MANHOLE.
12. PRECAST CONCRETE BASE MAY BE USED IN LIEU OF CAST-IN-PLACE BASE.
13. MATCH PIPE INVERTS TO MANHOLE INVERTS WHERE PIPES CONNECT TO MANHOLE BASE.
14. ALL MANHOLES SHALL BE WATERTIGHT.
15. SEE DETAIL FOR OUTSIDE DROP MANHOLE FOR SANITARY SEWERS WITH MORE THAN 2 FEET VERTICAL DROP AT THE MANHOLE. THE USE OF "INSIDE DROP" MANHOLES IS NOT PERMITTED.
16. THE USE OF FLAT TOP MANHOLE CONES REQUIRES PRIOR APPROVAL FROM THE CITY ENGINEER.
17. PRIOR TO BACKFILLING, ALL MANHOLES SHALL BE VACUUM TESTED PER ASTM C-1244.
18. NO STEPS, LADDERS, OR OTHER CLIMBING DEVICES SHALL BE INSTALLED IN THE MANHOLE.
19. REINFORCING STEEL SHALL BE AS SHOWN, WIRED TIGHTLY AT ALL INTERSECTIONS AND EMBEDDED AT LEAST 1½" CLEAR, UNLESS OTHERWISE NOTED.
20. WHEN PIPE CONNECTIONS TO EXISTING MANHOLES ARE ALLOWED, THEY SHALL BE MADE BY CORE DRILLING THE MANHOLE AND CONNECTING THE PIPE PENETRATION PER DETAIL R-223A & R-223B.



STANDARD DETAILS FOR PUBLIC WORKS CONSTRUCTION

**NOTES - MANHOLE
TYPE I & TYPE V**

DRAWING No.

R-208C

APPROVED BY: KK | DATE: 1/2023

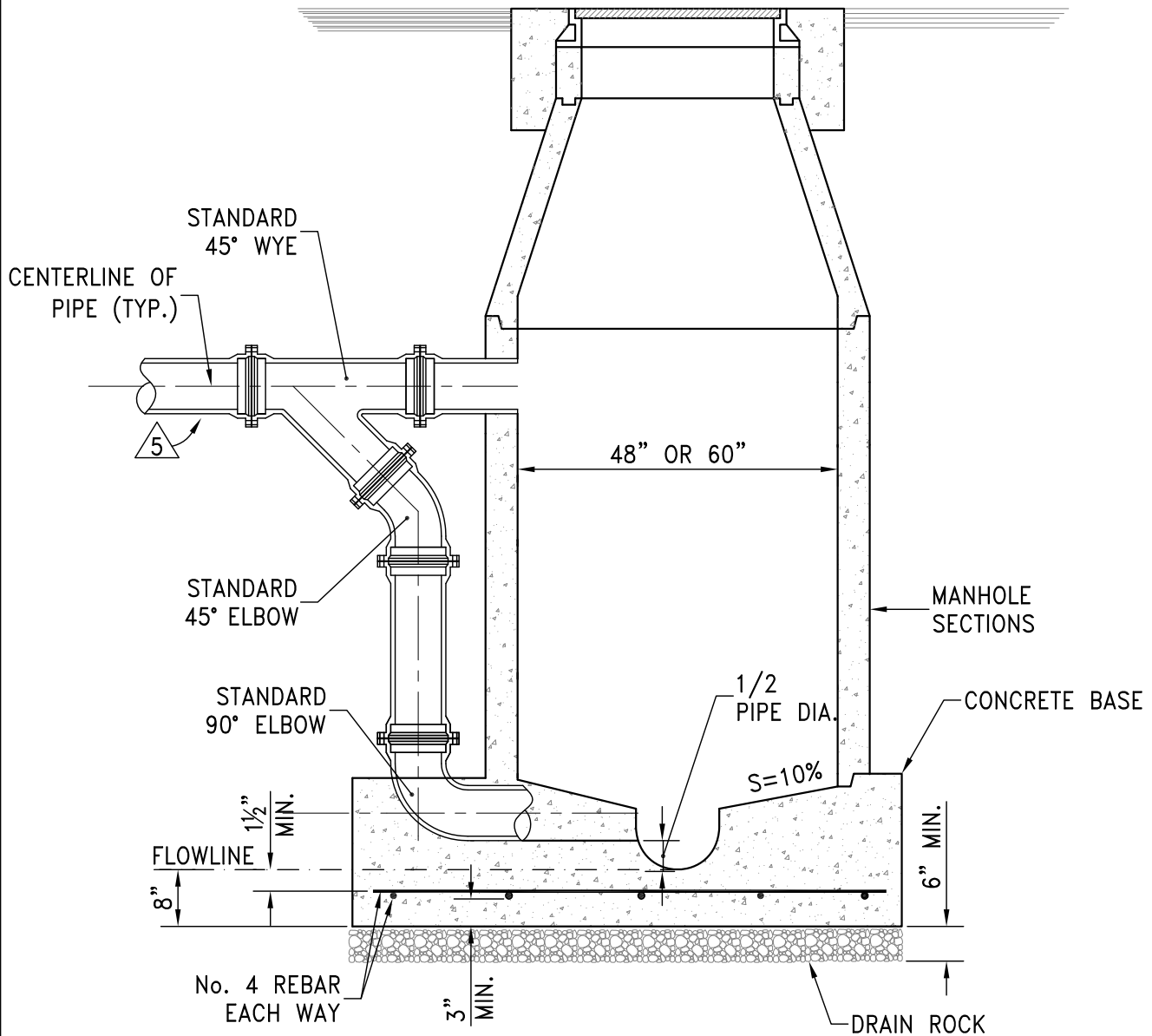

1. DETAIL FOR OUTSIDE DROP ASSEMBLY ONLY. FOR DIMENSIONS, NOTES AND DETAILS NOT SHOWN, REFER TO THE APPLICABLE STANDARD DETAIL DRAWING.
 2. CONSTRUCTION OF AN OUTSIDE DROP MANHOLE MUST BE APPROVED IN WRITING BY THE CITY ENGINEER IN ADVANCE OF ANY CONSTRUCTION.
 3. OUTSIDE DROP MANHOLES ARE TO BE USED ON SANITARY SEWERS WITH MORE THAN 2 FEET VERTICAL DROP AT THE MANHOLE, NOT TO EXCEED 8 FEET, UNLESS OTHERWISE APPROVED BY THE CITY ENGINEER.
 4. SANITARY SEWER PIPE COMPONENTS OF THE OUTSIDE DROP CONFIGURATION SHALL BE DUCTILE IRON PIPE WITH MECHANICAL JOINT FITTINGS PER AWWA A21.51-02.
5. INSTALL ONE FULL LENGTH OF DUCTILE IRON PIPE (MIN. LENGTH 20') BEYOND THE UPSTREAM END OF THE STANDARD 45° WYE.
6. DUCTILE IRON MATERIAL TO BE LINED AND COATED PER AWWA A21.51-02.

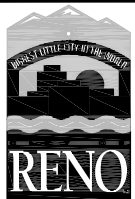

STANDARD DETAILS FOR PUBLIC WORKS CONSTRUCTION

DRAWING No.

MANHOLE-OUTSIDE DROP

R-209

APPROVED BY: JF

DATE: 1/2013

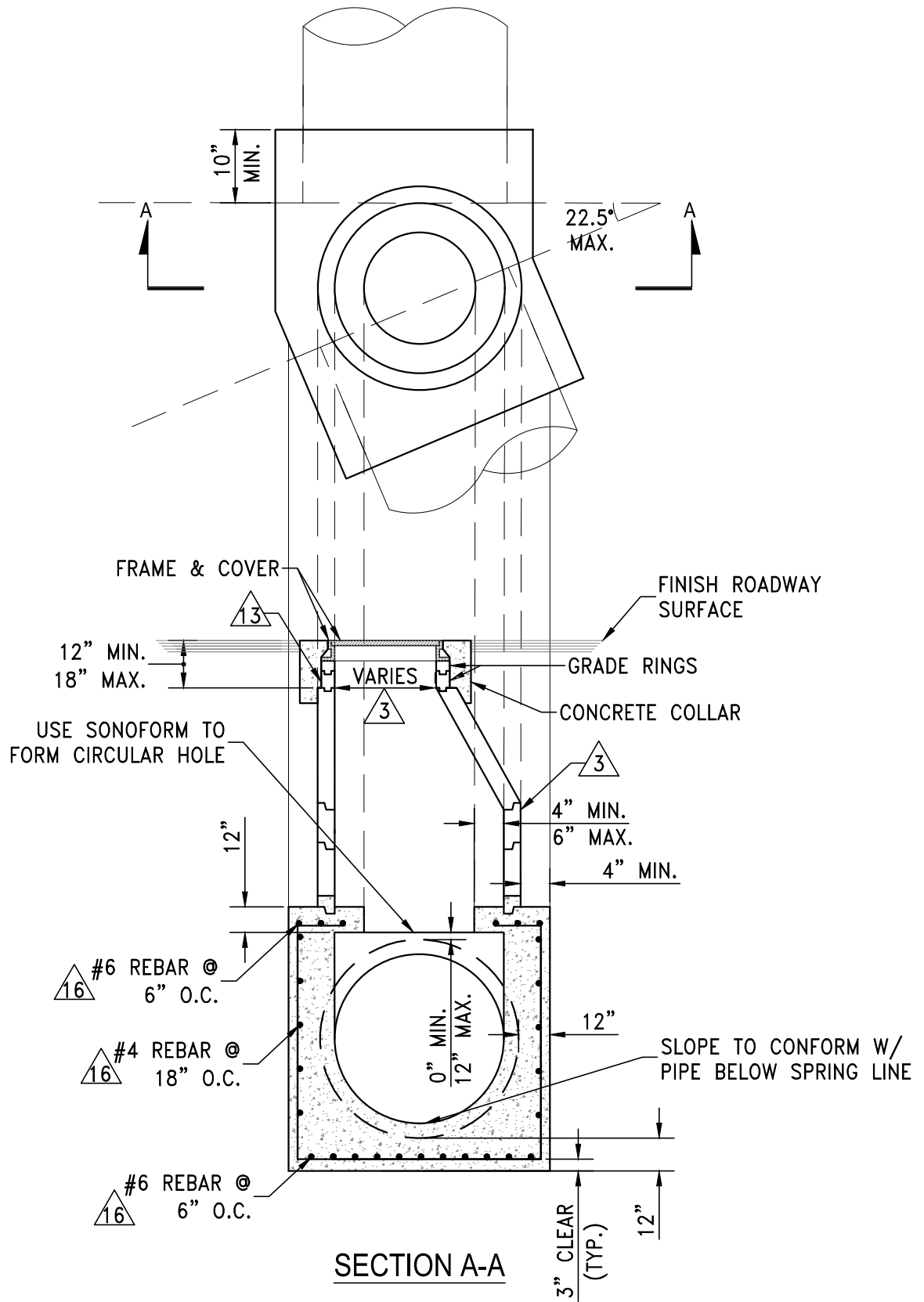

STANDARD DETAILS FOR PUBLIC WORKS CONSTRUCTION

DRAWING No.

MANHOLE TYPE VI - LARGE DIAMETER PIPE

R-210A

APPROVED BY: KK

DATE: 2/2026

NOTES:

1. TYPE VI MANHOLE TO BE UTILIZED FOR PIPE DIAMETERS OF 30" THROUGH 60" AND DEPTHS NOT EXCEEDING 20 FEET.
2. LATERAL PIPE CONFIGURATIONS SHALL NOT EXCEED 12" DIAMETER. ANY CONFIGURATION WITH LARGER DIAMETERS OR GREATER DEPTH SHALL REQUIRE A SEPARATE DETAIL.
3. ALL PRECAST MANHOLE COMPONENTS SHALL CONFORM TO ASTM C-478
- △ 4. FOR 30" PIPE DIAMETERS, MANHOLE COMPONENTS SHALL CONFORM TO TYPE I MANHOLES. FOR ALL OTHER DIAMETERS, MANHOLE COMPONENTS SHALL CONFORM TO TYPE V MANHOLES.
5. PIPE CONNECTION TO MANHOLE SHALL BE WATERTIGHT PER STANDARD DETAILS R-223A, R-223B AND R-223C.
6. MANHOLE BASE SHALL BE PORTLAND CEMENT CONCRETE (P.C.C.) AND SHALL HAVE THE FOLLOWING CHARACTERISTICS: 4000 PSI MIN. COMPRESSIVE STRENGTH AT 28 DAYS. ALL CEMENT CONCRETE SHALL HAVE A COARSE AGGREGATE GRADATIONS CONFORMING TO SIZE No. 67. POLYPROPELENE OR CELLULOSE FIBERS SHALL BE ADDED TO THE P.C.C. AT 1.5 LBS PER CUBIC YARD. MIX DESIGN SHALL CONFORM TO THE REQUIREMENTS OF SECTION 337.10 OF SSPWC. ALL MATERIALS SHALL CONFORM TO SSPWC.
7. MANHOLE MATERIALS AND CONSTRUCTION SHALL CONFORM TO THE REQUIREMENTS OF SECTION 204 "MANHOLES AND CATCH BASINS" OF THE STANDARD SPECIFICATIONS.
8. PRECAST MANHOLE SECTIONS, OTHER THAN GRADE RINGS, SHALL BE JOINED WITH FLEXIBLE GASKET MATERIAL SUCH AS "RAM-NEK" OR EQUAL AS PER MANUFACTURER'S RECOMMENDATIONS.
9. EXCAVATION AND BACKFILL SHALL BE AS SPECIFIED FOR "TRENCH EXCAVATION AND BACKFILL" IN SECTION 305 OF THE STANDARD SPECIFICATIONS.
10. EXCAVATION SHALL BE AS NEARLY VERTICAL AS POSSIBLE (SHEET AND SHORE IF SOIL CONDITIONS REQUIRE) IN EXISTING STREET SECTIONS, ALLEY SECTIONS, AND CONFINED AREAS, SUCH AS LIMITED EASEMENTS OR ADJACENT STRUCTURES.
11. MANHOLE PRECAST SECTION LENGTH SHALL BE ARRANGED TO FIT THE REQUIRED DEPTH.
12. NO LATERALS OR PIPES LESS THAN 8" IN DIAMETER SHALL BE CONNECTED TO THE MANHOLE.
13. ALL MANHOLES SHALL BE WATERTIGHT.
- △ 14. THE USE OF FLAT TOP MANHOLE CONES REQUIRES PRIOR APPROVAL FROM THE CITY ENGINEER.
15. PRIOR TO BACKFILLING, ALL MANHOLES SHALL BE VACUUM TESTED PER ASTM C-1244.
16. NO STEPS, LADDERS, OR OTHER CLIMBING DEVICES SHALL BE INSTALLED IN THE MANHOLE.
- △ 17. REINFORCING STEEL SHALL BE AS SHOWN, WIRED TIGHTLY AT ALL INTERSECTIONS AND EMBEDDED AT LEAST 3" CLEAR, UNLESS OTHERWISE NOTED.
18. WHEN PIPE CONNECTIONS TO EXISTING MANHOLES ARE ALLOWED, THEY SHALL BE MADE BY CORE DRILLING THE MANHOLE AND CONNECTING THE PIPE PENETRATION PER DETAIL R-223A & R-223B.



STANDARD DETAILS FOR PUBLIC WORKS CONSTRUCTION

DRAWING No.

**NOTES - MANHOLE TYPE VI
- LARGE DIAMETER PIPE**

R-210B

APPROVED BY: KK | DATE: 2/2026

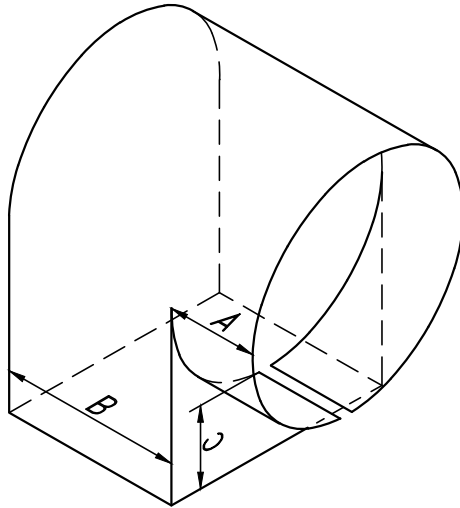

DIMENSIONS			
SIZE	A	B	C
4"	3"	3"	3"
6"	4"	5"	4"
8"	4"	6.5"	4"
10"	4"	8"	4"
12"	5"	10"	4"
15"	6"	10.5"	6.5"

NOTES:

1. ALL CATCH BASINS, PUBLIC OR PRIVATE, SHALL BE PROVIDED WITH A "SUR-TRAP" OIL/WATER SEPARATOR OR APPROVED EQUAL.
2. INSTALL OIL/WATER SEPARATOR WITH THE BOTTOM EDGE PARALLEL TO THE WATER SURFACE AND THE RECTANGULAR OPENING FACING DOWNWARD AND THE CIRCULAR END PLACED INSIDE THE OUTLET PIPE.



STANDARD DETAILS FOR PUBLIC WORKS CONSTRUCTION

DRAWING No.

**CATCH BASIN
OIL / WATER SEPARATOR**

R-213

APPROVED BY: JF

DATE: 1/2013

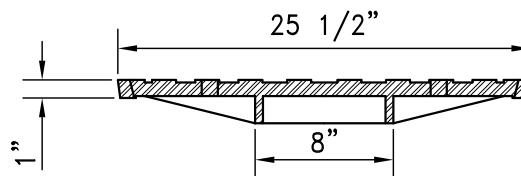
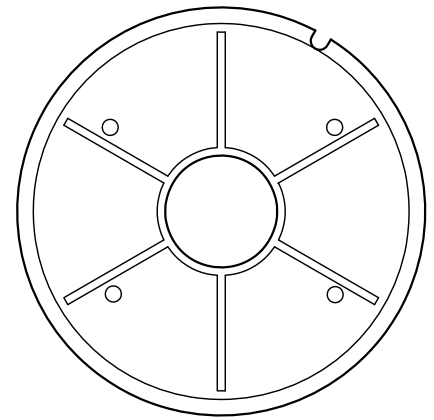
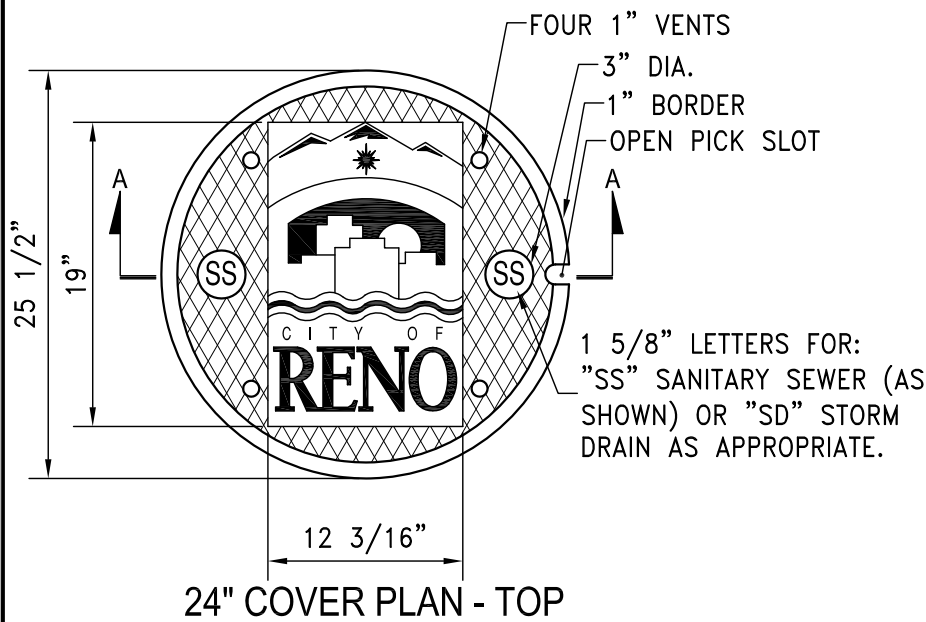

SECTION A-A

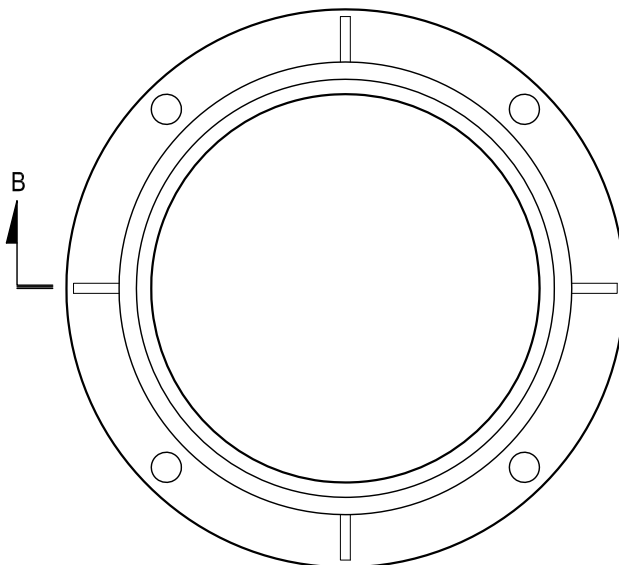

24" MANHOLE FRAME

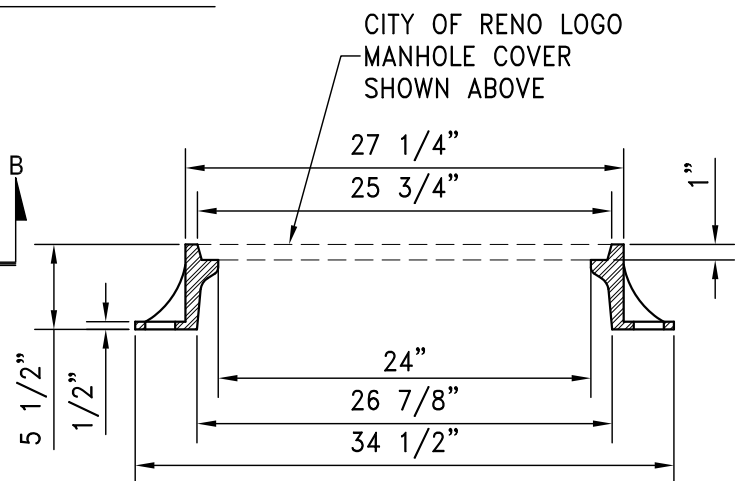

SECTION B-B

24" FRAME AND COVER NOTES:

1. CITY OF RENO LOGO FRAME AND COVERS SHALL BE D&L FOUNDRY A1032 CITY OF RENO FRAME AND COVER OR APPROVED EQUAL. RENO LOGO FRAMES AND COVERS ARE TO BE PLACED ONLY ON CITY OF RENO MAINTAINED FACILITIES. PRIVATE FACILITIES SHALL NOT HAVE THE RENO LOGO ON THE LIDS. THEY SHALL ONLY HAVE THE LETTERS INDICATING "SS" OR "SD".
2. FURNISHED WITH MACHINED HORIZONTAL BEARING SURFACE.
3. CASTINGS SHALL BE CAST GRAY IRON AND MEET THE REQUIREMENTS OF ASTM A-48, CLASS 35B, NO PAINT.



STANDARD DETAILS FOR PUBLIC WORKS CONSTRUCTION

DRAWING No.

**24" MANHOLE
FRAME & COVER**

R-214A

APPROVED BY: JF | DATE: 4/2015

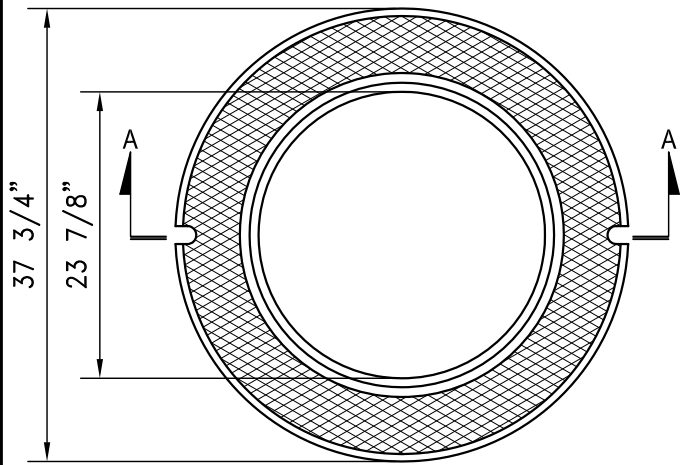

24" COVER ADAPTOR PLAN - TOP

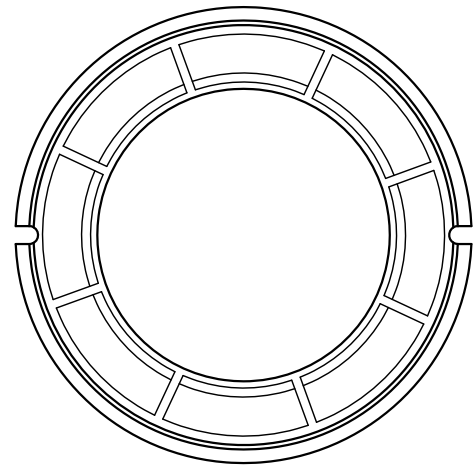

24" COVER ADAPTOR PLAN - BOTTOM

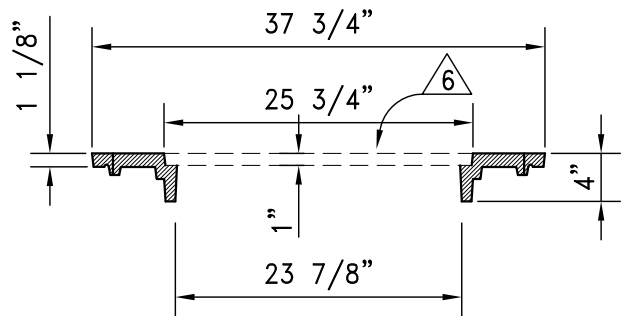

SECTION A-A

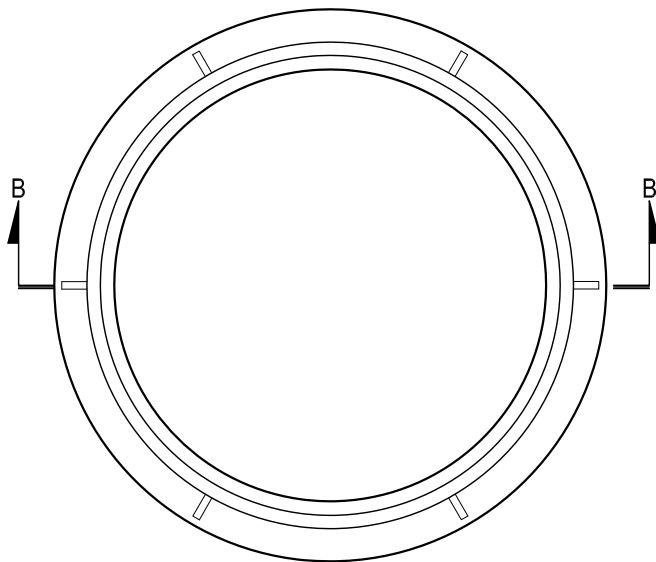

36" MANHOLE FRAME

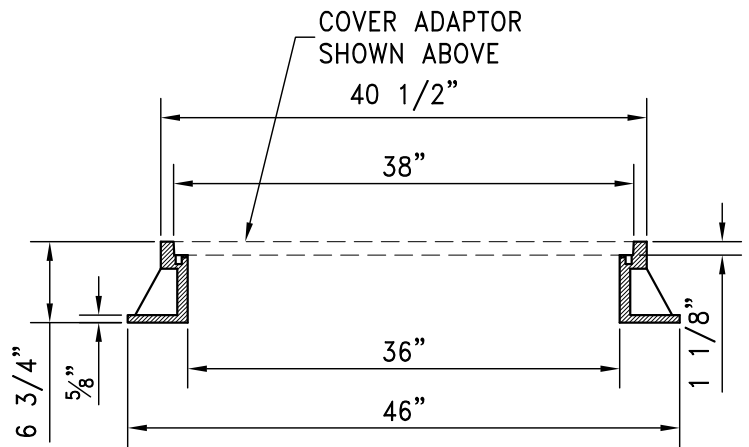

SECTION B-B

36" FRAME AND COVER ADAPTOR NOTES:

1. 24" COVER ADAPTOR SHALL BE D&L FOUNDRY A1462-R5, TO ACCEPT D&L FOUNDRY A1032 CITY OF RENO MANHOLE COVERS AND TO SET IN D&L FOUNDRY A1462 CITY OF RENO FRAME OR APPROVED EQUAL.
2. 36" MANHOLE FRAME SHALL BE D&L FOUNDRY A1462 CITY OF RENO FRAME OR APPROVED EQUAL.
3. CASTINGS SHALL BE CAST GRAY IRON, AND MEET THE REQUIREMENTS OF ASTM A-48, CLASS 35B, NO PAINT.
4. FURNISHED WITH MACHINED HORIZONTAL BEARING SURFACE.
5. MANHOLE COVER ADAPTOR SHALL BE FREE OF HOOKS OR PROTRUSIONS THAT MAY HINDER REMOVAL.
6. FOR A1032 CITY OF RENO LOGO COVER, SEE 24" MANHOLE FRAME AND COVER DETAIL (COVER ONLY).



STANDARD DETAILS FOR PUBLIC WORKS CONSTRUCTION

DRAWING No.

**36" MANHOLE FRAME
WITH 24" COVER ADAPTOR**

R-214B

APPROVED BY: JF

DATE: 3/2014

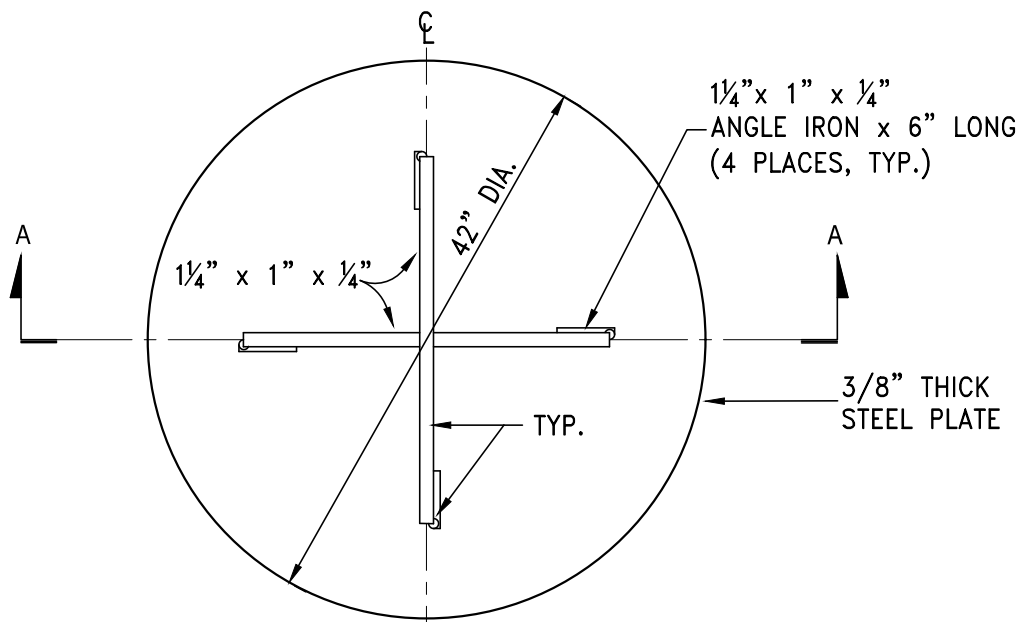

TEMPORARY COVER

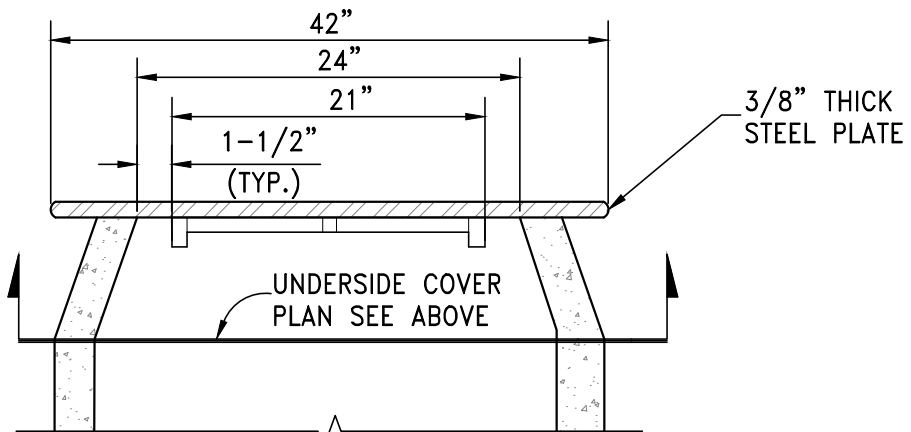

SECTION A-A

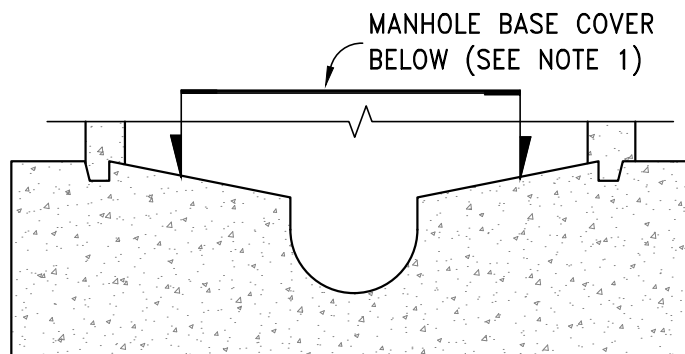

NOTES:

1. INSTALL TEMPORARY COVER WITH CONE INSTALLATION WHEN INSTALLING NEW MANHOLE OR PRIOR TO REMOVING EXISTING FRAME & COVER AND GRADE RINGS TO ADJUST TO FINISH GRADE. INSTALL COVER OVER MANHOLE BASE TO PREVENT DEBRIS FROM ENTERING SEWER SYSTEM. THE MANHOLE BASE COVER SHALL BE IN PLACE PRIOR TO PERFORMING ANY ADJUSTMENTS OR GROUTING AND SHALL REMAIN IN PLACE WHILE ADJUSTMENTS OR GROUTING ARE BEING PERFORMED. REMOVE BASE COVER UPON ADJUSTMENT APPROVAL BY CITY OF RENO.



STANDARD DETAILS FOR PUBLIC WORKS CONSTRUCTION

**TEMPORARY MANHOLE
COVER**

DRAWING No.

R-214C

APPROVED BY: JF | DATE: 1/2013

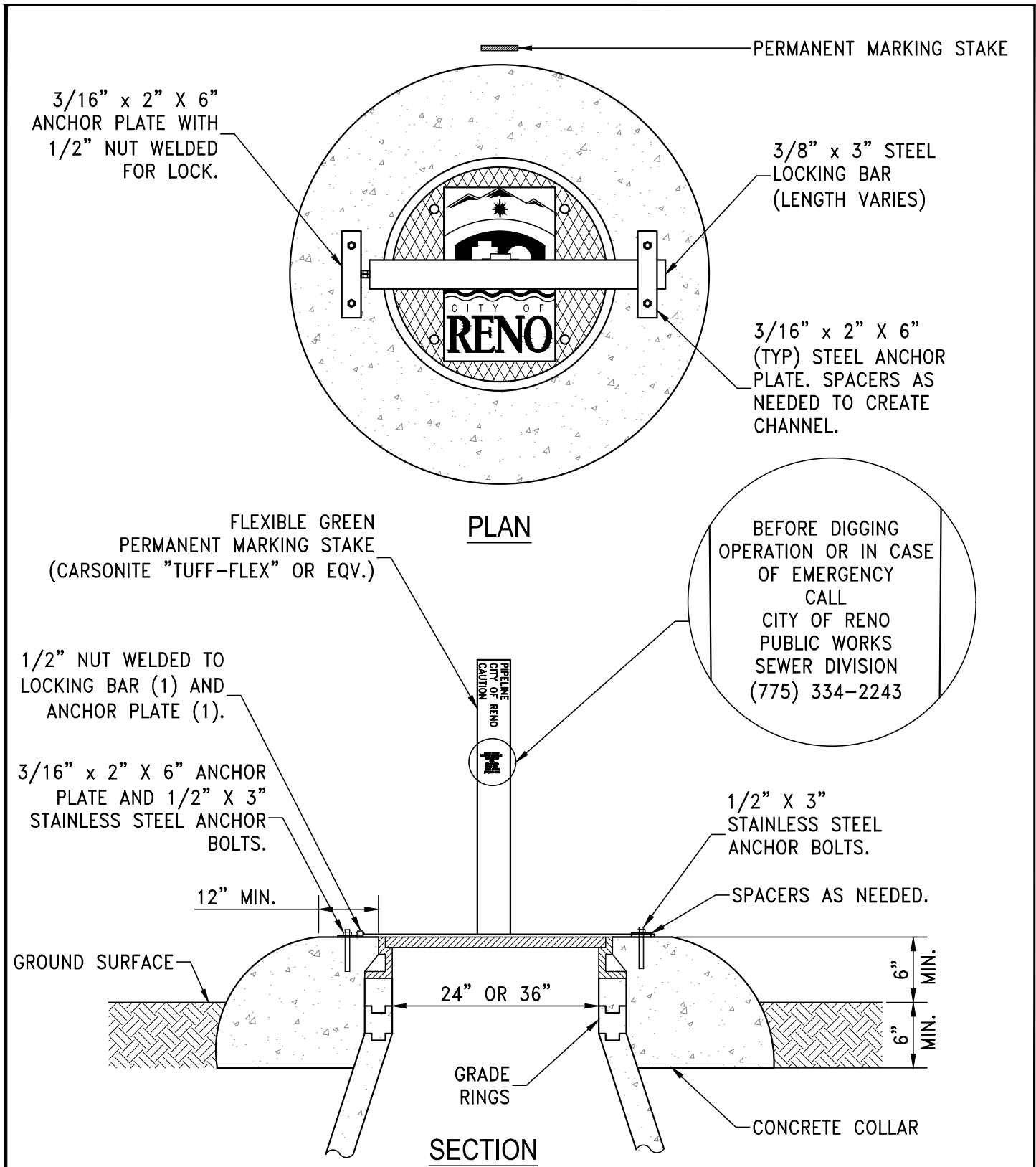

FLEXIBLE GREEN PERMANENT MARKING STAKE (CARSONITE "TUFF-FLEX" OR EQV.)

BEFORE DIGGING OPERATION OR IN CASE OF EMERGENCY CALL CITY OF RENO PUBLIC WORKS SEWER DIVISION (775) 334-2243

1/2" NUT WELDED TO LOCKING BAR (1) AND ANCHOR PLATE (1).

3/16" x 2" x 6" ANCHOR PLATE AND 1/2" x 3" STAINLESS STEEL ANCHOR BOLTS.

1/2" x 3" STAINLESS STEEL ANCHOR BOLTS.

SPACERS AS NEEDED.

12" MIN.

24" OR 36"

6" MIN.

6" MIN.

NOTES:

1. LOCK TO BE SUPPLIED BY CITY OF RENO-SEWER LINES MAINTENANCE.
2. ALL NOTES FROM "MANHOLE COLLAR" DETAIL R-218A SHALL APPLY.



STANDARD DETAILS FOR PUBLIC WORKS CONSTRUCTION

DRAWING No.

MANHOLE COLLAR EASEMENT AREAS

R-218B

APPROVED BY: KK | DATE: 1/2023

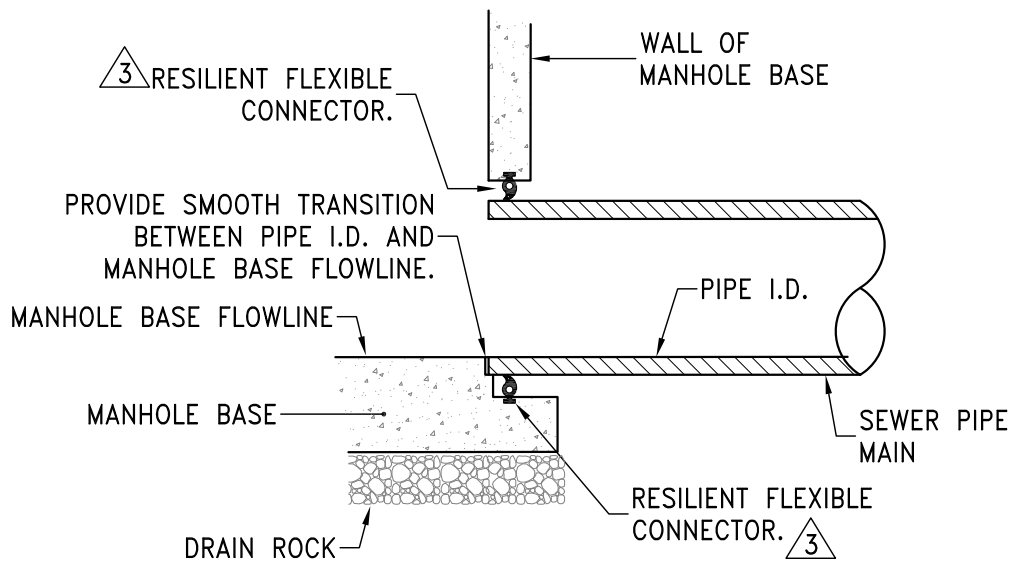
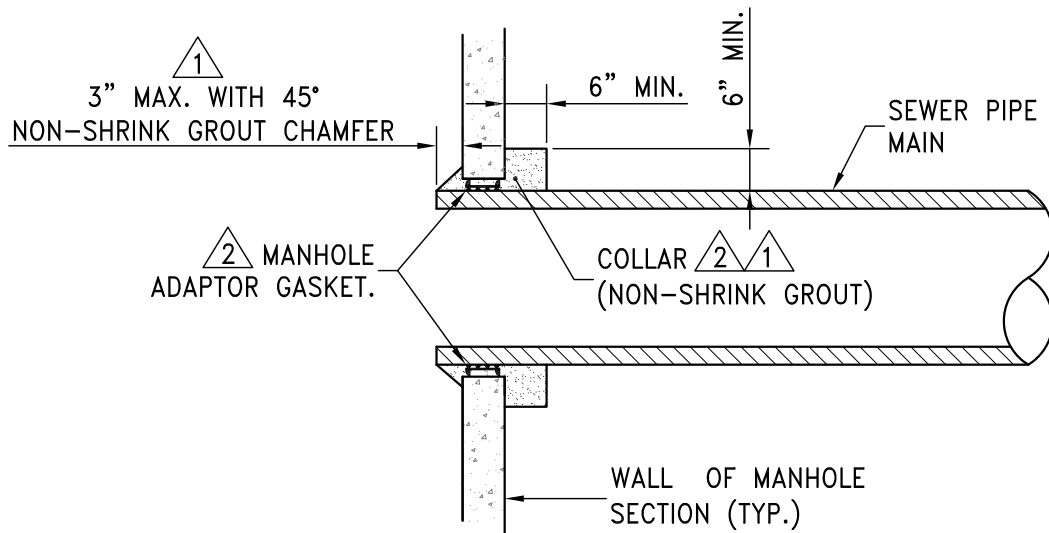

SECTION

NOTES:

1. NON-SHRINK GROUT SHALL HAVE THE FOLLOWING CHARACTERISTICS: 3000 PSI MIN. COMPRESSIVE STRENGTH AT 28 DAYS, MIN. 6 SACKS OF CEMENT PER CUBIC YARD AND SLUMP AT 1 TO 4 INCHES. ALL MATERIAL SHALL CONFORM TO STANDARD SPECIFICATIONS OF PUBLIC WORKS CONSTRUCTION (SSPWC) SECTION 202.
2. SANITARY SEWER PIPE CONNECTION TO MANHOLE SECTIONS (DROP MANHOLES) REQUIRE AN AGENCY-APPROVED FORM OF SEAL OR WATER STOP TO PROVIDE A WATERTIGHT CONNECTION. UTILIZE A ROMAC STYLE "LCT" MANHOLE ADAPTOR GASKET OR APPROVED EQUAL IN CONJUNCTION WITH NON-SHRINK GROUT.
3. SANITARY SEWER PIPE CONNECTION TO MANHOLE BASE SHALL REQUIRE A RESILIENT FLEXIBLE CONNECTOR INSTALLED IN ACCORDANCE WITH STANDARD DETAIL R-223C.
4. ALL PIPE OPENINGS TO NEW MANHOLES MUST BE EITHER CAST-IN-PLACE OR PRE-FORMED AND PIPE OPENINGS TO EXISTING MANHOLES MUST BE CORE DRILLED.



STANDARD DETAILS FOR PUBLIC WORKS CONSTRUCTION

DRAWING No.

**SANITARY SEWER PIPE
TO MANHOLE CONNECTION**

R-223A

APPROVED BY: JF DATE: 4/2014

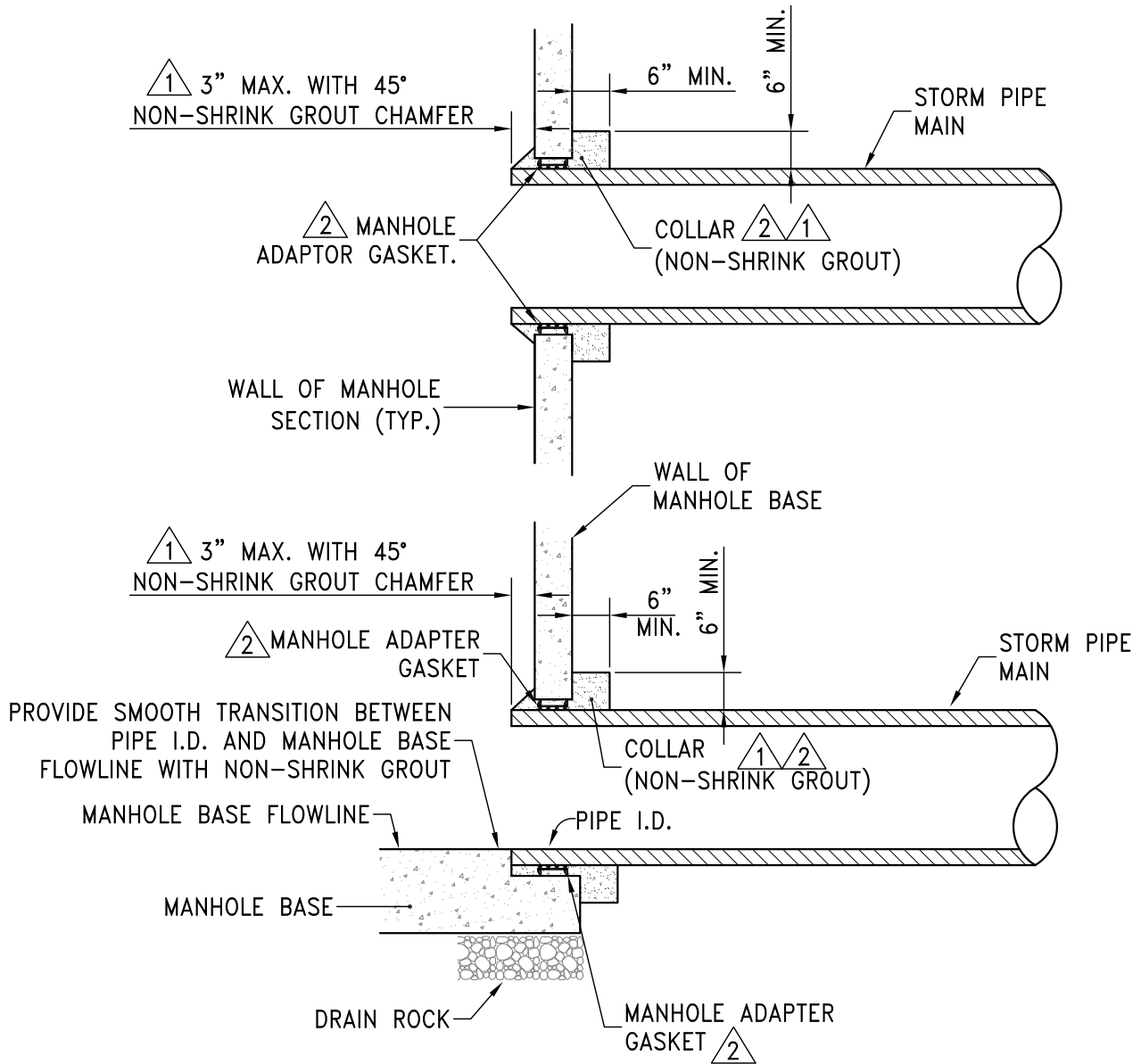

NOTE:

1. NON-SHRINK GROUT SHALL HAVE THE FOLLOWING CHARACTERISTICS: 3000 PSI MIN. COMPRESSIVE STRENGTH AT 28 DAYS, MIN. 6 SACKS OF CEMENT PER CUBIC YARD AND SLUMP AT 1 TO 4 INCHES. ALL MATERIAL SHALL CONFORM TO SSPWC SECTION 202.
2. STORM DRAIN PIPE CONNECTIONS TO MANHOLE BASES AND SECTIONS REQUIRE AN AGENCY-APPROVED FORM OF SEAL OR WATER STOP AND IS REQUIRED ON ALL STORM DRAIN INSTALLATIONS TO PROVIDE A WATERTIGHT CONNECTION. UTILIZE A ROMAC STYLE "LCT" MANHOLE ADAPTER GASKET OR APPROVED EQUAL IN CONJUNCTION WITH THE NON-SHRINK GROUT.
3. A RESILIENT FLEXIBLE CONNECTOR INSTALLED IN ACCORDANCE WITH STANDARD DETAIL R-223C MAY BE USED TO SATISFY THE REQUIREMENTS OF NOTE 2 ABOVE.
4. ALL PIPE OPENINGS TO NEW MANHOLES MUST BE EITHER CAST-IN-PLACE OR PRE-FORMED AND PIPE OPENINGS TO EXISTING MANHOLES MUST BE CORE DRILLED.



STANDARD DETAILS FOR PUBLIC WORKS CONSTRUCTION

DRAWING No.

**STORM DRAIN PIPE TO
MANHOLE CONNECTION**

R-223B

APPROVED BY: JF | DATE: 4/2014

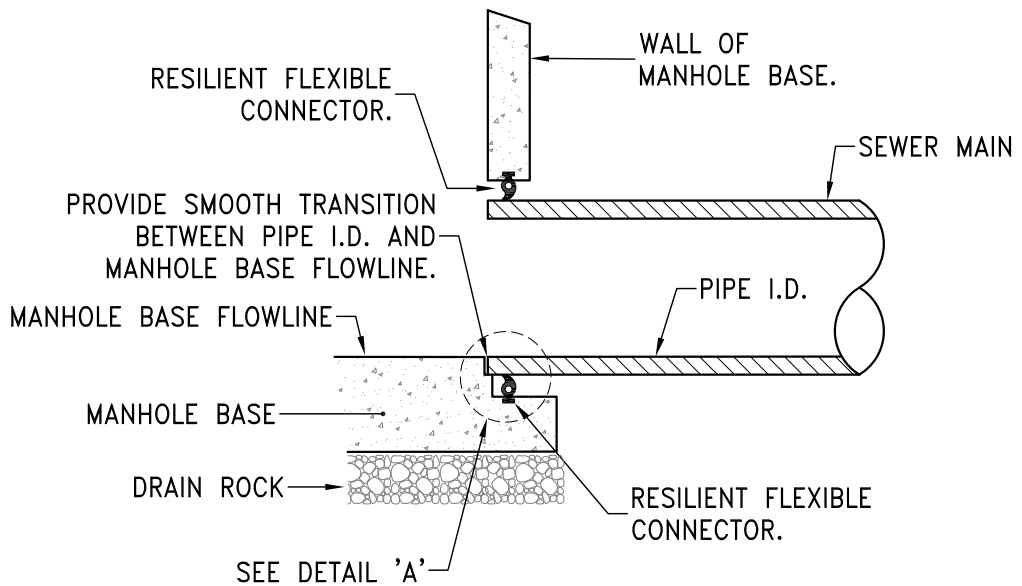

SECTION

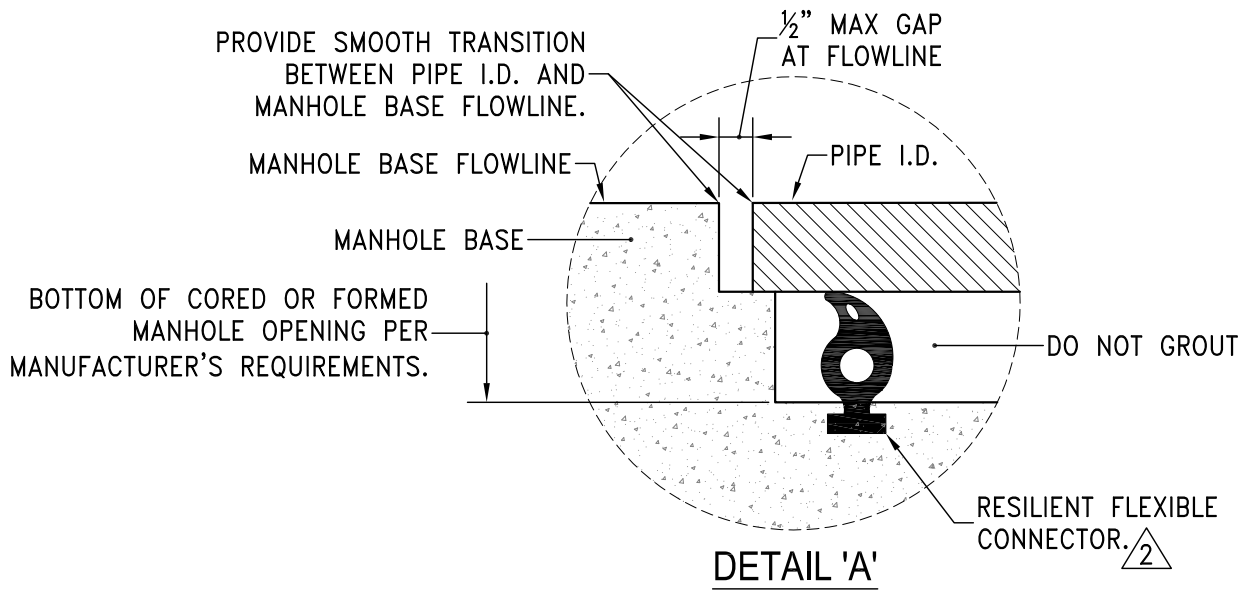

NOTES:

1. A SEAL OR WATER STOP IS REQUIRED ON ALL SANITARY SEWER INSTALLATIONS AND IN OTHER APPLICATIONS AS REQUIRED BY THE CITY TO PROVIDE A WATERTIGHT CONNECTION.
2. A RESILIENT FLEXIBLE CONNECTOR PER ASTM C 923-89 SHALL BE USED AT THE MANHOLE/PIPE CONNECTION TO SATISFY THE REQUIREMENTS OF NOTE 1. FOR PRE-CAST CONCRETE STRUCTURES, THE RESILIENT FLEXIBLE CONNECTOR SHALL BE AN "A-LOK" TYPE PIPE-TO-MANHOLE CONNECTOR OR APPROVED EQUAL. FOR CAST-IN-PLACE STRUCTURES, THE RESILIENT FLEXIBLE CONNECTOR SHALL BE A "KOR-N-SEAL I - TOGGLE KORBAND" TYPE PIPE-TO-MANHOLE CONNECTOR OR APPROVED EQUAL.
3. THE INTERIOR MANHOLE CONNECTION SHALL HAVE A SMOOTH TRANSITION BETWEEN PIPE I.D. AND MANHOLE BASE FLOWLINE. NO GROUT OR CONCRETE SHALL BE PLACED AROUND THE RESILIENT FLEXIBLE CONNECTOR.



STANDARD DETAILS FOR PUBLIC WORKS CONSTRUCTION

DRAWING No.

**RESILIENT FLEXIBLE
CONNECTOR**

R-223C

APPROVED BY: JF

DATE: 4/2014

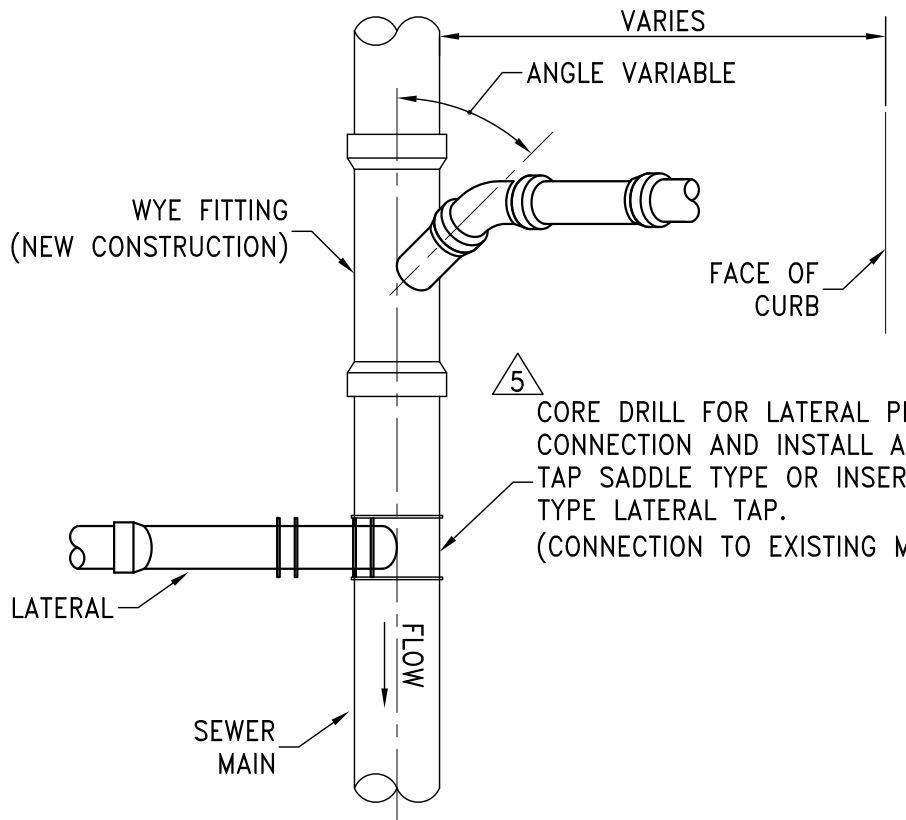

PLAN

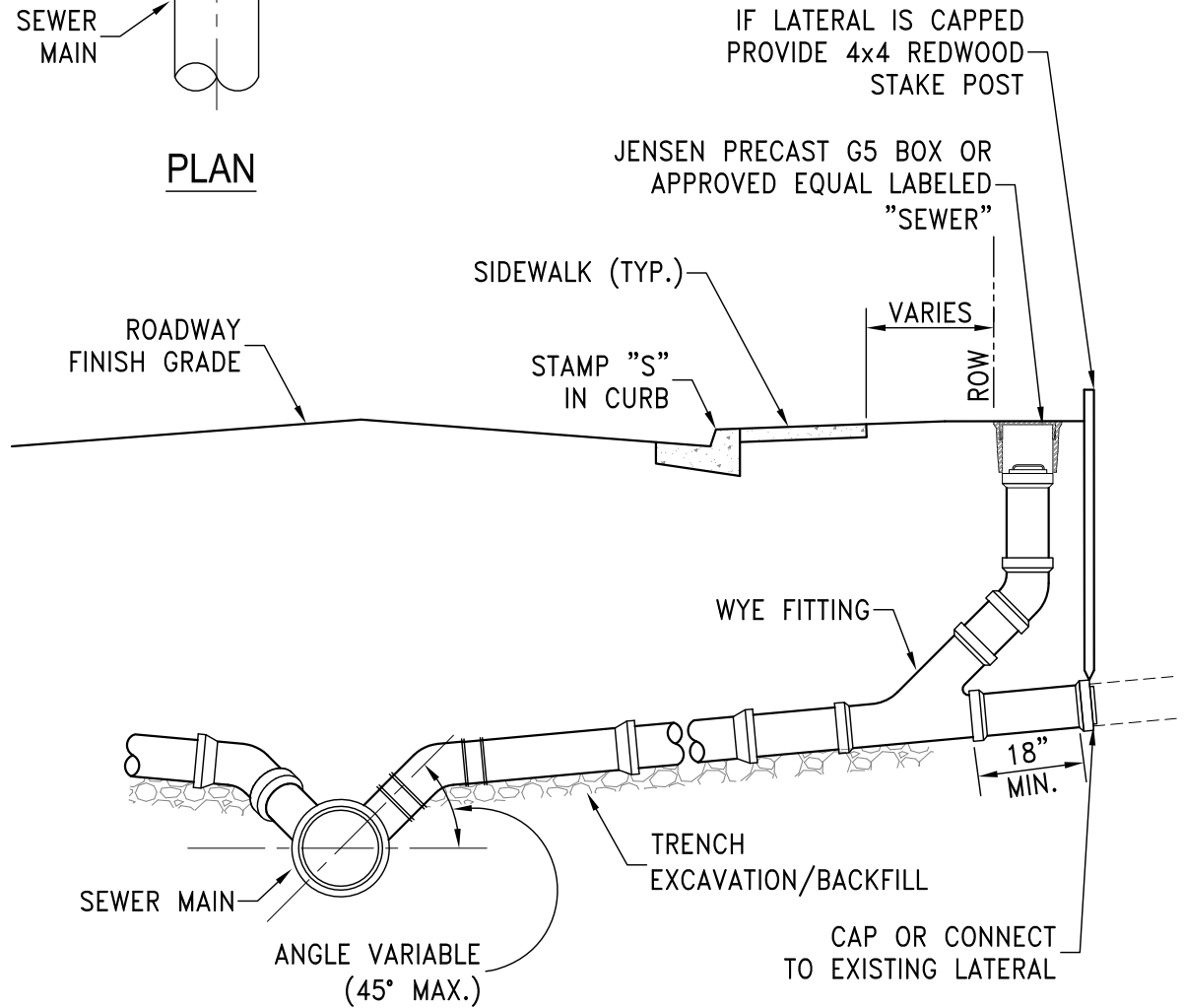

SECTION



STANDARD DETAILS FOR PUBLIC WORKS CONSTRUCTION

DRAWING No.

**SANITARY SEWER
LATERAL**

R-224A

APPROVED BY: JF | DATE: 1/2013

NOTES:

1. SEWER LATERALS SHALL HAVE A MINIMUM PIPE DIAMETER OF 4-INCHES.
2. ALL PLASTIC PIPE USED FOR SEWER SERVICE LATERAL CONSTRUCTION SHALL BE SOLID WALL AND SHALL MEET THE REQUIREMENTS OF D-2412, HAVE A MINIMUM STIFFNESS OF 46 PSI AS DEFINED BY THE REQUIREMENTS OF ASTM D-3034.
3. SERVICE LATERALS SHALL HAVE A MINIMUM SLOPE OF 1/4-INCH PER FOOT UNLESS OTHERWISE APPROVED BY THE CITY ENGINEER.
4. SEWER LATERALS SHALL HAVE A MINIMUM COVER OF 36-INCHES IN THE PUBLIC RIGHT-OF-WAY AND IN EASEMENTS UNLESS OTHERWISE APPROVED BY THE CITY ENGINEER. THE DEFINITION OF "COVER" IS THE DISTANCE FROM THE TOP OF PIPE TO FINISHED GRADE.
5.  USE OF SEWER SERVICE TAP SADDLE CONNECTIONS SHALL NOT BE ALLOWED FOR NEW SEWER MAIN CONSTRUCTION. WHEN A TAP SADDLE CONNECTION IS TO BE USED ON AN EXISTING SEWER MAIN, IT SHALL BE A WYE SADDLE AND BE INSTALLED PER DETAIL R-224C.
6. SEWER LATERALS SHALL HAVE A CLEANOUT INSTALLED IMMEDIATELY UPSTREAM OF THE POINT WHERE THE SERVICE LATERAL EXITS THE PUBLIC RIGHT-OF-WAY OR EASEMENT. A G5 BOX CLEARLY MARKED "SEWER" SHALL BE INSTALLED OVER THE TOP OF THE CLEANOUT RISER CAP PIPE.
7. SEWER LATERALS SHALL NOT BE CONNECTED DIRECTLY TO OR WITHIN 5-FEET OF A MANHOLE STRUCTURE.
8. EXISTING SEWER LATERALS SHALL BE CUT BACK TO SOUND MATERIAL FOR COUPLING. PLACE 6-INCH THICK CONCRETE PAD UNDER CONNECTION.
9. SEWER LATERAL CONNECTION SHALL BE STABILIZED WITH APPROVED MATERIAL FOLLOWING INSTALLATION. CONNECTION TO CITY SEWER MAIN MUST BE INSPECTED BY THE CITY PRIOR TO BACKFILL.
10. NO LATERAL CONNECTIONS SHALL BE MADE DIRECTLY TO A SANITARY SEWER "INTERCEPTOR" UNLESS APPROVED BY THE UTILITY SERVICES DIRECTOR.
11. SEWER LATERALS SHALL NOT BE CONNECTED TO A SEWER MAIN UNLESS THE CONNECTION POINT IS BETWEEN TWO MANHOLE STRUCTURES.
12. EACH INDIVIDUAL PARCEL SHALL HAVE A MINIMUM OF ONE SEWER LATERAL. TWO OR MORE PARCELS SHALL NOT SHARE ONE SEWER LATERAL.
13. SANITARY SEWER LATERAL IDENTIFICATION AND LOCATING REQUIREMENTS SHALL BE PER RENO MUNICIPAL CODE 12.18 (RMC 12.18).
14. DISCONTINUANCE OF USE OF AN EXISTING SEWER LATERAL REQUIRES ABANDONMENT OF THE LATERAL. CUT, REMOVE 1-FOOT OF EXISTING LATERAL AND CAP BOTH ENDS OF THE EXISTING SEWER LATERAL TO BE ABANDONED WITHIN 6-INCHES OF THE SEWER MAIN. ABANDONMENT MUST BE INSPECTED BY CITY PRIOR TO BACKFILL.
15. PROPERTY OWNER SHALL BE RESPONSIBLE FOR OPERATION, MAINTENANCE AND REPAIR OF THE SEWER LATERAL WITHIN THE PUBLIC RIGHT-OF-WAY PER RENO MUNICIPAL CODE.



STANDARD DETAILS FOR PUBLIC WORKS CONSTRUCTION

DRAWING No.

**NOTES - SANITARY SEWER
LATERAL**

R-224B

APPROVED BY: KK | DATE: 9/2022

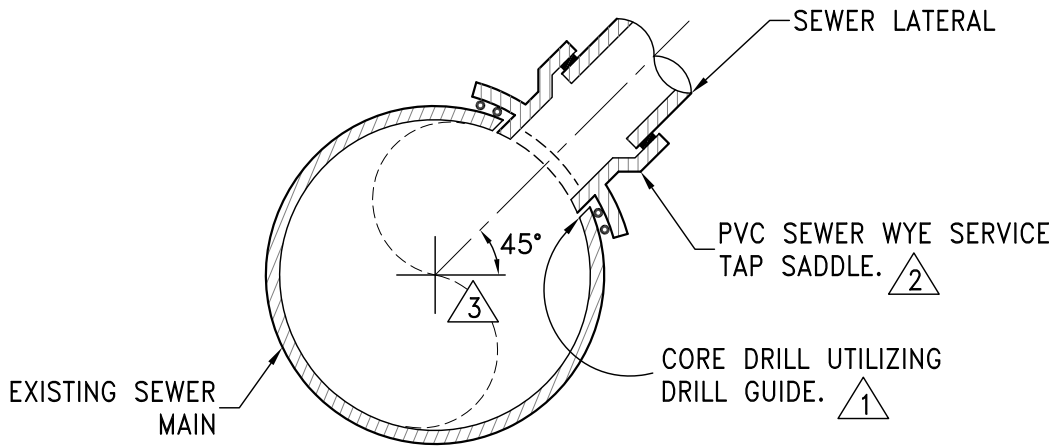

SECTION A-A

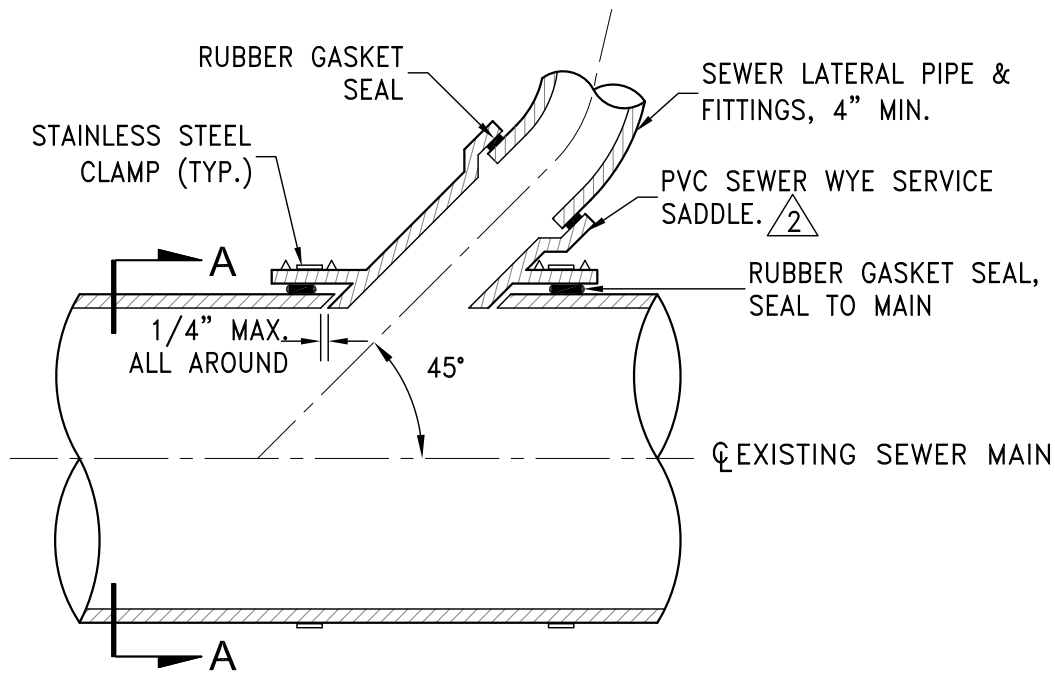

SIDE VIEW

NOTES:

1. EXISTING SEWER MAINS SHALL BE CORE DRILLED UTILIZING A DRILL GUIDE FOR A WYE SADDLE AND A CORE DRILL WITH A LENGTH EXCEEDING THE LATERAL DIAMETER, INSERT-A-DRILL IDY75 & EXTRA LONG HOLE SAW OR APPROVED EQUAL. DIAMOND CORE BITS SHALL BE USED ON NON-PVC MAINS.
2. SERVICE TAP SADDLES SHALL BE PVC SEWER WYE SADDLES. A ROMAC STYLE "CB" SEWER SADDLE OR APPROVED EQUAL MAY BE USED ON EXISTING SEWER MAINS ONLY WHEN MAIN IS NOT PVC.
3. SADDLES SHALL BE INSTALLED AT 45 DEGREES TO MAIN AS SHOWN IN SECTION A-A. IN NO CASE SHALL A LATERAL CONNECTING TO THE EXISTING SEWER MAIN BE LOCATED DIRECTLY ON TOP OF THE PIPE, NOR SHALL IT MATCH THE FLOWLINE OF THE PIPE.



STANDARD DETAILS FOR PUBLIC WORKS CONSTRUCTION

DRAWING No.

**SANITARY SEWER
TAP SADDLE**

R-224C

APPROVED BY: JF | DATE: 1/2013

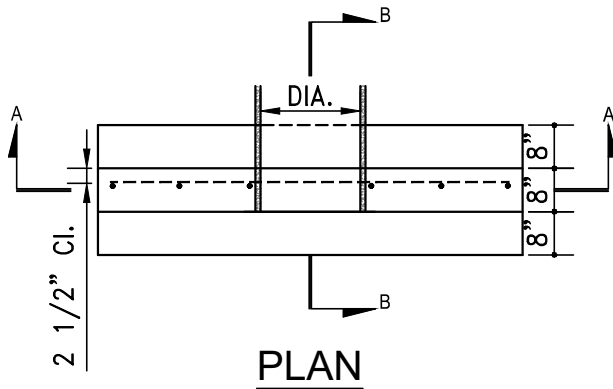

PIPE DIA.	X	Y	L	H
12"	0'-10"	1'-2"	4'-0"	3'-0"
15"	0'-10 1/4"	1'-2 1/4"	5'-0"	3'-3 1/2"
18"	0'-10 1/2"	1'-2 1/2"	5'-9"	3'-7"
21"	0'-10 3/4"	1'-2 3/4"	6'-6"	3'-10 1/2"
24"	0'-11"	1'-3"	7'-3"	4'-2"
27"	0'-11"	1'-3"	8'-0"	4'-5"
30"	0'-11 1/2"	1'-3 1/2"	9'-0"	4'-9"
33"	0'-11 3/4"	1'-3 3/4"	4'-0"	5'-1/2"
36"	1'-0"	1'-4"	10'-6"	5'-4"

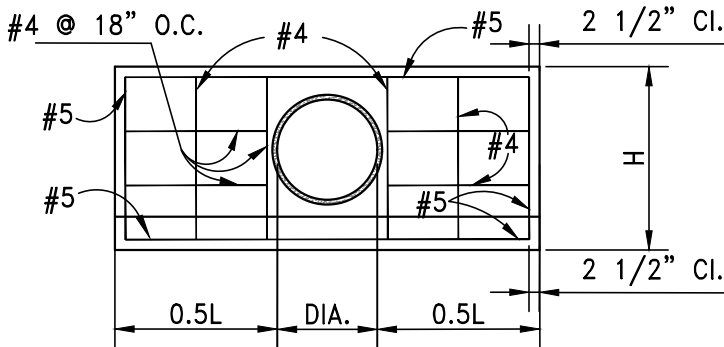

SECTION A-A

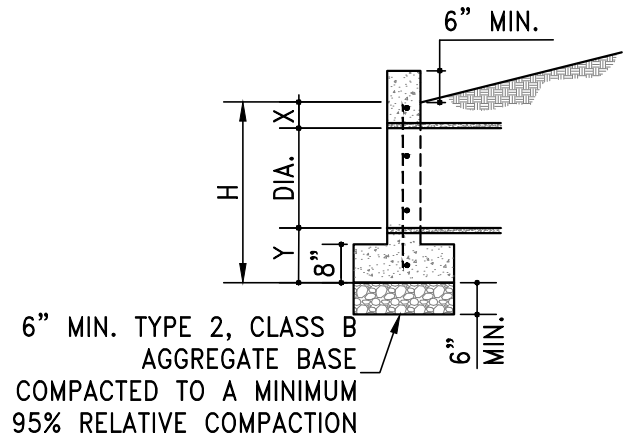

SECTION B-B

NOTES:

1. PORTLAND CEMENT CONCRETE (P.C.C.) SHALL BE 4000 PSI MIN. COMPRESSIVE STRENGTH AT 28 DAYS. ALL CEMENT CONCRETE SHALL HAVE A COARSE AGGREGATE GRADATION CONFORMING TO SIZE No. 67. POLYPROPYLENE OR CELLULOSE FIBERS SHALL BE ADDED TO THE P.C.C. AT 1.5 LBS PER CUBIC YARD. MIX DESIGN SHALL CONFORM TO THE REQUIREMENTS OF SECTION 337.10 OF SSPWC. ALL MATERIALS SHALL CONFORM TO SSPWC.
2. REINFORCING STEEL SHALL BE DEFORMED BARS WITH MAXIMUM SPACING OF 18" SET 2 1/2" CLEAR OF SURFACE OF CONCRETE EXCEPT AS NOTED. BAR ENDS SHALL BE KEPT 1 1/2" CLEAR OF SURFACE OF CONCRETE. REINFORCING BARS MAY BE CUT AND BENT IN FIELD.
3. FOOTINGS SHOWN ARE OF MINIMUM DEPTH AND SHALL BE EXTENDED IF SOIL IS UNSUITABLE OR LIABLE TO SCOUR.
4. CULVERT PIPES TO BE SET ON A SKEW SHALL BE MITERED WHEN HEADWALLS ARE CONSTRUCTED.
5. DIMENSIONS X, Y, L, AND H TO REMAIN CONSTANT REGARDLESS OF MINOR VARIATIONS IN WALL THICKNESS DUE TO CLASS OF PIPE USED.
6. SKEWED HEADWALLS, HEADWALLS FOR DOUBLE PIPES OR FOR PIPES GREATER THAN 36" SHALL BE DESIGNED BY A STRUCTURAL ENGINEER AND SUBMITTED TO THE CITY FOR APPROVAL.



STANDARD DETAILS FOR PUBLIC WORKS CONSTRUCTION

CULVERT HEADWALL

DRAWING No.

R-225

APPROVED BY: KK

DATE: 1/2023

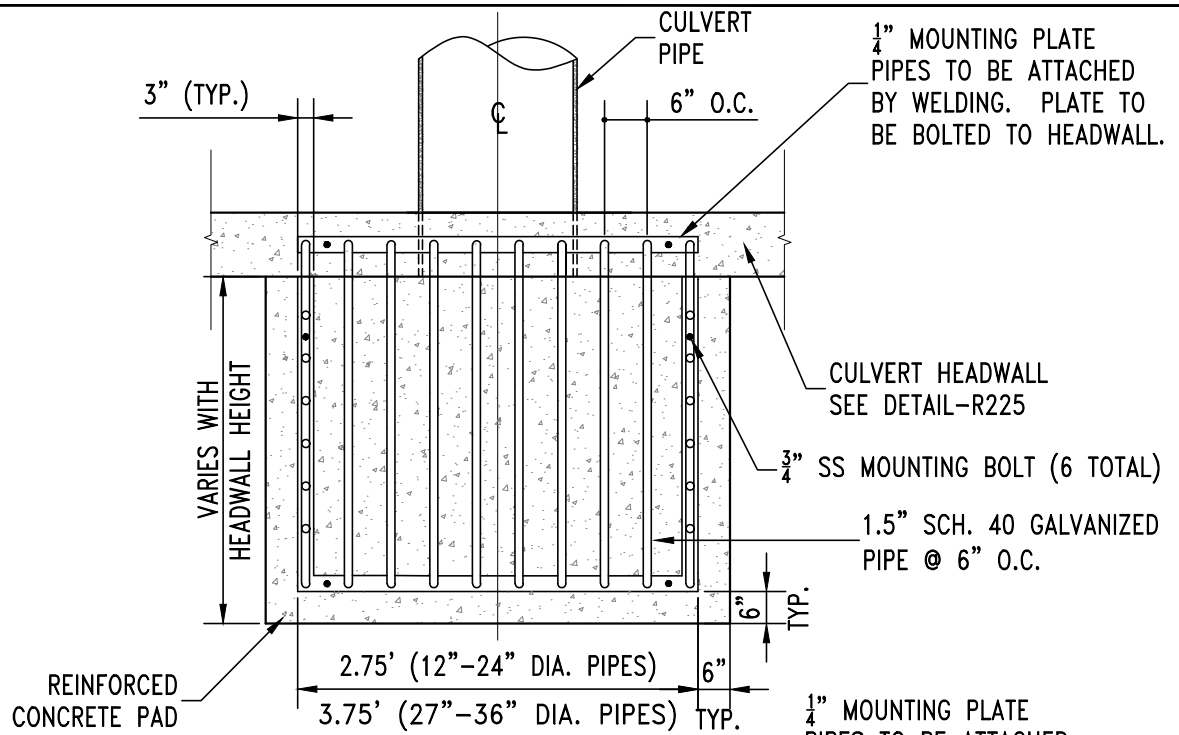

PLAN

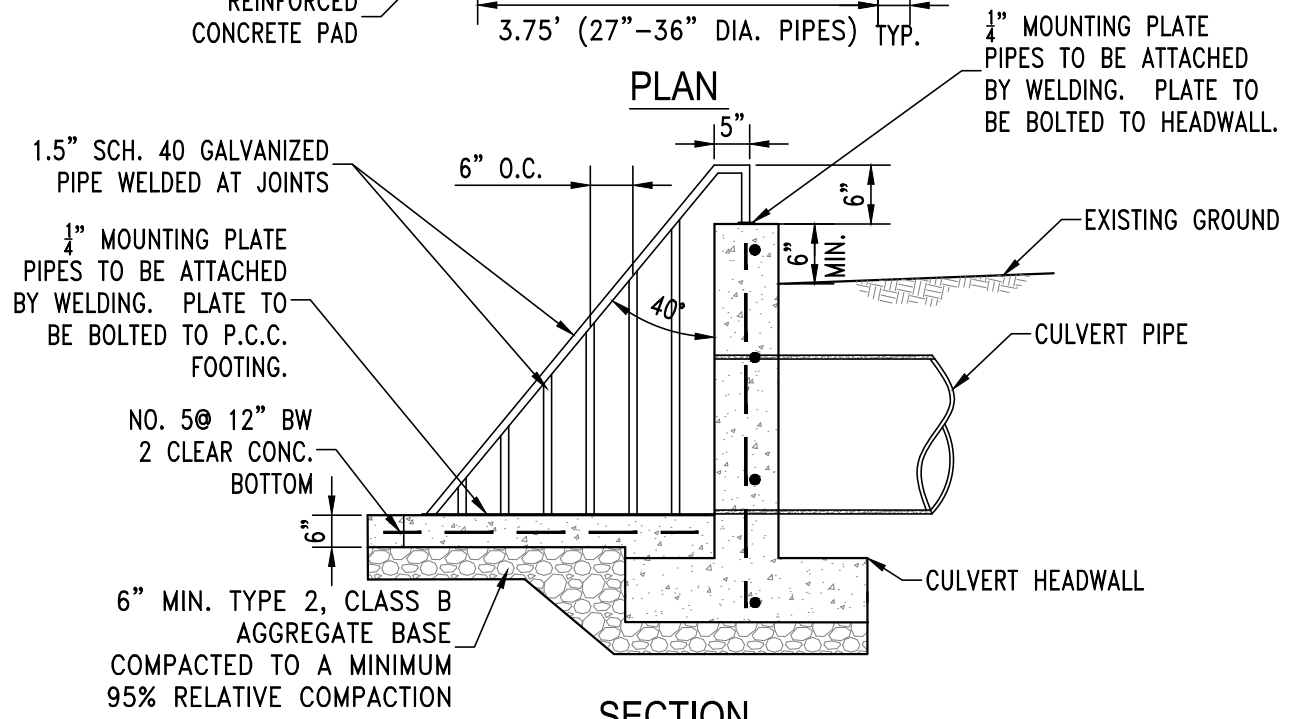

SECTION

NOTES:

1. PORTLAND CEMENT CONCRETE (P.C.C.) SHALL BE 4000 PSI MIN. COMPRESSIVE STRENGTH AT 28 DAYS. ALL CEMENT CONCRETE SHALL HAVE A COARSE AGGREGATE GRADATION CONFORMING TO SIZE No. 67. POLYPROPYLENE OR CELLULOSE FIBERS SHALL BE ADDED TO THE P.C.C. AT 1.5 LBS PER CUBIC YARD. MIX DESIGN SHALL CONFORM TO THE REQUIREMENTS OF SECTION 337.10 OF SSPWC. ALL MATERIALS SHALL CONFORM TO SSPWC.
2. ALL METAL PARTS SHALL BE GALVANIZED AFTER WELDING.
3. ENGINEERS SHALL SUBMIT DETAILED PLANS FOR PIPES DIAMETERS GREATER THAN 36" OR WHEN REQUIRED BY THE CITY ENGINEER.



STANDARD DETAILS FOR PUBLIC WORKS CONSTRUCTION

DRAWING No.

HEADWALL TRASH RACK

R-226

APPROVED BY: KK

DATE: 1/2023

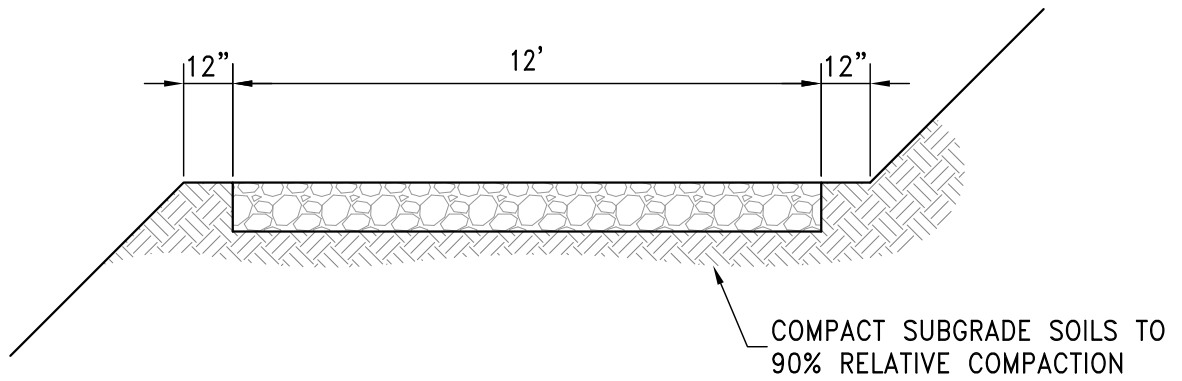

ACCESS TO SD INLETS 24" DIA. & LARGER

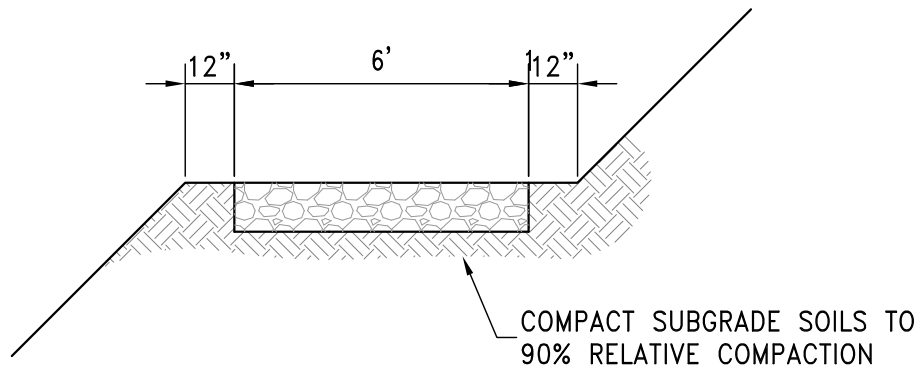

ACCESS TO SD INLETS SMALLER THAN 24" DIA. & ALL OUTLETS

NOTES:

1. 12' WIDE 6"-8" Ø COBBLE STONE LAID TO BE A "DRIVEABLE" SURFACE TO THE SATISFACTION OF THE CITY WITH HAMMERHEAD VEHICLE TURNAROUNDS.
2. 6' WIDE 6"-8" Ø COBBLE STONE LAID TO BE A "DRIVEABLE" SURFACE TO THE SATISFACTION OF THE CITY.



STANDARD DETAILS FOR PUBLIC WORKS CONSTRUCTION

DRAWING No.

**STORM DRAIN ACCESS ROADS
(FOR HILLSIDE DEVELOPMENT)**

R-227

APPROVED BY: JF | DATE: 1/2013

FIRE HYDRANT COLOR SCHEDULE

RENO

ALL HYDRANTS TO BE FACTORY ENAMELED SAFETY RED.

SPARKS

PUBLIC HYDRANTS TO BE FACTORY ENAMELED SAFETY YELLOW.
PRIVATE HYDRANTS TO BE FACTORY ENAMELED SAFETY RED.

WASHOE COUNTY

PUBLIC HYDRANTS TO BE FACTORY ENAMELED SAFETY RED.
PRIVATE HYDRANTS TO BE FACTORY ENAMELED SAFETY RED WITH HIGH REFLECTIVE WHITE TOP.

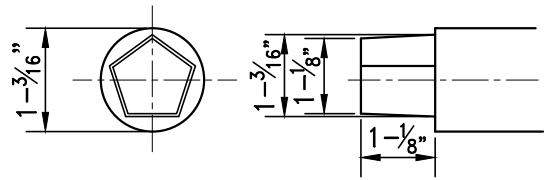

OPERATING NUT - PENTAGON

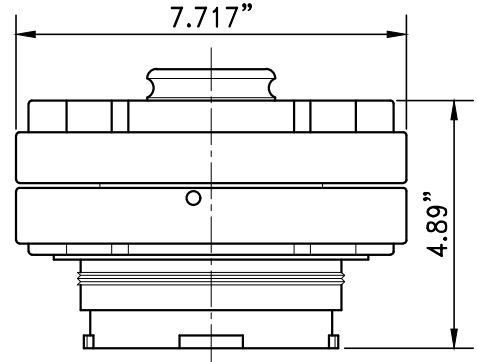

INTEGRAL 5" STORZ PUMPER NOZZLE ASSEMBLY

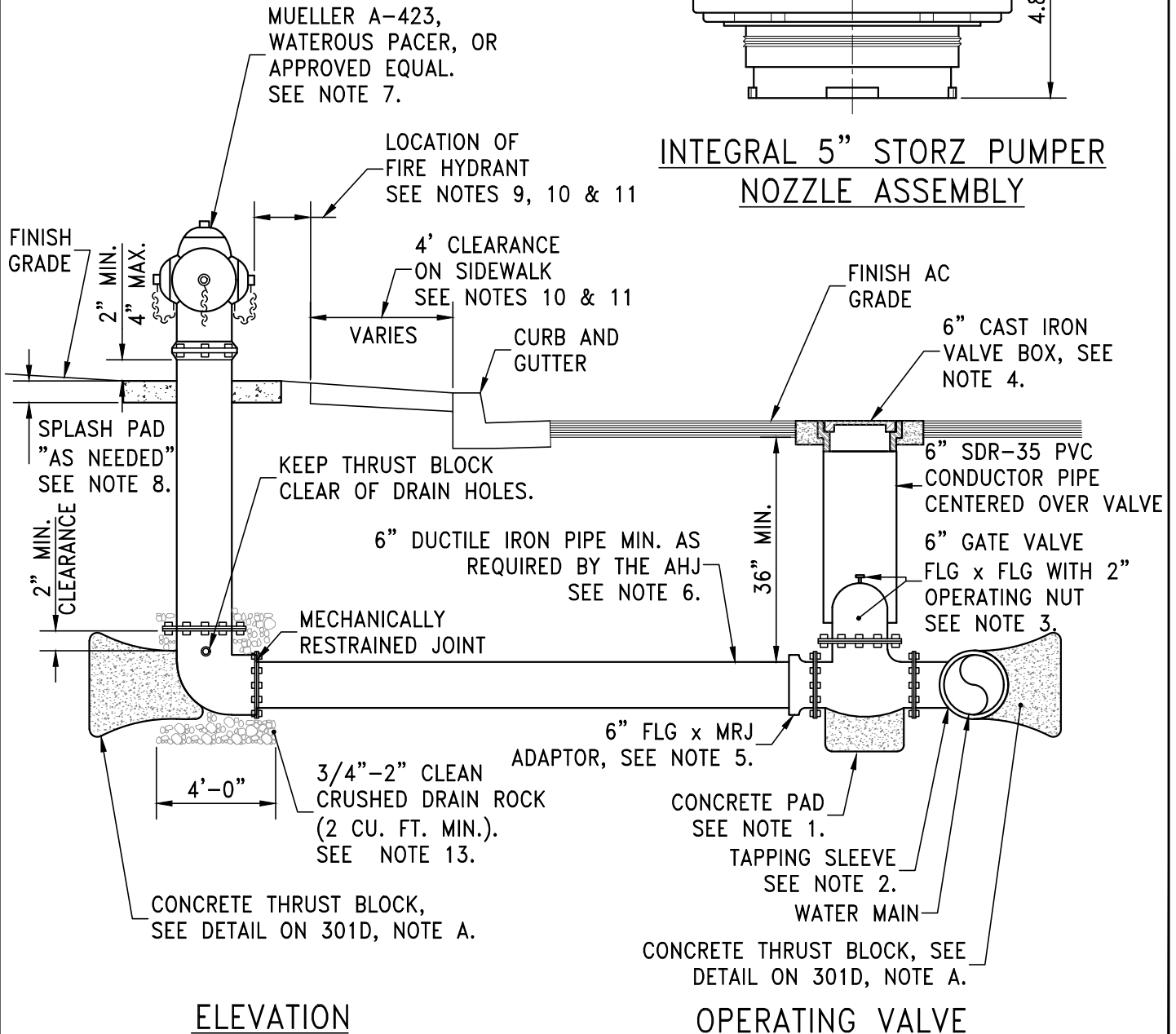

ELEVATION

OPERATING VALVE

STANDARD DETAILS FOR PUBLIC WORKS CONSTRUCTION

AHJ

DRAWING No.

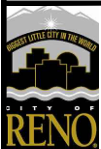

FIRE HYDRANT

RENO

R-301A

SPARKS

S-301A

W/C

W-23A

DATE: 1/2020

NOTES:

1. PORTLAND CEMENT CONCRETE (P.C.C.) SHALL HAVE THE FOLLOWING CHARACTERISTICS: 4000 PSI MIN. COMPRESSIVE STRENGTH AT 28 DAYS, MIN. 6 SACKS OF CEMENT PER CUBIC YARD WITH MAX. WATER-CEMENT RATIO OF 0.45, AIR ENTRAINMENT 6% ±1.5%, SLUMP AT 1 TO 4 INCHES. MIX DESIGN SHALL CONFORM TO THE REQUIREMENTS OF SECTION 337 OF STANDARD SPECIFICATIONS FOR PUBLIC WORKS CONSTRUCTION (SSPWC), AS ADOPTED BY AUTHORITY HAVING JURISDICTION (AHJ). CEMENT SHALL BE TYPE II. ALL CEMENT CONCRETE SHALL HAVE A COARSE AGGREGATE GRADATION CONFORMING TO SIZE No. 67. POLYPROPYLENE OR CELLULOSE FIBERS SHALL BE ADDED TO THE P.C.C. AT 1.5 LBS. PER CUBIC YARD. ALL MATERIALS SHALL CONFORM TO SSPWC, AS ADOPTED BY AHJ.

2. TAPPING SLEEVE

HOT-TAP TAPPING SLEEVES SHALL BE FULL-CIRCLE ASTM A 240, TYPE 304 STAINLESS STEEL WITH FULL CIRCUMFERENCE GASKETS THROUGHOUT SLEEVE LENGTH WITH AWWA C207 CLASS D ANSI 150 LB. DRILLING ASTM A 240, TYPE 304 STAINLESS STEEL FLANGE. TYPE 304 STAINLESS STEEL STUD BOLTS, HEAVY HEX NUTS, AND WASHERS SHALL BE INCLUDED. HEAVY HEX NUTS AND STUD BOLTS SHALL BE COATED TO PREVENT GALLING. TYPE 304 STAINLESS STEEL TEST PLUG SHALL BE INCLUDED WITH THREADS COATED TO PREVENT GALLING. TAPPING SLEEVE SHALL BE RATED FOR A TEST PRESSURE OF 300 PSI AND WORKING PRESSURE OF 200 PSI. TAPPING SLEEVE SHALL BE ROMAC STYLE "SST" STAINLESS STEEL TAPPING SLEEVE AS MANUFACTURED BY ROMAC INDUSTRIES, INC.; SMITH-BLAIR 663 STAINLESS STEEL FLANGE TAPPING SLEEVE AS MANUFACTURED BY SMITH-BLAIR, INC.; OR EQUAL.

ALL WATER MAIN SHUT DOWNS AND/OR INSTALLATION OF TAPPING SLEEVES SHALL BE COORDINATED WITH THE WATER PURVEYOR IN THE AREA AND CONFORM TO THEIR REQUIREMENTS. TAPPING SLEEVES ARE TO BE USED ONLY FOR EXISTING INSTALLATIONS.

3. GATE VALVE

GATE VALVE SHALL BE 6-INCH, FLG X FLG AND SHALL MEET AWWA C515, DUCTILE IRON BODY, NON-RISING STEM, RESILIENT-SEATED VALVE. GATE VALVE SHALL BE EQUIPPED WITH A 2-INCH OPERATING NUT FOR BURIED SERVICE. GATE VALVE SHALL BE FUSION EPOXY LINED AND COATED. ALL VALVES FOR BURIED SERVICE SHALL BE POLYETHYLENE ENCASED PER AWWA C105. GATE VALVE SHALL BE A MUELLER A-2361 RESILIENT WEDGE GATE VALVE; AMERICAN AVK COMPANY SERIES 65 AWWA C515 DUCTILE IRON GATE VALVE; OR APPROVED EQUAL.

4. 6" VALVE BOX SHALL BE D&L #8044 & #8056 OR APPROVED EQUAL. CASTINGS SHALL BE CAST IRON GRAY AND MEET THE REQUIREMENTS OF ASTM A48-74, CLASS 30B, NO PAINT.

5. 6-INCH FLG X MRJ ADAPTOR

6-INCH FLG X MRJ ADAPTOR SHALL BE DUCTILE IRON AND MEET THE REQUIREMENTS OF AWWA STANDARDS C110/C153 AND C104. ALL FITTINGS SHALL BE POLYETHYLENE ENCASED PER AWWA C105. ADAPTOR SHALL BE ASPHALTIC COATED WITH CEMENT-MORTAR LINING PER AWWA C110/C153 AND C104.

6. 6-INCH MINIMUM DUCTILE IRON LATERAL PIPE

ALL DUCTILE IRON PIPE SHALL MEET THE REQUIREMENTS OF AWWA STANDARDS C151, C104, AND C111 WITH PRESSURE CLASS 350, STANDARD CEMENT LINING, BITUMINOUS COATING, AND SHALL BE NSF-61 CERTIFIED. ALL DUCTILE IRON PIPE SHALL BE POLYETHYLENE ENCASED WITH THICKNESS OF 4 MIL AND BE BLACK IN COLOR. MATERIAL SHALL BE HIGH-DENSITY, CROSS-LAMINATED FILM CONFORMING TO SECTION 4.1.3 OF AWWA STANDARD C105. TUBE SIZE SHALL BE AS LISTED IN TABLE 1 OF SAME STANDARD. DUCTILE IRON PIPE SHALL BE EQUIPPED WITH TYTON TYPE BELL AND SPIGOT JOINTS. DUCTILE IRON PIPE SHALL BE TYTON DUCTILE IRON PIPE AS MANUFACTURED BY U.S. PIPE, GRIFFIN TYTON JOINT DUCTILE IRON PIPE AS MANUFACTURED BY GRIFFIN PIPE PRODUCTS CO., INC., OR APPROVED EQUAL. EXCEPTIONS FOR PRIVATE INSTALLATION UPON APPROVAL FROM AHJ.

STANDARD DETAILS FOR PUBLIC WORKS CONSTRUCTION

AHJ

DRAWING No.



NOTES - FIRE
HYDRANT

RENO

R-301B

SPARKS

S-301B

W/C



W-23B

DATE: 1/2020

NOTES CONT:

7. MUELLER A-423 OR AMERICAN WATEROUS PACER WB67-250 WITH 5-1/4" VALVE OPENING OR FIRE DEPARTMENT APPROVED EQUAL. RISER SHALL BE 4 FT OR 5 FT AND RISER TYPE SHALL BE SAME AS THE FIRE HYDRANT MANUFACTURER. HYDRANTS MUST BE FACTORY PAINTED TO BE ACCEPTED. ALL HYDRANTS SHALL HAVE TWO 2-1/2" HOSE NOZZLES AND ONE FACTORY INSTALLED INTEGRAL 5" STORZ PUMPER NOZZLE ASSEMBLY.
8. IF PROPOSED HYDRANT LOCATION IS WITHIN PARKWAY OR LANDSCAPE WHERE NO CONCRETE EXISTS, PLACE 36" DIAMETER ROUND OR 36" x 36" SQUARE, 4" THICK REINFORCED CONCRETE SPLASH PAD AS REQUIRED BY THE AHJ. NO FENCES, LANDSCAPE FEATURES, OR OTHER OBSTRUCTIONS SHALL BE ALLOWED WITHIN 3- FEET OF ANY PORTION OF A FIRE HYDRANT. CLEARANCE IS MEASURED FROM ALL OBSTRUCTIONS TO THE NEAREST POINT ON THE FIRE HYDRANT. ANTICIPATED PLANT GROWTH TO BE CONSIDERED IN DESIGN AND INSTALLATION.
9. FIRE HYDRANTS SHALL BE INSPECTED BY AHJ INSPECTOR. INSPECTIONS SHALL BE SCHEDULED A MINIMUM OF TWO BUSINESS DAYS PRIOR AND INSPECTIONS SHALL BE PERFORMED DURING REGULAR BUSINESS HOURS. CONTACT AHJ FIRE PREVENTION BUREAU TO SCHEDULE INSPECTIONS.
10. FIRE HYDRANTS SHALL BE PLACED WITHIN THE RIGHT-OF-WAY OR EASEMENT GRANTED OUTSIDE THE RIGHT-OF-WAY. FIRE HYDRANT PLACED WITHIN PEDESTRIAN WALKWAY AND/OR SIDEWALKS SHALL PROVIDE FOR A MINIMUM OF 4 FT CLEARANCE IN ACCORDANCE WITH PUBLIC RIGHT-OF-WAY ACCESSIBILITY GUIDELINES (PROWAG).
11. AHJ APPROVAL IS REQUIRED FOR HYDRANT LOCATION WHERE NO SIDEWALK EXISTS BEHIND CURB OR WHERE A LANDSCAPE STRIP IS BETWEEN THE CURB AND THE SIDEWALK.
12. FIRE HYDRANTS SHALL BE TESTED BY THE AHJ PRIOR TO COMBUSTIBLES BEING BROUGHT ON SITE.
13. FOR TRENCH EXCAVATION/BACKFILL SPECIFICATIONS SEE DETAIL BELOW. ALL DRAIN ROCK SHALL BE PLACED PRIOR TO INSPECTION AND BACKFILL.

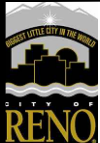
TRENCH EXCAVATION/BACKFILL	
AHJ	DETAIL #
RENO	R-122
SPARKS	S-117
WASHOE COUNTY	W-22

STANDARD DETAILS FOR PUBLIC WORKS CONSTRUCTION		AHJ	DRAWING No.	
 	<h1>NOTES - FIRE HYDRANT</h1>		RENO	R-301C
			SPARKS	S-301C
			W/C	W-23C
DATE: 1/2020				

THRUST BLOCK DETAILS & NOTES

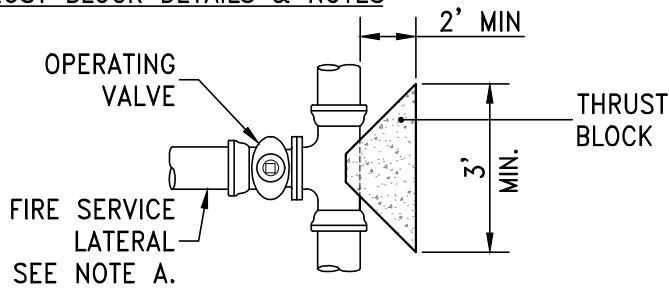

THRUST BLOCK AT OPERATING VALVE - PLAN VIEW

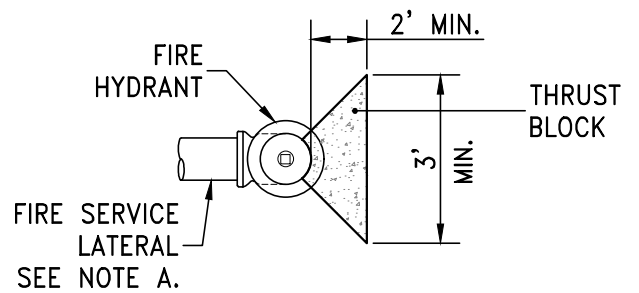

THRUST BLOCK AT FIRE HYDRANT - PLAN VIEW

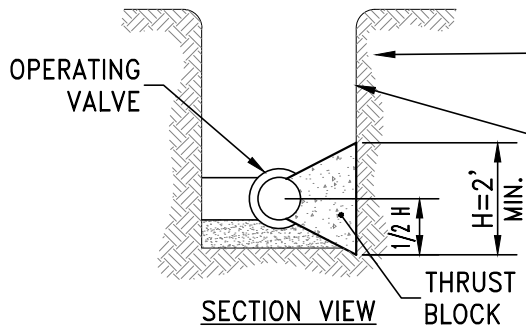

THRUST BLOCK NOTES

- A. THRUST BLOCK SIZE ASSUMES MAXIMUM 6" DIAMETER FIRE HYDRANT SERVICE. THRUST BLOCKS FOR LARGER SERVICES REQUIRE APPROVAL OF AHJ.
- B. THE THRUST BLOCK DESIGN SHALL BE BASED ON THE FORCE RESISTING CAPACITY OF THE NATIVE SOILS AS STATED IN THE SOILS EVALUATION REPORT SPECIFIC TO THE PROJECT SITE. THE CALCULATIONS SHOWN WITH THE TRUST BLOCK DESIGN AND SIZING TABLE SHALL BE BASED ON THE REQUIREMENTS OF THE MOST CURRENT NFPA 24, ARTICLE 10.8.2 REQUIREMENTS. THE SOIL EVALUATION REPORT OR A SINGLE PAGE, STAMPED SUMMARY SHALL BE SUBMITTED WITH THE PROJECT PLANS.
- C. THRUST BLOCKS SHALL BE Poured AGAINST UNDISTURBED SOIL. IN CASES WHERE THIS IS NOT PRACTICAL, BACKFILL AREA BEHIND WHERE THRUST BLOCK WILL BE PLACED WITH AGGREGATE BASE COMPACTED TO 95% RELATIVE COMPACTION, CUT-BACK COMPACTED AGGREGATE BASE TO EXPOSE A FIRM SURFACE, THEN PLACE THRUST BLOCK.

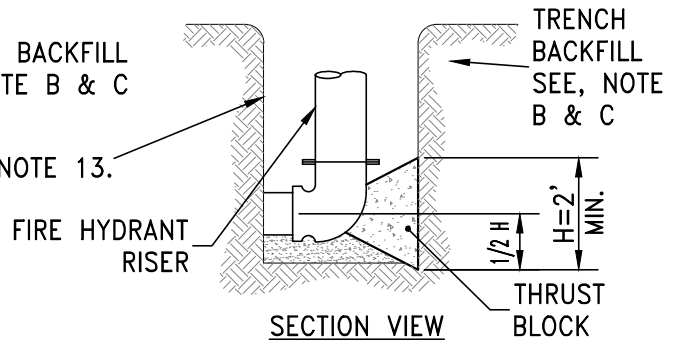

STANDARD DETAILS FOR PUBLIC WORKS CONSTRUCTION

AHJ	DRAWING No.
RENO	R-301D
SPARKS	S-301D
W/C	W-23D
DATE: 1/2020	

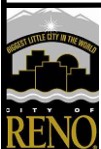

NOTES - FIRE HYDRANT

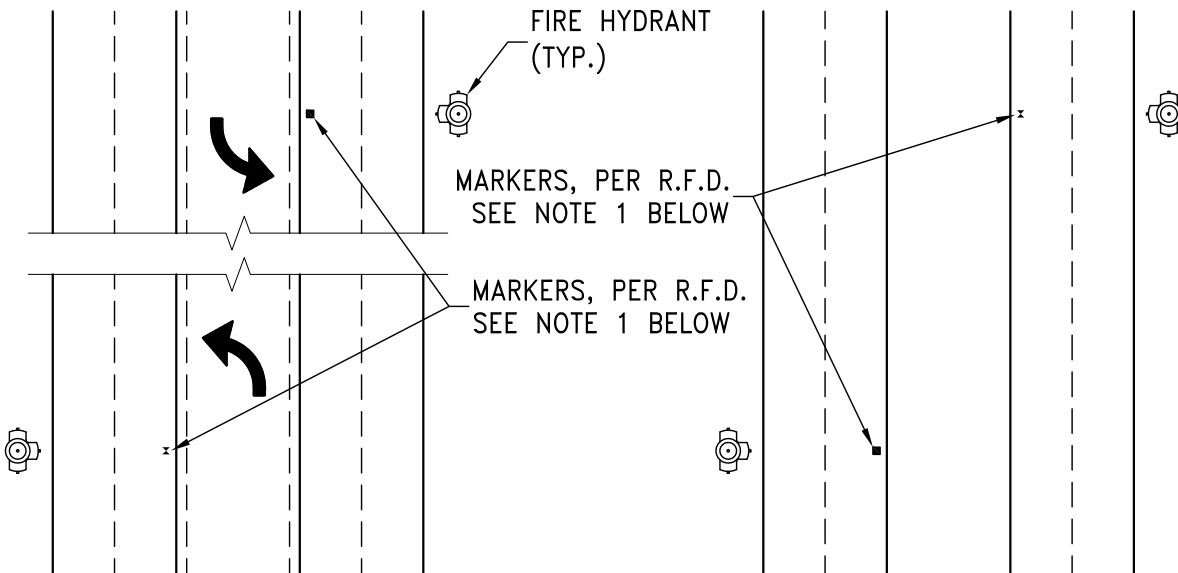

STREETS WITH CENTER TURN LANE, MARKER IS PLACED 8" TO 12" OFF YELLOW SOLID LINE, TO THE SIDE OF THE HYDRANT.

STREETS WITH CENTER PLANTER OR CONCRETE ISLAND, MARKER IS PLACED 8" TO 12" OFF CENTER ISLAND, OUT FROM HYDRANT.

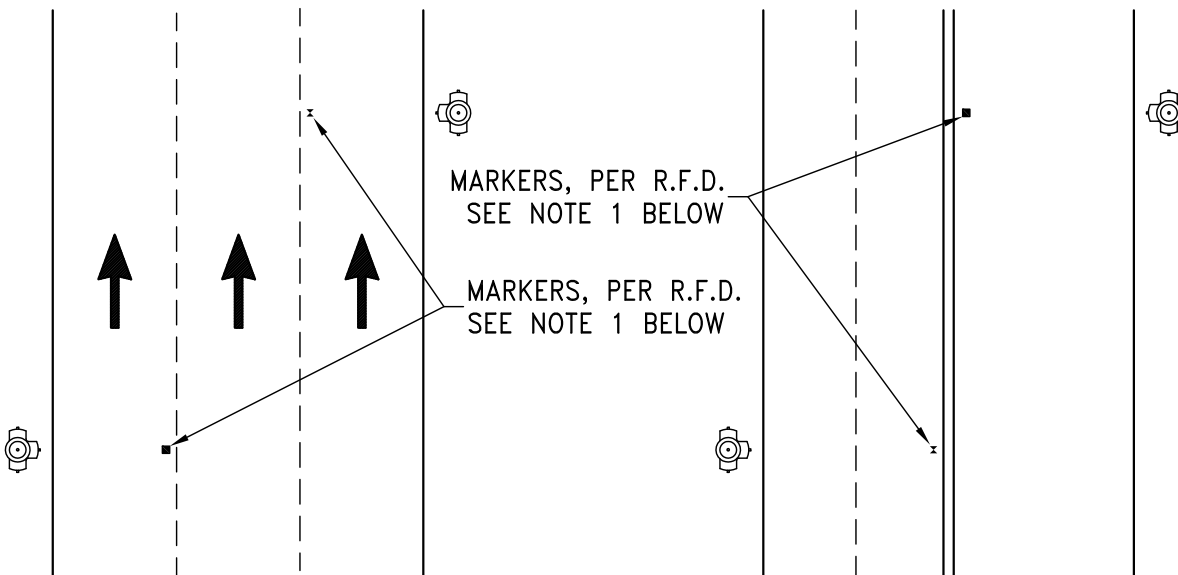

ONE WAY STREETS: MARKER IS PLACED 8" TO 12" OFF LINE IN FIRST LANE, OUT FROM HYDRANT.

2 LANE OR 4 LANE STREETS WITH CENTERLINE, MARKER IS PLACED 8" TO 12" OFF CENTERLINE. RESIDENTIAL STREETS WITH NO LINES, PLACE MARKER 8" TO 12" OFF VISUAL CENTER, TO THE SIDE OF THE HYDRANT.

NOTES:

1. R.F.D. - RENO FIRE DEPARTMENT

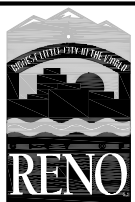

STANDARD DETAILS FOR PUBLIC WORKS CONSTRUCTION

DRAWING No.

**FIRE HYDRANT
MARKER LOCATIONS**

R-302

APPROVED BY: JF | DATE: 1/2013

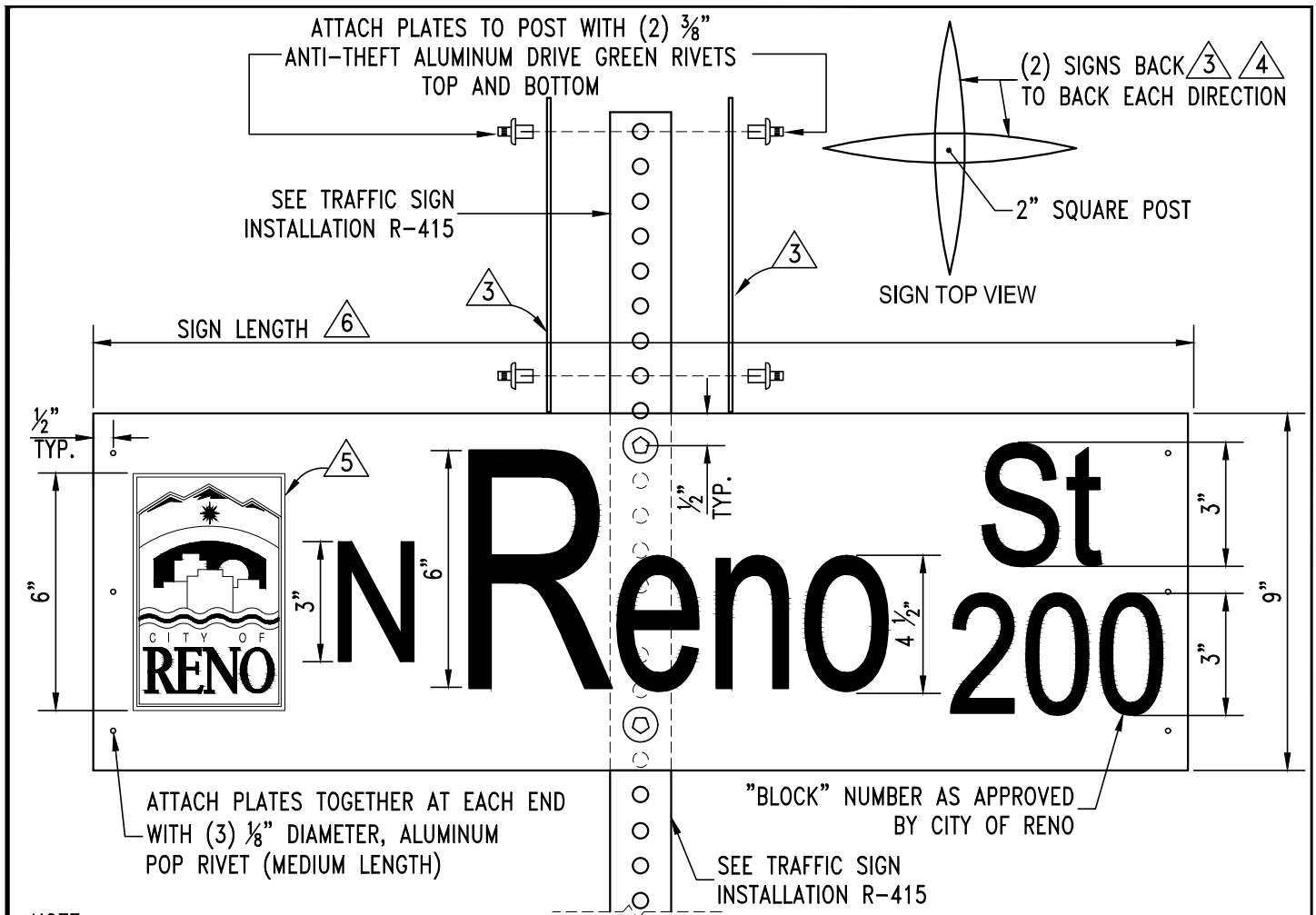

NOTE:

1. STREET NAME SIGN SHALL BE IN CONFORMANCE WITH THE LATEST EDITION OF THE MANUAL ON UNIFORM TRAFFIC CONTROL DEVICES.
2. ALL SIGN LETTERING SHALL BE IN UPPERCASE AND LOWERCASE LETTERS AND LETTERING FONT SERIES B 2000 AS PROVIDED IN THE STANDARD ALPHABETS FOR HIGHWAY SIGNS AND PAVEMENT MARKINGS.
3. EACH STREET NAME SIGN INSTALLATION SHALL HAVE (4) FLAT PLATE ALUMINUM NO. 6061-T6, .080 GAUGE.
4. EACH STREET NAME SIGN INSTALLATION SHALL INCLUDE (2) SIGNS BACK TO BACK EACH DIRECTION FOR A TOTAL OF (4) STREET NAME SIGNS. SEE DETAIL R-415 FOR TRAFFIC SIGN INSTALLATION.
5. CONTACT THE CITY OF RENO'S CORPORATION YARD AT 334-2246 FOR INFORMATION ON THE CITY OF RENO LOGO. LOGO EXTENTS SHALL NOT EXCEED 6 INCHES.
6. SIGN LENGTH VARIES 30" MINIMUM TO 42" MAXIMUM. LONGER STREET NAMES AND/OR THE USE OF DROP LETTERS (EXAMPLE LOWERCASE "g" AND "y") REQUIRE APPROVAL FROM CITY TRAFFIC ENGINEER.
7. ALL SIGNS SHALL BE 3M DIAMOND GRADE (DG3), SERIES 4000, SHEETING WITH A CLEAR, TRANSPARENT OVERLAY 3M #1160i (LATEST EDITION) OR APPROVED EQUAL. SHALL BE A MATCHED COMPONENT SYSTEM.
8. OVERLAY ACRYLIC EC FILMS, INKS AND DIGITAL IMAGING USED FOR ASSEMBLY SHALL BE APPROVED FOR USE BY THE MANUFACTURER OF THE SHEETING MATERIAL. THE SERVICE LIFE OF INKS AND FILMS SHALL BE COMPARABLE TO THE SHEETING USED. ALL LETTERS, NUMERALS, SYMBOLS, BORDERS, AND ACCESSORIES AS NECESSARY FOR THE SIGN LEGEND SHALL BE DIRECTLY APPLIED, DIGITALLY PRINTED, OR MOLDED TO FORM AN INTEGRAL SIGN LEGEND AND BACKGROUND ON ALL SIGNS.



STANDARD DETAILS FOR PUBLIC WORKS CONSTRUCTION

DRAWING No.

STREET NAME SIGN

R-401

APPROVED BY: KK | DATE: 2/2026

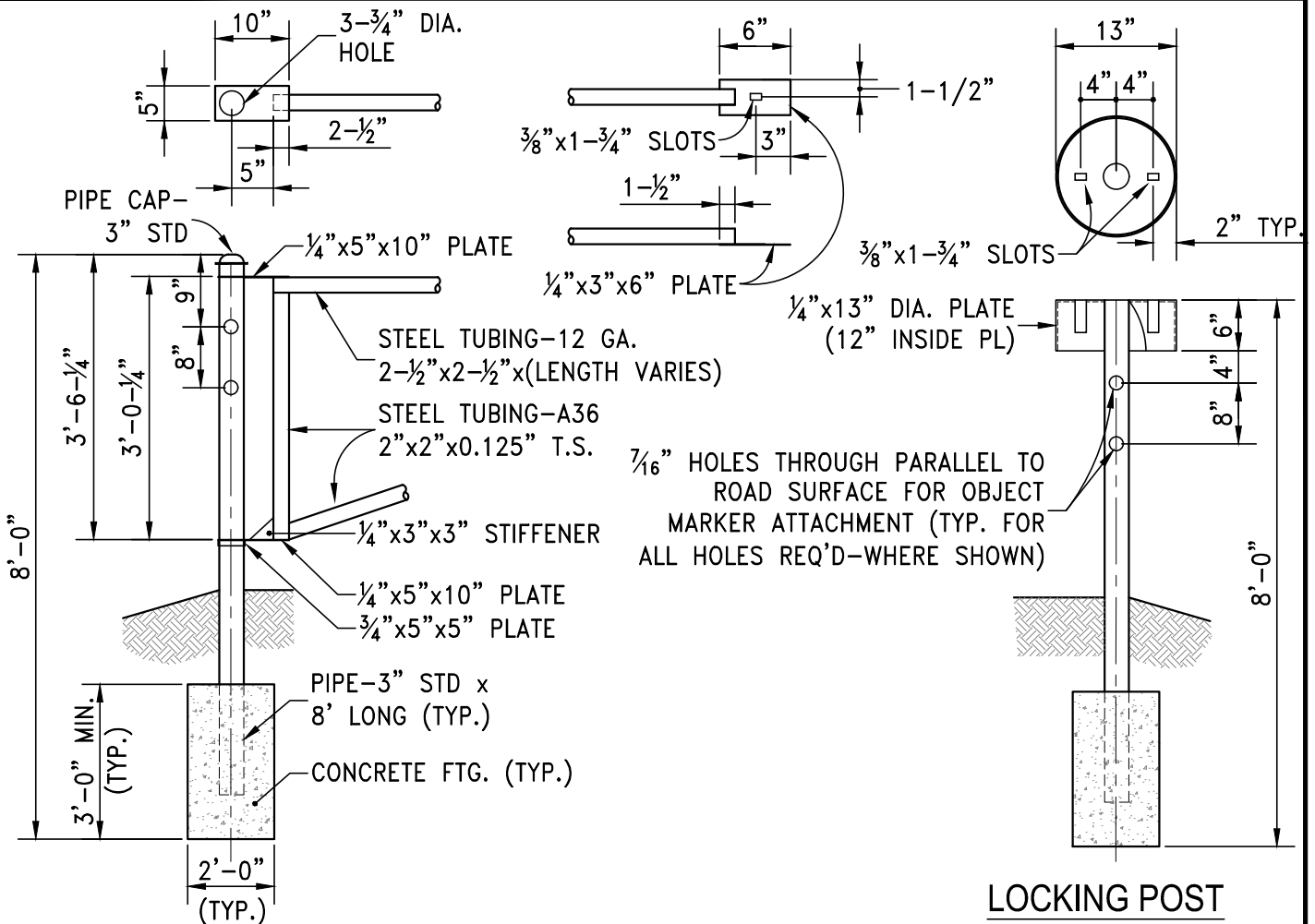

HINGE POST DETAIL

LOCKING POST

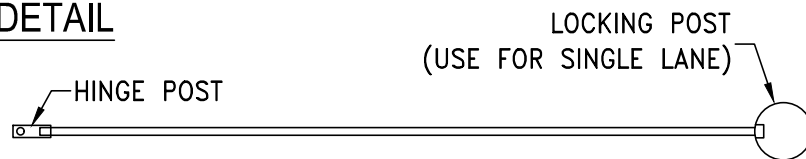

PLAN VIEW

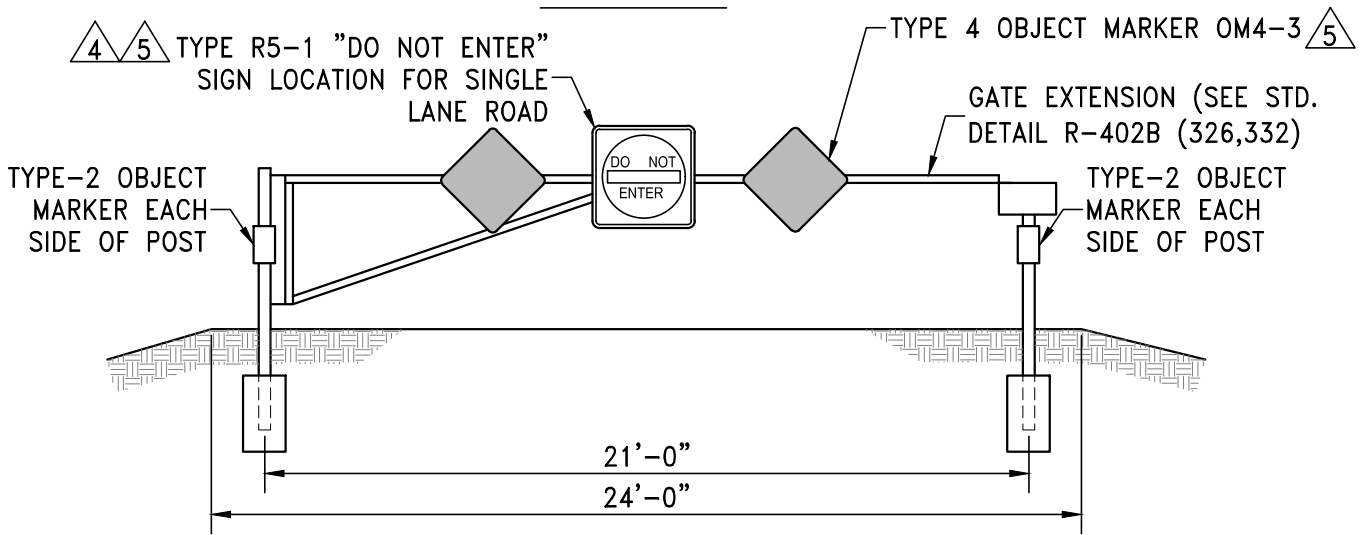

ELEVATION VIEW



STANDARD DETAILS FOR PUBLIC WORKS CONSTRUCTION

DRAWING No.

**EMERGENCY ACCESS
CONTROL GATE**

R-402A

APPROVED BY: KK DATE: 2/2026

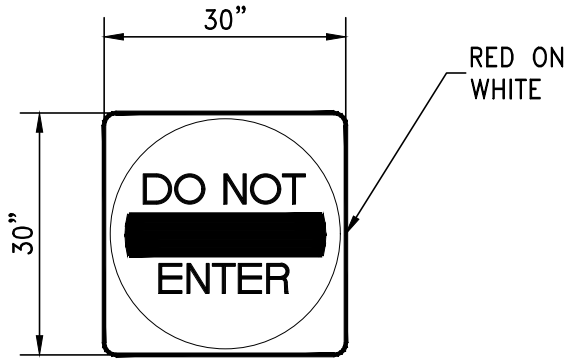

DO NOT ENTER SIGN
TYPE R5-1

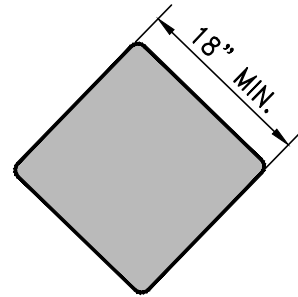

END OF ROADWAY MARKER

OM4-3
RETROREFLECTIVE RED DIAMOND PANEL.

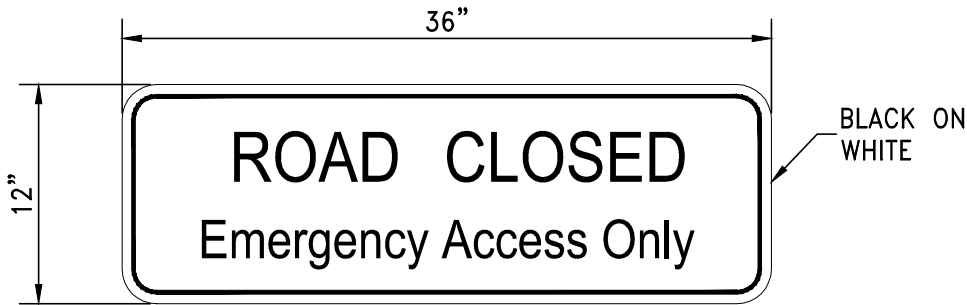

EMERGENCY ACCESS ROAD CLOSED SIGN **

** UTILIZE THIS SIGN IN LIEU OF THE "DO NOT ENTER" SIGN WHEN ACCESS BY THE FIRE DEPARTMENT IS REQUIRED.

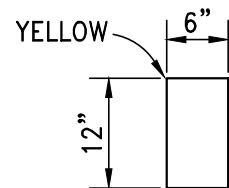

OBJECT MARKER

TYPE-2

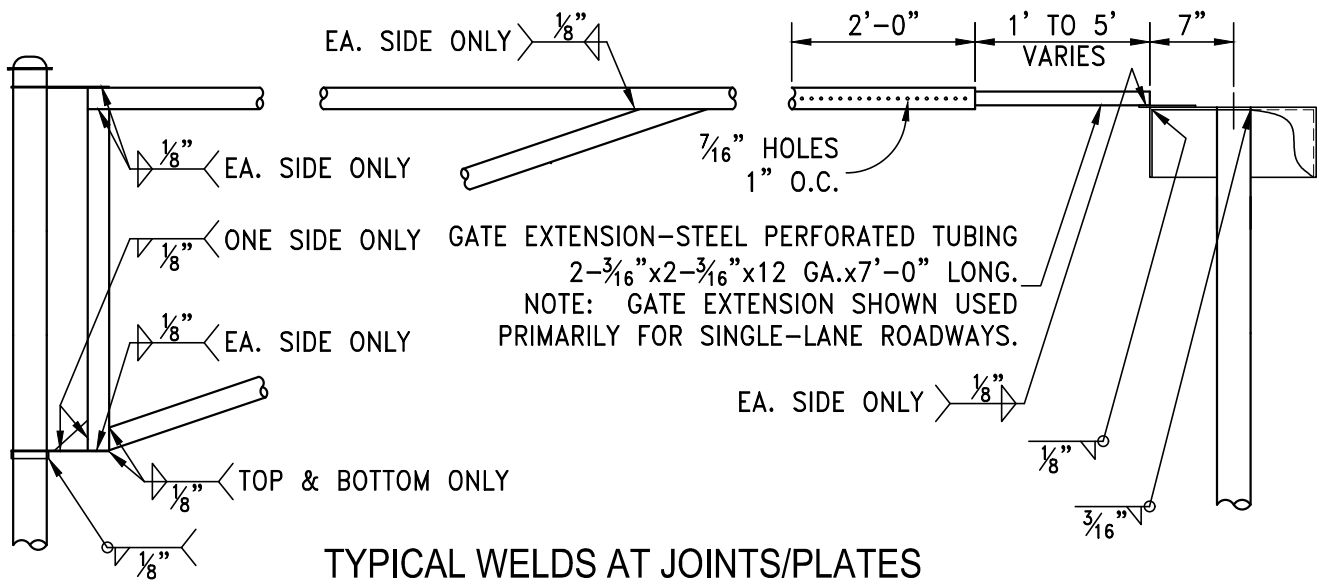

**TYPICAL WELDS AT JOINTS/PLATES
AND TYPICAL GATE EXTENSION**



STANDARD DETAILS FOR PUBLIC WORKS CONSTRUCTION

**EMERGENCY ACCESS
CONTROL GATE**

DRAWING No.

R-402B

APPROVED BY: KK | DATE: 2/2026

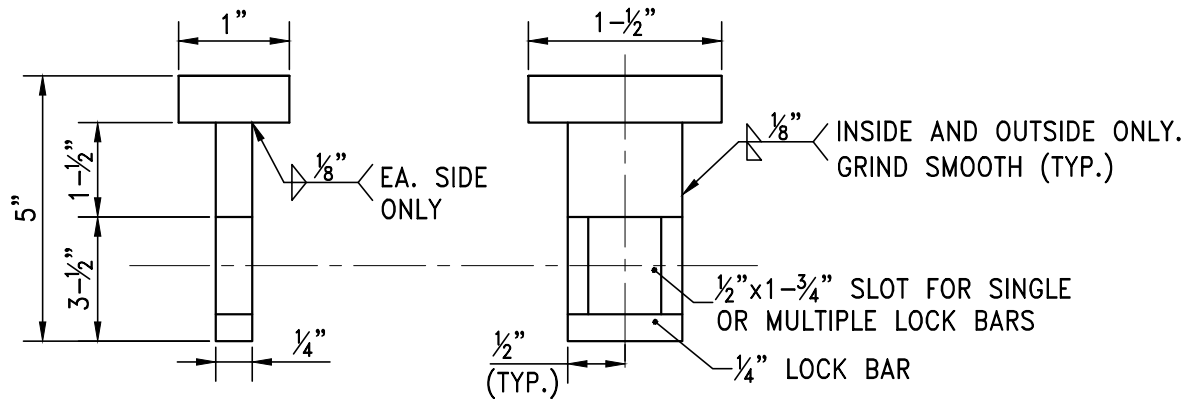

NOTES: (APPLY TO STD. DETAIL DWG. NOS. R-402A, R-402B AND R-402C)

1. ALL HOLES DRILLED THROUGH TO BE 7/16" DIAMETER. HOLES TYPICALLY DRILLED VERTICAL OR HORIZONTAL TO TRAVELED WAY SURFACE.
2. ALL THREADS OF ALL BOLTS USED ARE TO BE PEENED AFTER INSTALLATION/USAGE TO PREVENT BOLT REMOVAL.
3. ALL MEMBERS OF THE GATE ASSEMBLY SHALL BE FABRICATED FROM THE STANDARD STEEL SECTIONS. FABRICATED MEMBERS SHALL RECEIVE ONE SHOP COAT OF ALUMINUM PAINT AFTER FABRICATION. ALUMINUM PAINT SHALL CONFORM TO A.A.S.H.T.O. SPECIFICATION M69-70. HARDWARE SHALL BE CADMIUM PLATED.
4. SUBSTITUTE ITEM NO. 11 SIGN FOR ITEM NO. 6 SIGN WHEN ACCESS BY THE FIRE DEPARTMENT IS REQUIRED.
5. ALL SIGNS SHALL BE 3M DIAMOND GRADE (DG3), SERIES 4000, SHEETING WITH A CLEAR, TRANSPARENT OVERLAY 3M #1160i (LATEST EDITION) OR APPROVED EQUAL. SHALL BE A MATCHED COMPONENT SYSTEM.
6. OVERLAY ACRYLIC EC FILMS, INKS AND DIGITAL IMAGING USED FOR ASSEMBLY SHALL BE APPROVED FOR USE BY THE MANUFACTURER OF THE SHEETING MATERIAL. THE SERVICE LIFE OF INKS AND FILMS SHALL BE COMPARABLE TO THE SHEETING USED. ALL LETTERS, NUMERALS, SYMBOLS, BORDERS, AND ACCESSORIES AS NECESSARY FOR THE SIGN LEGEND SHALL BE DIRECTLY APPLIED, DIGITALLY PRINTED, OR MOLDED TO FORM AN INTEGRAL SIGN LEGEND AND BACKGROUND ON ALL SIGNS.

MATERIALS LIST

ITEM NO.	NO. REQ'D	DESCRIPTION
1	1	GATES AND GATE EXTENSIONS
2	1	HINGE POST, WITH PIPE CAPS
3	1	MASTER LOCKING PINS
4	1	LOCKING POST
5	2	OM4-3 END OF ROADWAY MARKER
6	1	DO NOT ENTER SIGN
7	4	6"X12" TYPE-2 OBJECT MARKERS
8	2	3/8"X3" MACHINE BOLT FOR GATE EXTENSIONS
9	6	3/8"X4" CARRIAGE BOLT WITH 1 CUT AND 1 LOCK WASHER FOR SIGNS ON GATES
10	6	3/8"X6" CARRIAGE BOLT WITH 1 CUT AND 1 LOCK WASHER FOR OBJECT MARKERS
11	1	ROAD CLOSED EMERGENCY ACCESS ONLY SIGN



STANDARD DETAILS FOR PUBLIC WORKS CONSTRUCTION

EMERGENCY ACCESS CONTROL GATE

DRAWING No.

R-402C

APPROVED BY: KK | DATE: 2/2026

SECTION B-B (SEE STANDARD
DETAIL R-403B)

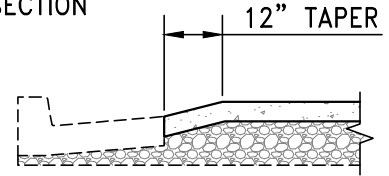
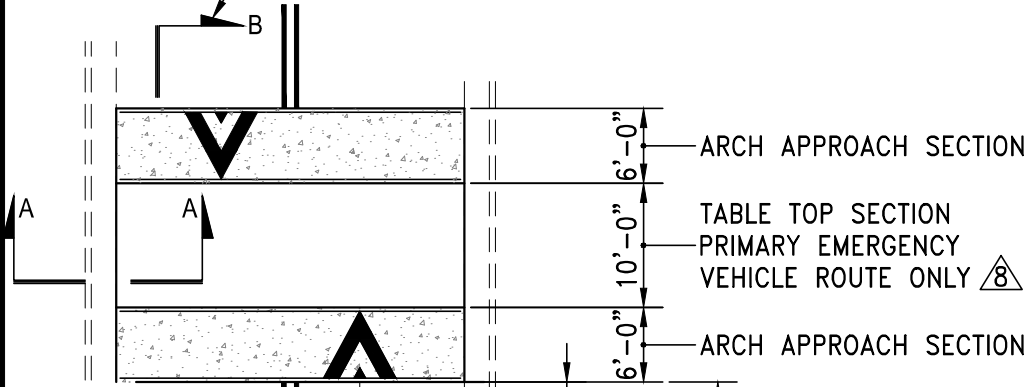

NOTE:
TAPER TO CONTINUE THROUGH APPROACH
ARC AND TABLE TOP SECTIONS

SECTION A-A

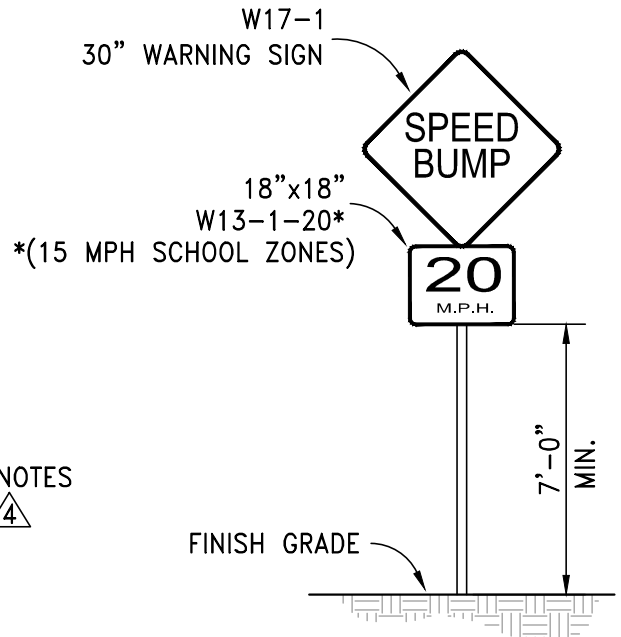
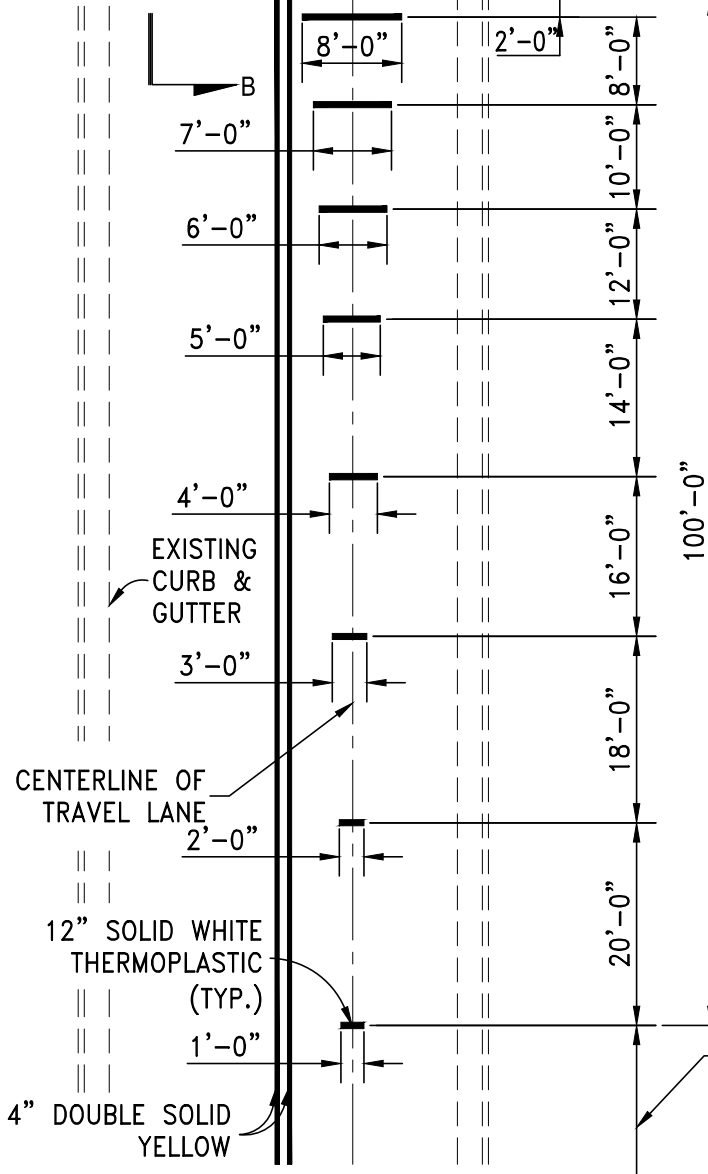

**PLAN -
STRIPING AND SIGNAGE**
(TYP. FOR BOTH DIRECTIONS)

SEE SIGN
DETAIL 1

SIGN DETAIL 1



STANDARD DETAILS FOR PUBLIC WORKS CONSTRUCTION

**SPEED BUMP LAYOUT,
SIGNAGE & STRIPING**

DRAWING No.

R-403A

APPROVED BY: KK | DATE: 2/2026

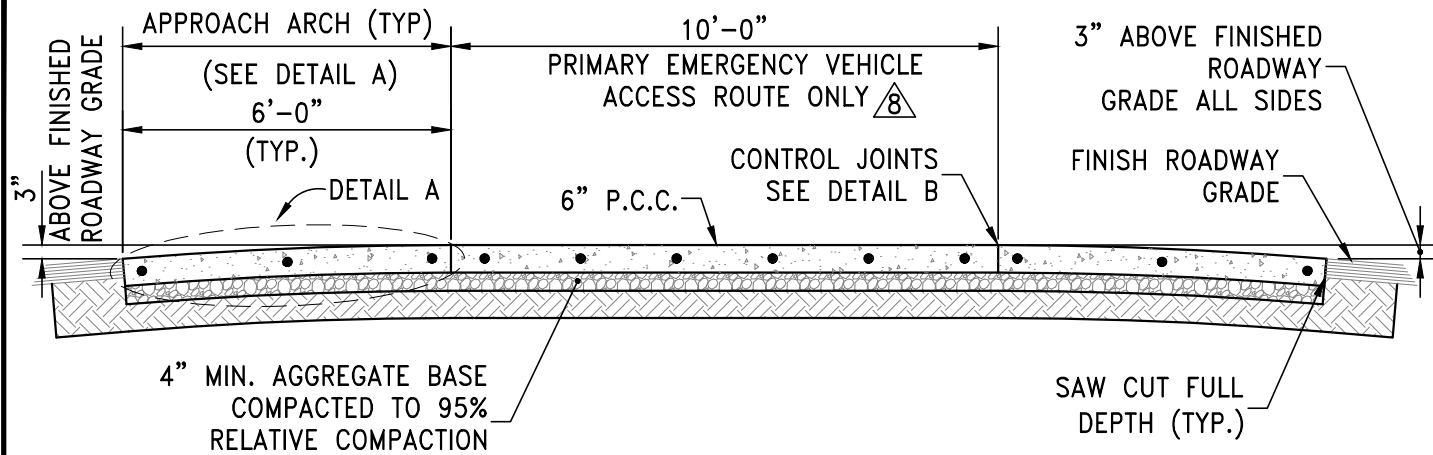

SECTION B-B
SPEED TABLE LONGITUDINAL PROFILE

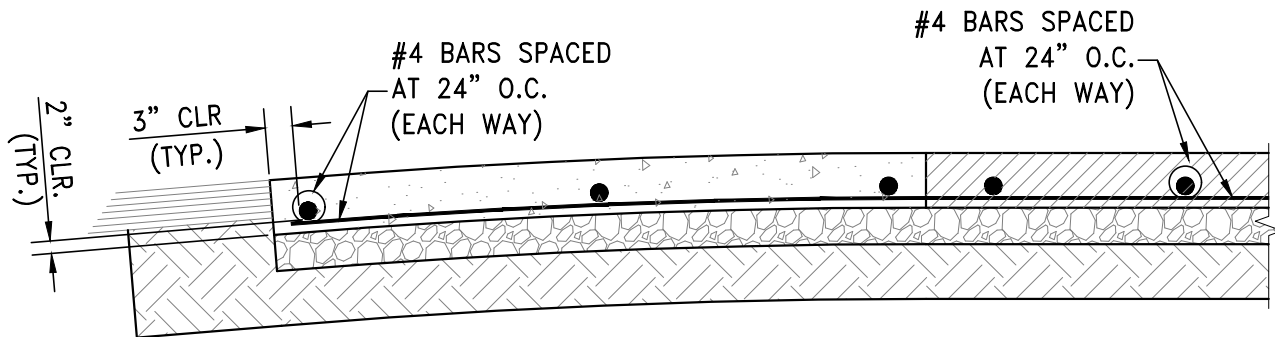

DETAIL A

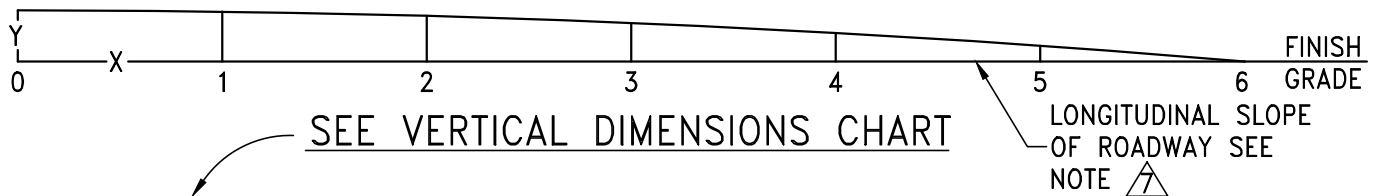

VERTICAL DIMENSIONS CHART *	
X(FT.)	Y(FT.)=INCHES
0	0.250=3.00
1	0.243=2.92
2	0.222=2.67
3	0.188=2.25
4	0.139=1.67
5	0.077=0.92
6	0.000=0.00

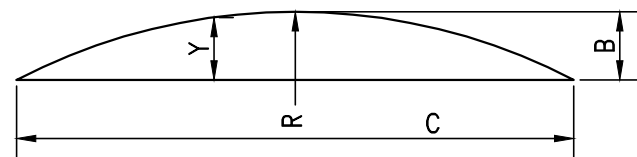

$$* R = \frac{4B^2 + C^2}{8B} = 72.125'$$

$$B = \text{HEIGHT} = (0.25')$$

$$C = \text{CHORD DISTANCE} = (12')$$



STANDARD DETAILS FOR PUBLIC WORKS CONSTRUCTION

SPEED BUMP
CROSS SECTIONS

DRAWING No.

R-403B

APPROVED BY: KK

DATE: 1/2023

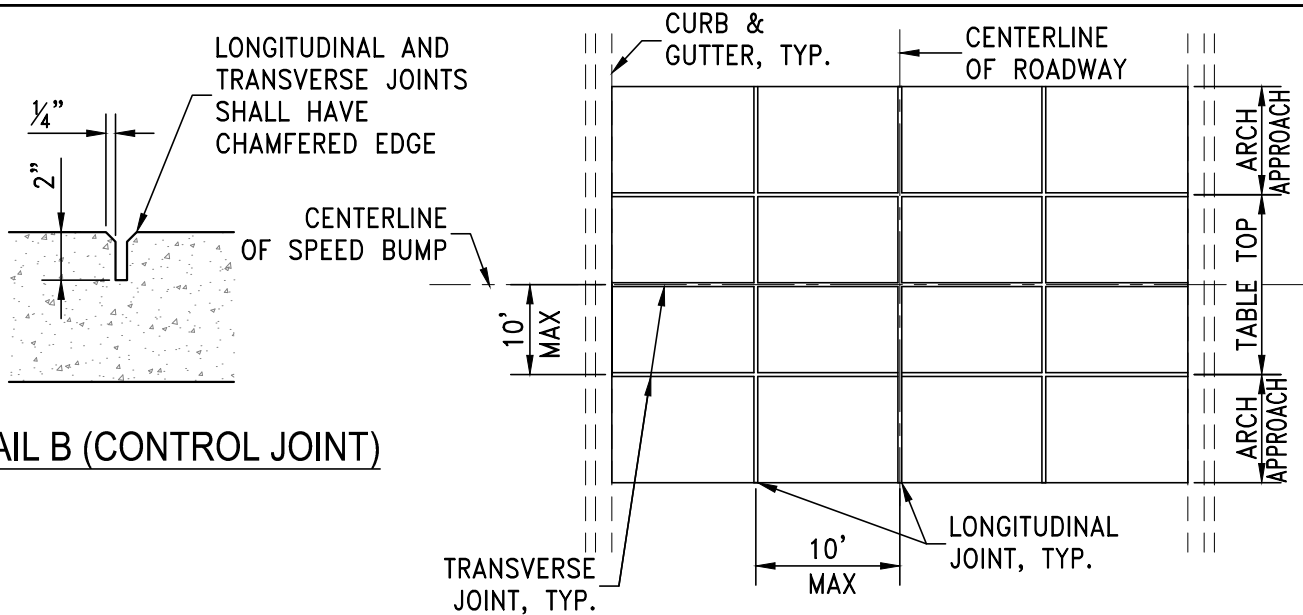

DETAIL B (CONTROL JOINT)

CONTROL JOINT PATTERN

NOTES:

1. PORTLAND CEMENT CONCRETE (P.C.C.) SHALL BE 4000 PSI MIN. COMPRESSIVE STRENGTH AT 28 DAYS. ALL CEMENT CONCRETE SHALL HAVE A COARSE AGGREGATE GRADATION CONFORMING TO SIZE No. 67. POLYPROPYLENE OR CELLULOSE FIBERS SHALL BE ADDED TO THE P.C.C. AT 1.5 LBS PER CUBIC YARD. MIX DESIGN SHALL CONFORM TO THE REQUIREMENTS OF SECTION 337.10 OF SSPWC. ALL MATERIALS SHALL CONFORM TO SSPWC.
2. AGGREGATE BASE MATERIAL UNDER SIDEWALKS SHALL BE TYPE 2, CLASS B CRUSHED AGGREGATE BASE. MATERIALS SHALL CONFORM TO SSPWC SECTION 200.
3. SIGN TO BE INSTALLED PER CITY OF RENO STANDARD DETAIL R-415.
4. EXACT LOCATION OF SPEED TABLE AND SIGNS TO BE VERIFIED BY THE ENGINEER PRIOR TO PLACEMENT.
5. LONGITUDINAL AND TRANSVERSE JOINTS TO BE CUT AT 10' MAX O.C. BEGINNING AT THE CENTERLINE. JOINTS SHALL BE CUT A MINIMUM OF 4 HOURS TO A MAXIMUM OF 12 HOURS AFTER THE CONCLUSION OF BRUSH FINISHING. SEE DETAIL B ABOVE.
6. FOR ROAD RECONSTRUCTION PROJECTS. SPEED TABLE SHALL BE PLACED AFTER THE ROADWAY HAS BEEN PAVED.
7. DIMENSIONS IN VERTICAL DIMENSIONS CHART ASSUME A LONGITUDINAL ROADWAY SLOPE OF 0.00%. IT IS THE INTENT OF THE DETAIL THAT THE 10' SECTION OF THE SPEED TABLE BE 3" ABOVE THE EXISTING ROADWAY ON ALL SIDES WITH THE EXCEPTION OF THE TAPER SECTION AT LIP LINE. MAXIMUM TOLERANCE ON SPEED TABLE TO BE $\pm 1/4$ INCH. SPEED TABLE OUT OF TOLERANCE MUST BE REMOVED AND REPLACED AS REQUIRED BY THE ENGINEER.
8. THE 10' TAPER SECTION IS TO BE USED ON PRIMARY EMERGENCY VEHICLE ACCESS ROUTES AND AT THE APPROVAL OF CITY OF RENO TRAFFIC ENGINEERING.



STANDARD DETAILS FOR PUBLIC WORKS CONSTRUCTION

**NOTES & SPEED BUMP
JOINT DETAILS**

DRAWING No.

R-403C

APPROVED BY: KK

DATE: 1/2023

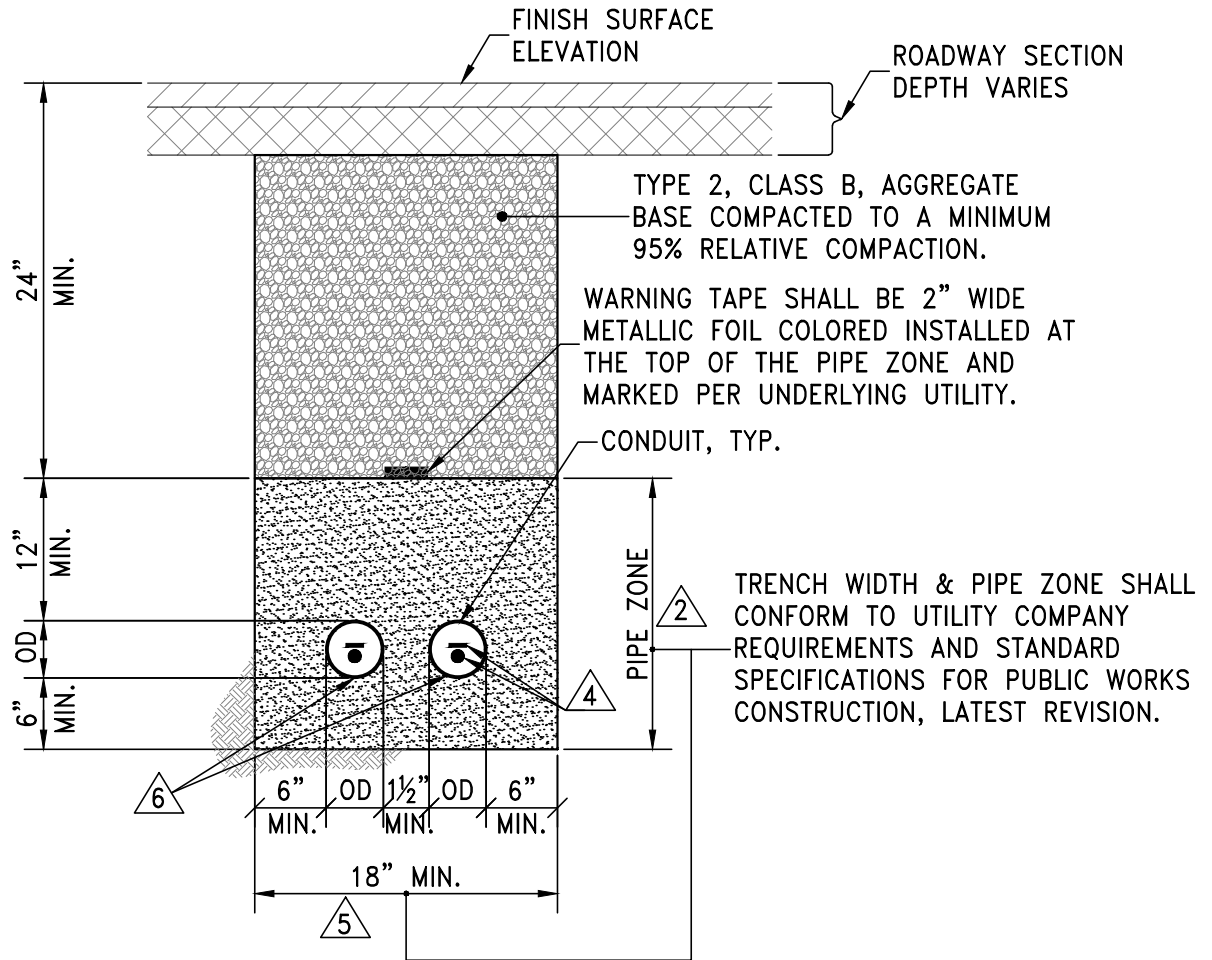

NOTES:

1. ALL MATERIALS AND INSTALLATION PROCEDURES SHALL BE IN ACCORDANCE WITH STANDARD SPECIFICATIONS FOR PUBLIC WORKS CONSTRUCTION (SSPWC), LATEST REVISION.

2. BEDDING MATERIAL SHALL CONFORM TO OWNING-UTILITY COMPANY REQUIREMENTS AS APPROVED BY THE CITY OF RENO. FOR CITY OWNED TRAFFIC AND LIGHTING UTILITIES, BEDDING MATERIAL SHALL BE CLASS A. COMPACTED TO MINIMUM 90% RELATIVE COMPACTION. MATERIALS SHALL CONFORM TO SSPWC SECTION 200.

3. CEMENT SLURRY BEDDING/BACKFILL SHALL NOT BE USED.

4. INSTALL LOCATE WIRE AND MULE TAPE FOR ALL FUTURE, UNUSED, OR FIBER-OPTIC CONDUITS. LOCATE WIRE SHALL BE 12 GAGE WIRE TERMINATED AT BOX & POLYESTER PULLING TAPE SHALL BE MULE TAPE OR APPROVED EQUAL.

5. ALL EXCAVATIONS SHALL CONFORM TO THE LATEST O.S.H.A. REQUIREMENTS.

6. POWER AND COMMUNICATIONS SHALL BE PLACED IN SEPARATE CONDUITS.



STANDARD DETAILS FOR PUBLIC WORKS CONSTRUCTION

**TRAFFIC & LIGHTING
CONDUIT TRENCH**

DRAWING No.

R-404

APPROVED BY: KK

DATE: 2/2026

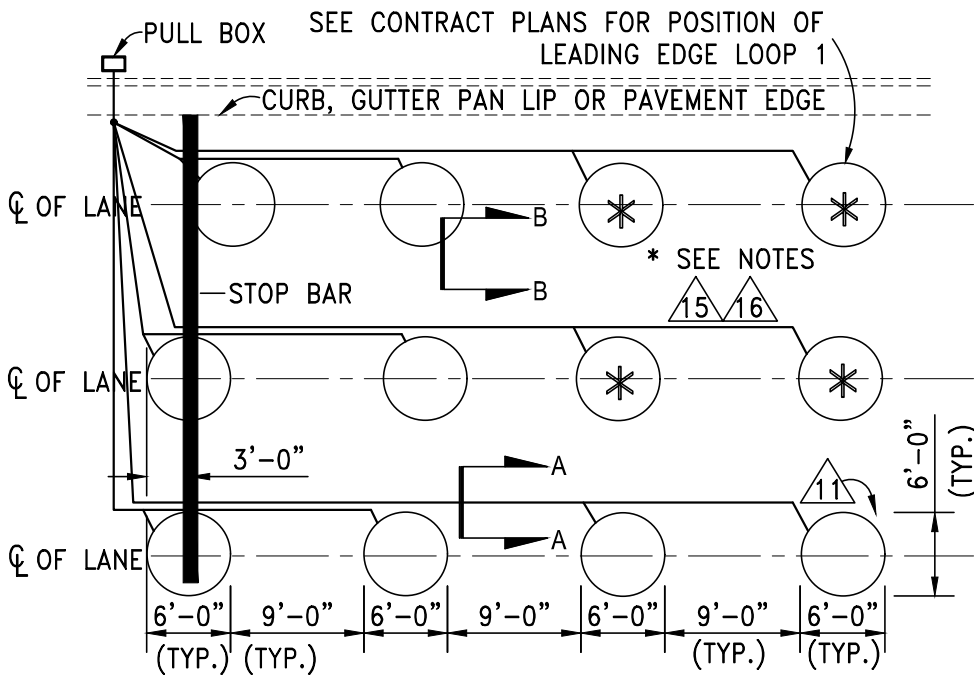

7 PLAN VIEW

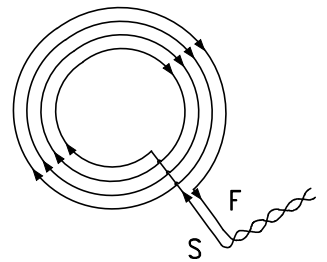

7 WINDING DETAIL

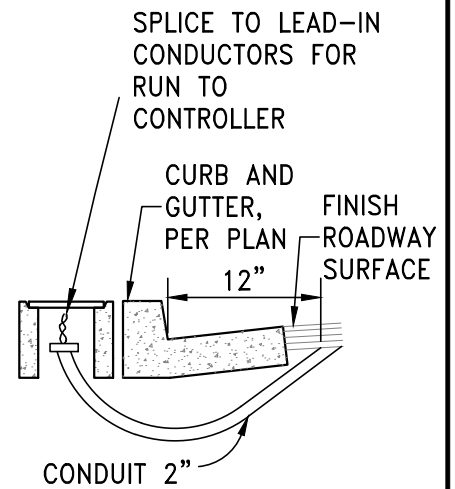

7 CONDUIT INSTALLATION

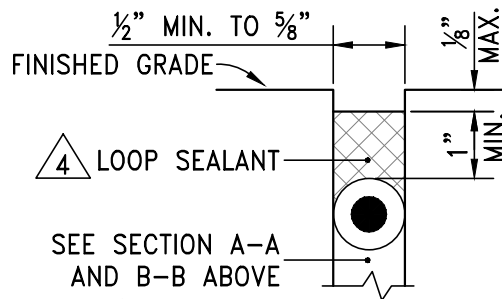

6 DETAIL A - FOR CUT IN LOOPS

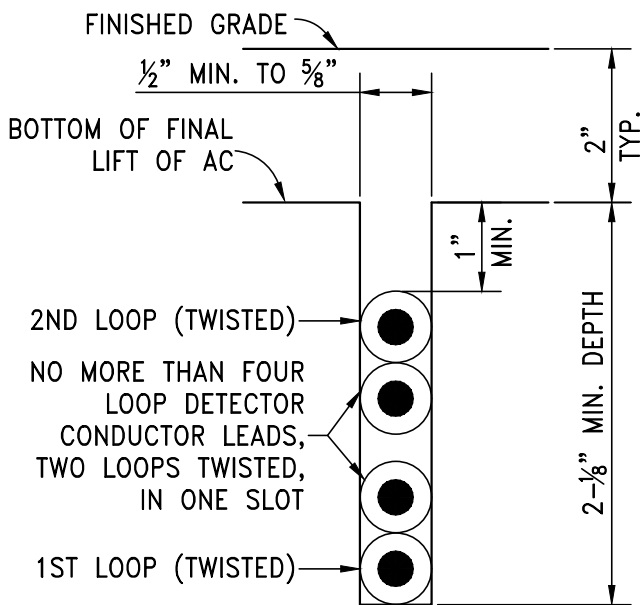

2 3 SECTION A-A

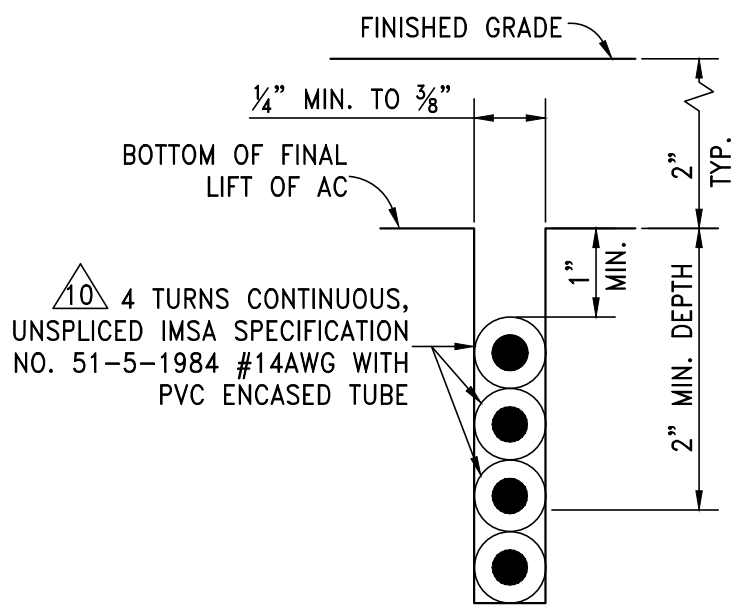

2 3 SECTION B-B



STANDARD DETAILS FOR PUBLIC WORKS CONSTRUCTION

DRAWING No.

LOOP DETECTOR LAYOUT

R-406A

APPROVED BY: KK

DATE: 2/2026

NOTES:

1. CIRCULAR LOOPS ARE REQUIRED FOR ALL DETECTOR LOOPS UNLESS NOTED IN THE CONTRACT.
2. WHERE NEW PAVEMENT SURFACES ARE PLACED, ALL TRAFFIC SIGNAL LOOP DETECTORS SHALL BE INSTALLED PRIOR TO THE PLACEMENT OF THE FINAL "TOP" LIFT OF THE PLANTMIX BITUMINOUS PAVEMENT MATERIAL. PLACEMENT OF SLURRY SEAL DOES NOT NEGATE THIS REQUIREMENT. SEE DETAIL R-406A, SECTIONS A-A AND B-B.
3. WHERE LOOPS ARE TO BE OVERLAID WITH ASPHALT, THE LOOP SEALANT SHALL BE SAKRETE, OR APPROVED EQUAL, AND COMPACTED.
4. LOOPS CUT INTO THE STREET SURFACE SHALL BE SEALED WITH "CRAFCO" LOOP SEALANT, OR AN APPROVED EQUAL.
5. WASH, BLOW OUT, AND DRY SLOTS THOROUGHLY WITH COMPRESSED AIR BEFORE INSTALLING LOOP CONDUCTORS.
6. SAW SLOTS IN PAVEMENT FOR LOOP CONDUCTORS AS SHOWN IN R-406A DETAIL A.
7. LOOPS SHALL BE CENTERED IN LANES AS SHOWN IN "PLAN VIEW" ON R-406A.
8. INSTALL TERMINATION PULL BOX PER "CONDUIT INSTALLATION" ON R-406A.
9. INSTALL NO. 14 AWG PVC ENCASED TUBE LOOP CONDUCTOR IN SLOTS USING $\frac{3}{16}$ " TO $\frac{1}{4}$ " THICK WOOD PADDLE. SEE R-406A SECTIONS B-B. ALLOW ADDITIONAL LENGTH FOR THE LEAD-IN RUN TO TERMINATION PULL BOX PLUS SO THAT THERE IS 5' OF SLACK IN PULL BOX. THIS ADDITIONAL LENGTH OF CONDUCTOR FOR EACH LOOP CIRCUIT SHALL BE TWISTED TOGETHER IN A PAIR, AT LEAST 5 TURNS PER FOOT, BEFORE BEING RUN TO PULL BOX.
10. ALL WIRES SHALL BE IDENTIFIED IN PULL BOXES, WITH LOOP WIRES AS FOLLOWS: BLUE TAPE INDICATES LEFT TURN LANE LOOPS WITH ONE BAND IDENTIFYING LOOP ONE, TWO BANDS LOOP TWO, ETC. WHITE TAPE INDICATES THROUGH LANE LOOPS AND RED TAPE INDICATES RIGHT TURN LANES. IF THERE ARE TWO LEFT TURN LANES, YELLOW TAPE INDICATES THE LANE CLOSEST TO THE CENTER LANE OF THE STREET. IN THE LOOP PAIRS ALSO IDENTIFY WHICH IS THE START(S) AND FINISH(F) OF THE CONDUCTOR AS SHOWN IN "WINDING DETAIL" ON SHEET R-406A.
11. LEFT TURN LOOP FARTHEST FROM FROM STOP BAR SHALL BE ON DEDICATED CHANNEL.
12. SPLICE LOOP CONDUCTORS TO LEAD-IN CABLE. ALL SPLICES SHALL BE SOLDERED USING $\frac{40}{60}$ RESIN CORE SOLDER. ALL SPLICES SHALL BE PROVIDED A SOUND ENVIRONMENTAL SEAL. LEAD-IN CABLE SHALL NOT BE SPLICED BETWEEN THE TERMINATION PULL BOX AND THE CONTROLLER CABINET.
13. DISTANCE BETWEEN SIDE OF LOOP AND A LEAD-IN SAW CUT FROM ADJACENT DETECTORS SHALL BE TWO FEET MINIMUM. DISTANCE BETWEEN LEAD-IN SAW CUTS SHALL BE SIX INCHES MINIMUM. DISTANCE BETWEEN LEAD-IN SAW CUTS SHALL BE TWELVE INCHES FROM ANY CURB, GUTTER PAN LIP OR PAVEMENT EDGE.
14. ALL INDUCTIVE LOOPS ON A GIVEN CHANNEL SHALL BE CONNECTED IN SERIES. NO MORE THAN ONE LEAD IN CABLE SHALL BE CONNECTED TO A CABINET CHANNEL TERMINATION. NO MORE THAN 4 LOOPS ARE TO BE CONNECTED TO ONE CHANNEL.



STANDARD DETAILS FOR PUBLIC WORKS CONSTRUCTION

DRAWING No.

NOTES - LOOP DETECTOR LAYOUT

R-406B

APPROVED BY: KK | DATE: 2/2026

NOTES CONT:

15. FOR SPEEDS LESS THAN 35MPH AND LEFT TURN POCKETS, FOUR LOOPS SHALL BE PLACED ACCORDING TO R-406A, "PLAN VIEW".
16. LISTED BELOW ARE THE MINIMUM DISTANCES FOR ADVANCE LOOP DETECTOR PLACEMENT AS A FUNCTION OF POSTED SPEED LIMITS, MEASURED FROM THE STOP BAR TO THE REAR OF THE LOOP. THIS APPLIES FOR THROUGH TRAVEL LANES ONLY. SEE TABLE BELOW.

16

SPEED LIMIT (MPH)	DISTANCE (FEET)
35	255
40	285
45	330
50	355
55	390



STANDARD DETAILS FOR PUBLIC WORKS CONSTRUCTION

DRAWING No.

NOTES - LOOP DETECTOR LAYOUT

R-406C

APPROVED BY: KK | DATE: 2/2026

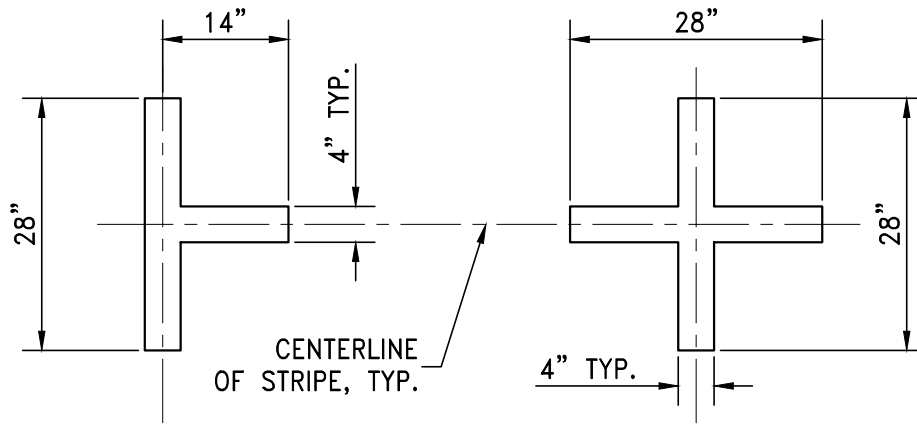

DETAIL A

DETAIL B

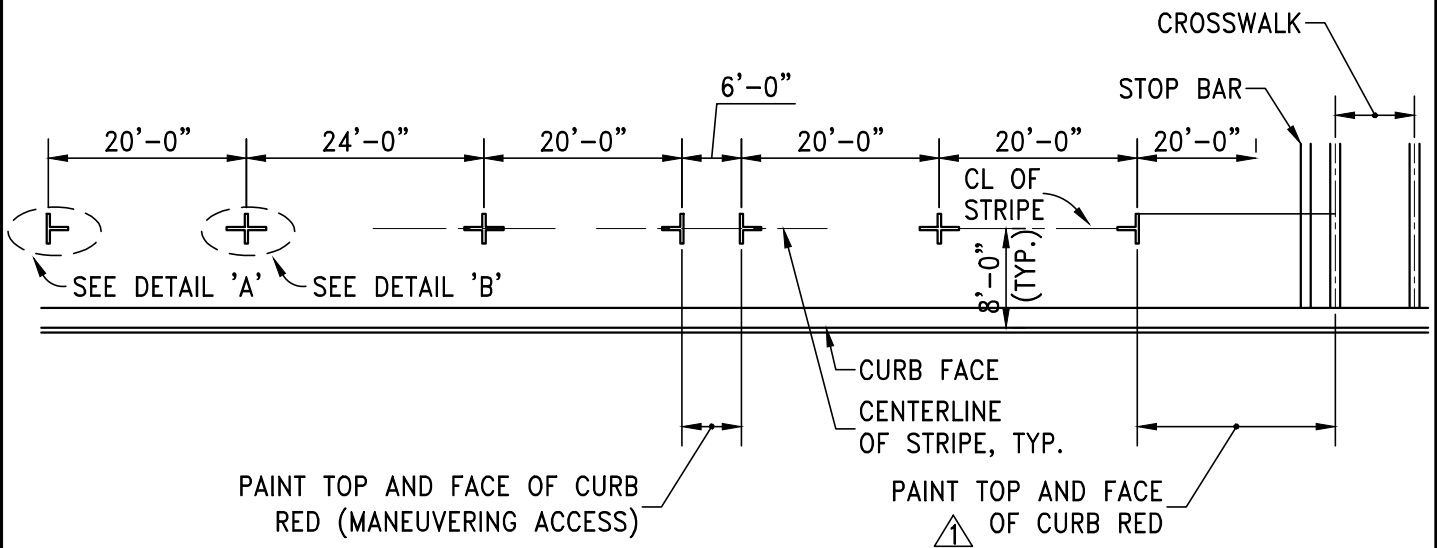

PLAN LAYOUT

NOTES:

1. NO PARKING WITHIN 20 FEET OF A CROSSWALK OR 15 FEET ON EITHER SIDE OF A FIRE HYDRANT.
2. PARKING SPACE MARKINGS SHALL BE WHITE, TRAFFIC PAINT. MATERIAL AND APPLICATION SHALL BE IN ACCORDANCE WITH STANDARD SPECIFICATIONS FOR PUBLIC WORKS CONSTRUCTION, LATEST EDITION.
3. PARKING SPACE MARKINGS SHALL BE SYMMETRICAL ABOUT AXIS.



STANDARD DETAILS FOR PUBLIC WORKS CONSTRUCTION

DRAWING No.

PARKING SPACE MARKINGS

R-407

APPROVED BY: KK | DATE: 2/2026

3/8" DIA BRASS OR STAINLESS STEEL STUD BOLTS, NUTS, & WASHERS—2 PER BOX. RECESS BOLT IN COVER.

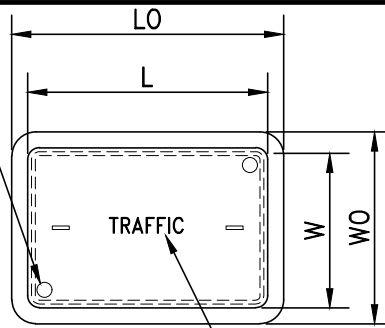

PLAN

RAISED INSCRIPTION LETTER HEIGHT TO BE 1" MIN. TO 3" MAX WITH WORDS "TRAFFIC" OR "LIGHTING"

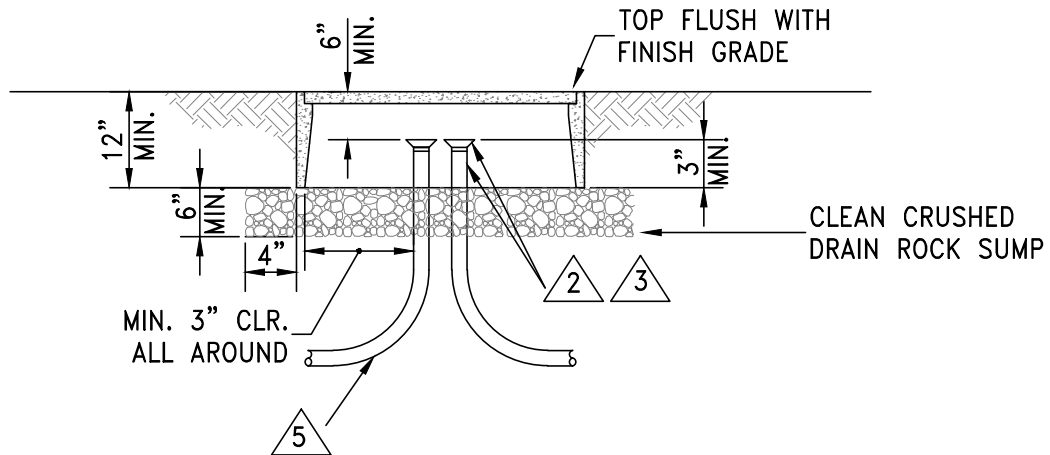

SECTION A-A

PULL BOX MINIMUM DIMENSION TABLE				
PULL BOX	CONCRETE BOX		COVER (PCC ONLY)	
	LO	WO	L	W
No. 3-1/2	20"	14"	15-3/8"	10-1/4"
No. 5	28"	18"	23-1/4"	13-3/4"

NOTES:

1. No. 5 PULL BOX SHALL BE USED AT LOCATION WHERE CONDUIT RUNS CONTAIN TRAFFIC SIGNAL CABLE OR CARRY POWER. No. 3-1/2 SHALL ONLY BE USED AS APPROVED BY CITY OF RENO TRAFFIC ENGINEER.
2. ALL CONDUIT TERMINATIONS SHALL HAVE A "BELL END" INSTALLATION AND BE SEALED WITH CONDUIT SEALER AFTER WIRE INSTALLATION.
3. ALL EXPOSED CONDUIT SHALL BE RIGID PVC SCHEDULE 80, AND SHALL EXTEND TO A MINIMUM DEPTH OF 18 INCHES.
4. BOX EXTENSIONS SHALL NOT BE USED UNLESS APPROVED BY CITY OF RENO TRAFFIC ENGINEER.
5. CONDUIT ENDS SHALL NOT TERMINATE WITHIN A SWEEP SECTION.
6. PULL BOXES THAT CONTAIN TRAFFIC CABLE, POWER, OR COMMUNICATIONS SHALL BE TRAFFIC RATED (R-412B).



STANDARD DETAILS FOR PUBLIC WORKS CONSTRUCTION

DRAWING No.

STANDARD PULL BOX

R-412A

APPROVED BY: KK | DATE: 2/2026

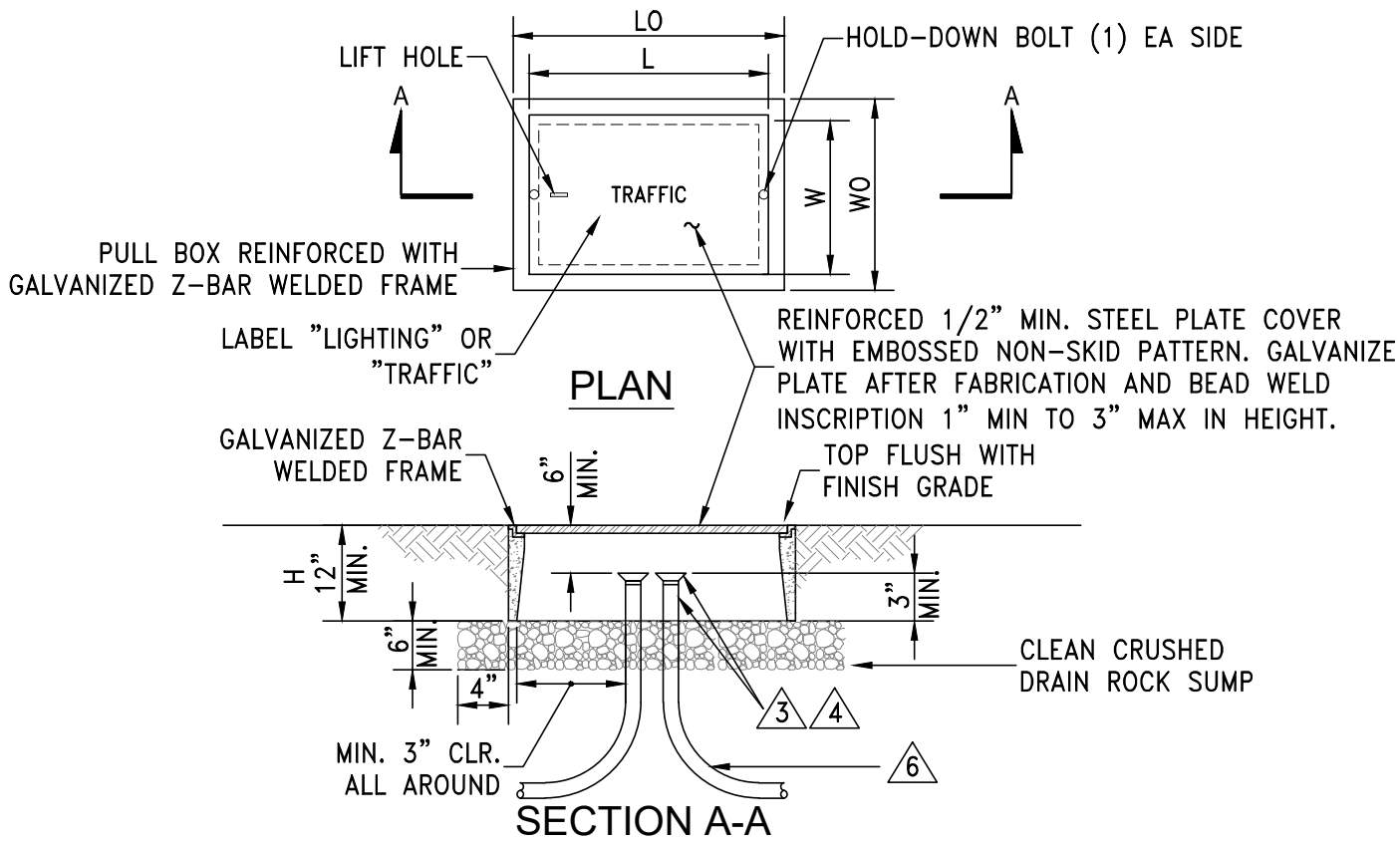

TRAFFIC RATED PULL BOX MINIMUM DIMENSION TABLE

PULL BOX	CONCRETE BOX		COVER (STEEL COVER)		HEIGHT
	LO	WO	L	W	
No. 3-1/2	19"	12"	14-1/2"	8-3/4"	12"
No. 5	25"	15"	20-1/2"	10-1/2"	12"
No. 7	35"	22"	30"	17"	12"
No. 9	52"	35"	47-3/4"	30"	14"

NOTES:

1. A MINIMUM OF No. 5 TRAFFIC RATED PULL BOXES SHALL BE USED AT LOCATION WHERE CONDUIT RUNS CONTAIN TRAFFIC SIGNAL CABLE. A MINIMUM OF No. 7 TRAFFIC RATED PULL BOXES SHALL BE USED WHERE FIBER IS PRESENT.
2. TRAFFIC RATED BOX SHALL BE USED IN VEHICULAR AREAS ONLY, INCLUDING, BUT NOT LIMITED TO TRAVEL WAY, DRIVEWAY APPROACHES AND WITHIN PEDESTRIAN RAMPS AT INTERSECTION CURB RETURNS OR AS APPROVED BY CITY OF RENO TRAFFIC ENGINEER. PULL BOXES THAT CONTAIN TRAFFIC CABLE, POWER, OR COMMUNICATIONS SHALL BE TRAFFIC RATED.
3. ALL CONDUIT TERMINATIONS SHALL HAVE A "BELL END" INSTALLATION AND BE SEALED WITH CONDUIT SEALER AFTER WIRE INSTALLATION.
4. ALL EXPOSED CONDUIT SHALL BE RIGID PVC SCHEDULE 80, AND SHALL EXTEND TO A MINIMUM DEPTH OF 18 INCHES.
5. BOX EXTENSIONS SHALL NOT BE USED UNLESS APPROVED BY CITY OF RENO TRAFFIC ENGINEER.
6. CONDUIT ENDS SHALL NOT TERMINATE WITHIN A SWEEP SECTION.
7. ALL METAL COVERS, METAL Z-BAR FRAME, METAL RINGS OR ANY METALLIC COMPONENT OF A PULL BOX SHALL BE BONDED TO A #8 AWG OR LARGER COPPER EQUIPMENT GROUNDING CONDUCTOR. BONDING JUMPERS SHALL BE BRAIDED COPPER EQUIVALENT TO #8 AWG COPPER AND MINIMUM 36" IN LENGTH AND SHALL BE ATTACHED WITH EXOTHERMIC WELDING. PROCESS IS A MOLECULAR BONDING WITH HIGH COPPER CONTENT ALLOYS (IN EXCESS OF 90%), HIGH CORROSION RESISTANCE AND HIGH CONDUCTIVITY, AND APPROVED GROUNDING LUG.
8. PULL BOX SHALL NOT BE INSTALLED WITHIN THE BOUNDARIES OF NEW OR EXISTING CURB RAMPS OR IN ROADWAY SECTION.



STANDARD DETAILS FOR PUBLIC WORKS CONSTRUCTION

DRAWING No.

TRAFFIC RATED PULL BOX

R-412B

APPROVED BY: KK

DATE: 2/2026

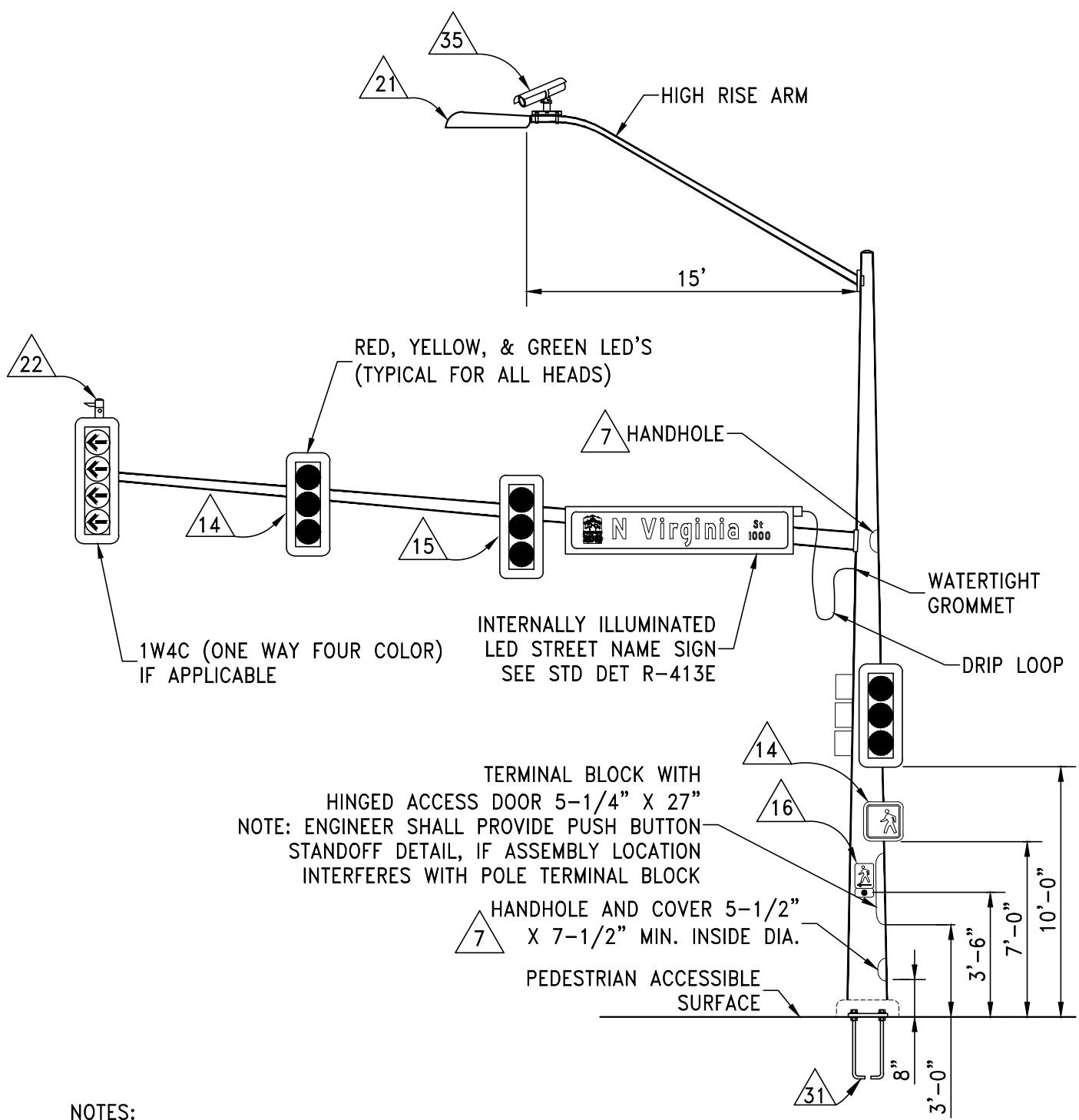

NOTES:

FOR ADDITIONAL DETAIL REFER TO CITY OF RENO GENERAL TRAFFIC SIGNAL NOTES.



STANDARD DETAILS FOR PUBLIC WORKS CONSTRUCTION

**TRAFFIC SIGNAL POLE
AND EQUIPMENT**

DRAWING No.

R-413A

APPROVED BY: KK

DATE: 2/2026

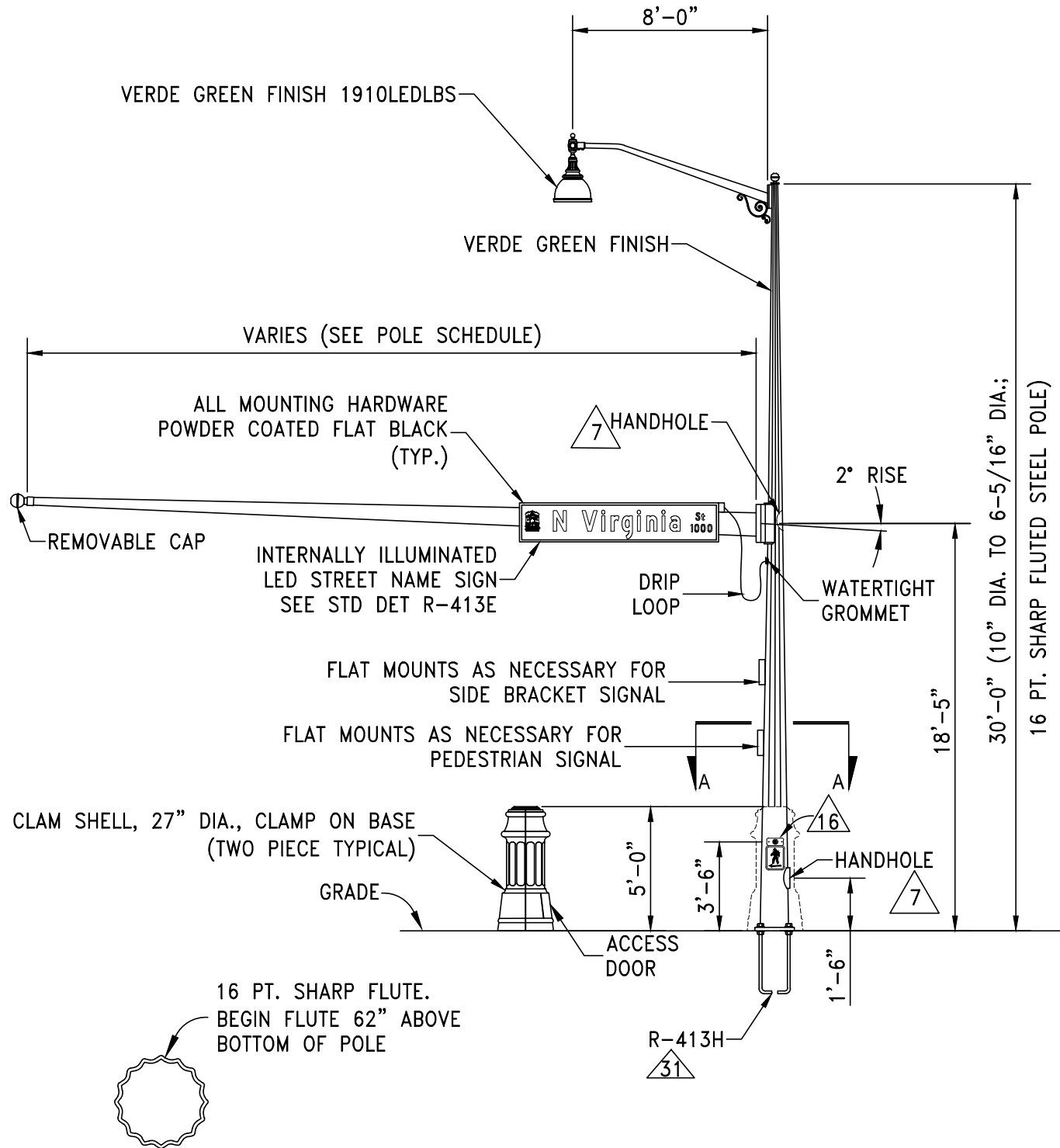

SECTION A-A



STANDARD DETAILS FOR PUBLIC WORKS CONSTRUCTION

DRAWING No.

TRAFFIC SIGNAL
DECORATIVE POLE

R-413B

APPROVED BY: KK | DATE: 2/2026

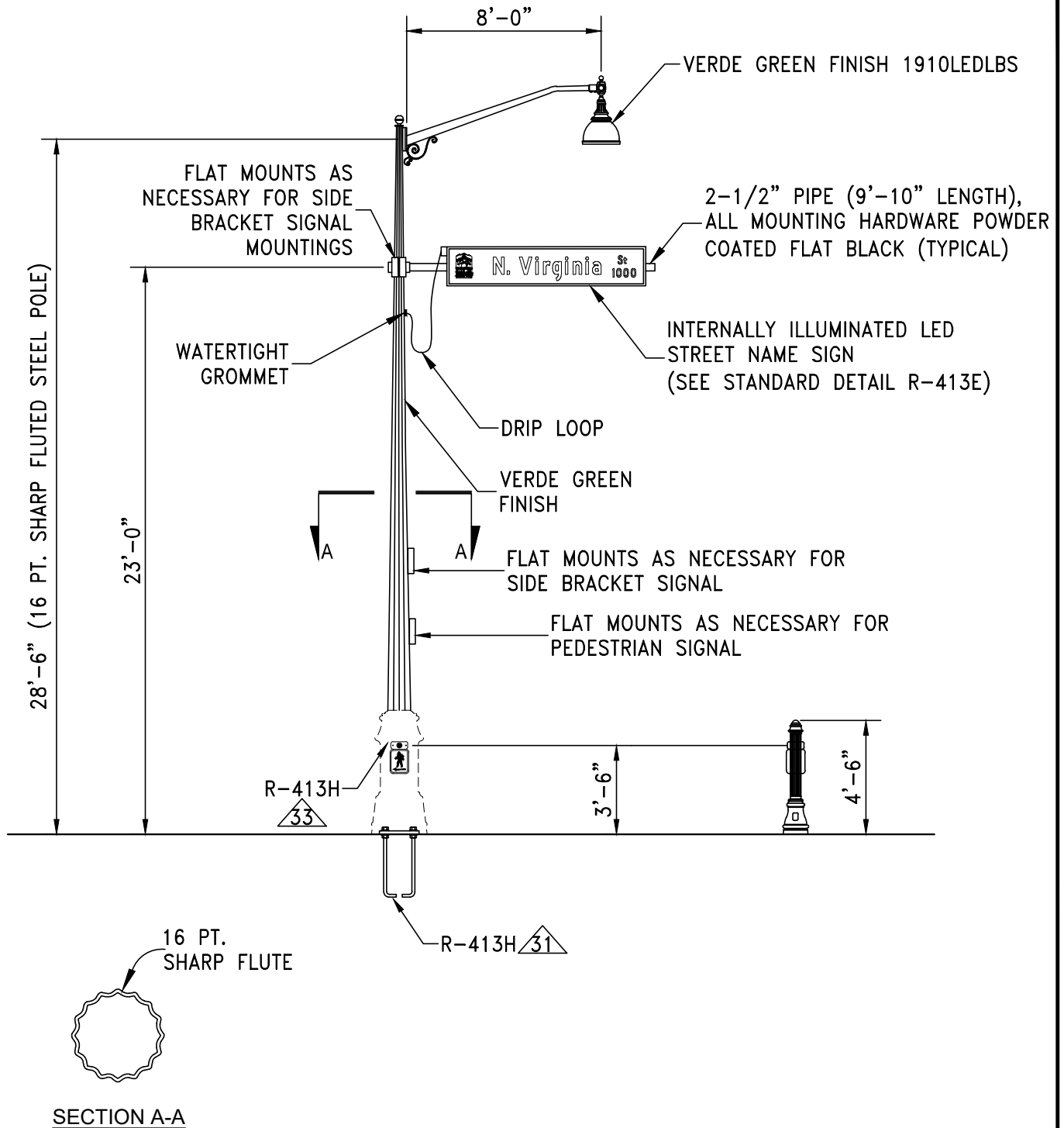

STANDARD DETAILS FOR PUBLIC WORKS CONSTRUCTION

DRAWING No.

DECORATIVE STREET LIGHT POLE

R-413C

APPROVED BY: KK DATE: 2/2026

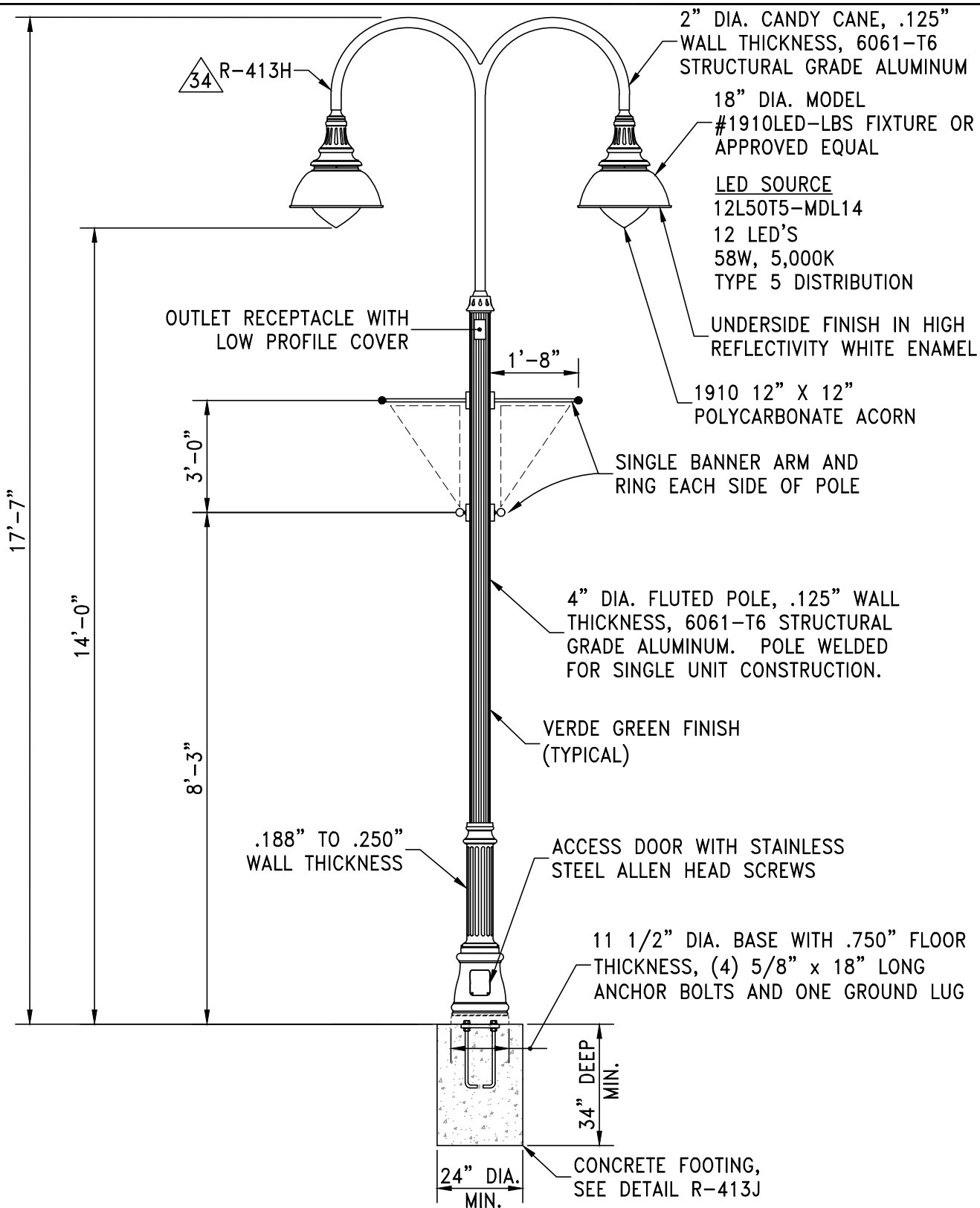

NOTES:

CITY OF RENO DECORATIVE STREET LIGHT POLE IS MANUFACTURED BY "STERNBERG LIGHTING." THE MATERIAL STYLE AND COLOR OF THE POLE AND LIGHTING FIXTURES SHALL MATCH PREVIOUS PHASES OF DOWNTOWN IMPROVEMENTS TO THE SATISFACTION OF THE CITY OF RENO. NO EQUAL ALTERNATIVES WILL BE ALLOWED.



STANDARD DETAILS FOR PUBLIC WORKS CONSTRUCTION

DRAWING No.

**DECORATIVE STREET
LIGHT POLE**

R-413D

APPROVED BY: KK | DATE: 2/2026

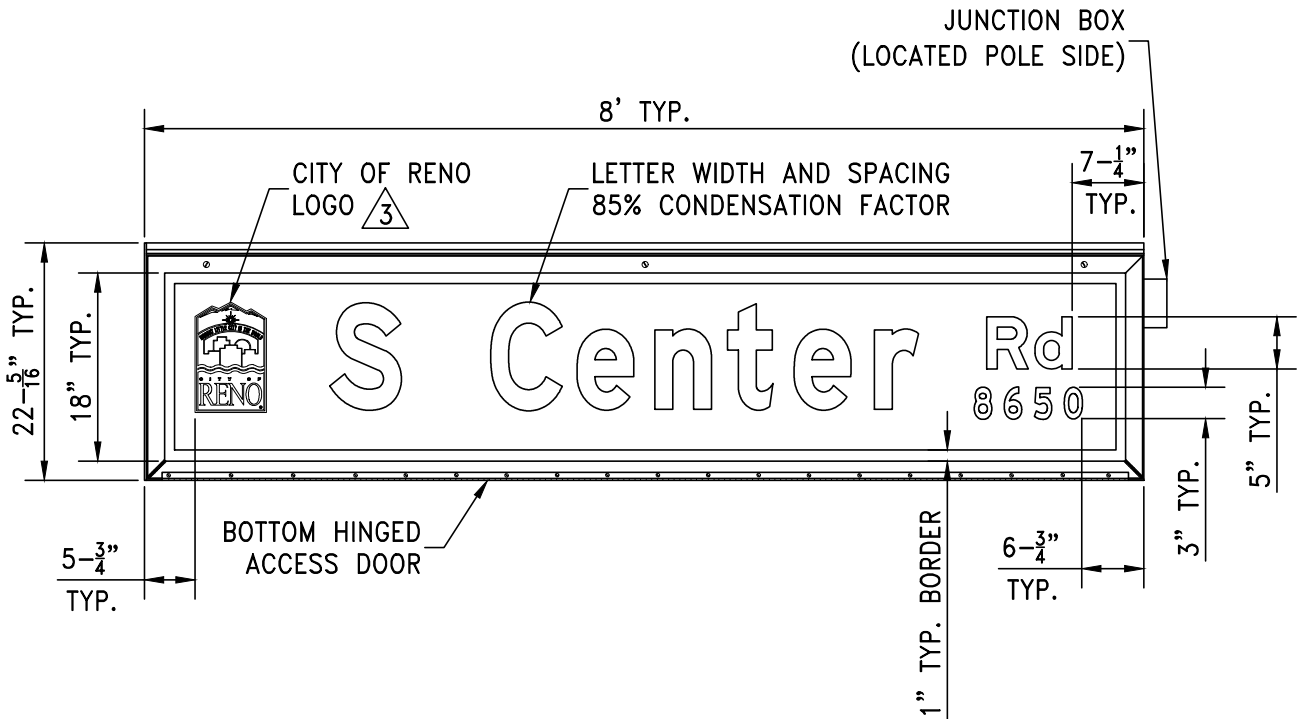

NOTES:

1. THE CITY OF RENO LOGO AND BLOCK NUMBERS SHALL BE PRESENT ON ALL SIGN FACES. SEE IISNS SCHEDULES FOR LEGENDS. ALL STREET NAME SIGNS SHALL BE 8 FOOT DOUBLE FACED WITH CASE SENSITIVE LETTERING. CITY LOGO SHALL BE LOCATED AT THE LEFT SIDE OF THE SIGN.
2. SIGNS SHALL BE WIRED USING 16/3 SOOW OR SJOOW CABLE.
3. LOGO HEIGHT SHALL NOT EXCEED HEIGHT OF UPPERCASE LETTERING. LOGO APPLIQUES ARE NOT ALLOWED.
4. SIGNS SHALL BE MOUNTED TO MAST ARM UNLESS ALTERNATE MOUNTING IS APPROVED BY THE TRAFFIC ENGINEER.
5. FASTENERS AND ASSOCIATED HARDWARE FOR INTERNALLY ILLUMINATED STREET SIGNS SHALL BE STAINLESS STEEL.



STANDARD DETAILS FOR PUBLIC WORKS CONSTRUCTION

DRAWING No.



**POLE STREET
NAME SIGN**

R-413E

APPROVED BY: KK

DATE: 2/2026

CITY OF RENO GENERAL TRAFFIC SIGNAL NOTES

1. IT SHALL BE THE RESPONSIBILITY OF THE CONTRACTOR TO LOCATE ALL EXISTING SUBSTRUCTURES, WHETHER SHOWN OR NOT, AND TO NOTIFY ALL UTILITY COMPANIES TO VERIFY IN THE FIELD THE LOCATION OF THEIR INSTALLATIONS AT LEAST 48 HOURS PRIOR TO CONSTRUCTION. THE CONTRACTOR SHALL PROTECT ALL SUBSTRUCTURES FROM DAMAGE, AS WELL AS ANY OTHER PUBLIC INFRASTRUCTURE. THE EXPENSE TO REPAIR OR FOR REPLACEMENT SHALL BE BORNE BY THE CONTRACTOR.
 2. ALL CONSTRUCTION SHALL BE IN ACCORDANCE WITH THE STANDARD SPECIFICATIONS FOR PUBLIC WORKS CONSTRUCTION (LATEST EDITION) AND THE STANDARD DETAILS FOR PUBLIC WORKS CONSTRUCTION (LATEST EDITION), AND SUPPLEMENTED BY THE NEVADA DEPARTMENT OF TRANSPORTATION PLANS FOR ROAD AND BRIDGE CONSTRUCTION (NDOT SPRBC), LATEST EDITION.
 3. THE LOCATION OF CONTROLLER, PULL BOXES WITH GROUND RODS, AND CONDUIT RUNS SHALL BE WITHIN THE EXISTING RIGHT-OF-WAY OR ANY EASEMENT GRANTED OUTSIDE THE RIGHT-OF-WAY.
 4. DESIGN ENGINEER SHALL BE RESPONSIBLE OF THE LOCATION OF ALL ELECTRICAL, SIGNAL POLE, CONTROLLER, CONDUIT, LOOP DETECTOR, AND PULL BOXES. FINAL LOCATIONS ARE TO BE DETERMINED IN THE FIELD BY THE CONTRACTOR AND ANY CHANGES SHALL BE APPROVED BY TRAFFIC ENGINEER.
 5. CONTROLLERS AND CABINETS SHALL MEET THE REQUIREMENTS OF THE NEMA STANDARD PUBLICATION (LATEST EDITION) AND THE CITY OF RENO SPECIFICATIONS FOR TRAFFIC SIGNAL CONTROLLERS AND CABINETS.
 6. UNLESS SHOWN OTHERWISE, THE CONTROLLER CABINET SHALL BE WIRED FOR EIGHT (8) PHASE OPERATION WITH FOUR (4) OVERLAPS AND SHALL BE FURNISHED WITH ALL NECESSARY MODULES, LOAD SWITCHES, AND EQUIPMENT REQUIRED FOR FULL EIGHT (8) PHASE OPERATION WITH FOUR (4) OVERLAPS.
-  ALL NEW SIGNAL POLES WILL HAVE TWO (2) HANDHOLES AND AN ACCESS DOOR FOR THE TERMINAL BLOCK. SEE TRAFFIC SIGNAL POLE DETAIL DRAWING R-413A FOR TRAFFIC SIGNAL EQUIPMENT DIMENSIONS. FOR OTHER POLE DETAILS, SEE THE NDOT-SPRBC, LATEST EDITION.
8. UNLESS SHOWN OTHERWISE, No. 7 TRAFFIC RATED PULL BOX SHALL BE USED AT LOCATIONS WHERE CONDUIT RUNS CONTAIN TRAFFIC SIGNAL CABLE OR CARRY POWER. ALL PULL BOXES WITH METAL LIDS SHALL BE GROUNDED PER TRAFFIC RATED PULL BOX DETAIL.
 9. ALL EXPOSED CONDUIT SHALL BE OF A RIGID PVC SCHEDULE 80 AND SHALL EXTEND TO A MINIMUM DEPTH OF 18 INCHES. ALL OTHER CONDUIT SHALL BE PVC SCHEDULE 40 MINIMUM.
 10. ALL CONDUIT RUNS FOR SIGNAL CABLE SHALL CONSIST OF TWO 3" CONDUITS BETWEEN PULL BOXES AND BETWEEN THE PULL BOXES AND POLES. THERE SHALL BE THREE 3" CONDUITS FROM THE CONTROLLER CABINET TO THE PULL BOXES. THESE ARE MINIMUM CONDITIONS. REFER TO PLANS FOR ADDITIONAL NEEDS.
 11. ALL CONDUIT RUNS TERMINATING IN A PULL BOX SHALL HAVE A MINIMUM OF SIX INCHES OF CLEARANCE FROM THE BOTTOM OF THE LID, AND SHALL RISE A MINIMUM OF THREE INCHES ABOVE THE TOP OF THE DRAIN ROCK. SEE DETAIL R-412B.
 12. ALL NEW CONDUIT RUNS SHALL HAVE A PULL TAPE.
 13. ALL CONDUIT TERMINATIONS SHALL HAVE A "BELL END" INSTALLATION AND BE SEALED WITH CONDUIT SEALER AFTER WIRE INSTALLATION. CONDUIT ENDS SHALL NOT TERMINATE WITHIN A SWEEP SECTION. ALL CONDUCTORS AND THEIR TERMINATION SHALL BE CLEARLY MARKED ON THE CABINET SCHEMATIC WIRING DIAGRAM.
-  THE RED, YELLOW AND GREEN INDICATION FOR ALL NEW VEHICULAR SIGNAL HEADS SHALL BE 12 INCH LIGHT EMITTING DIODE (LED) AND INCLUDE "AllnGap" TECHNOLOGY. UTILIZE "LEOTEK" OR APPROVED EQUAL. ALL PEDESTRIAN SIGNAL INDICATIONS SHALL BE COUNTDOWN "LED" WITH HAND SYMBOL (PORTLAND ORANGE) AND WALKING MAN SYMBOL (LUNAR WHITE).



STANDARD DETAILS FOR PUBLIC WORKS CONSTRUCTION

DRAWING No.

**NOTES -
TRAFFIC SIGNALS & POLES**

R-413F

APPROVED BY:KK

DATE: 2/2026

15. ALL VEHICULAR HEADS SHALL HAVE "TUNNEL" VISORS WITH 4 INCH SLOT AT BOTTOM WITH LOUVERED BACK PLATES. ALL SIGNAL HEADS TO BE MANUFACTURED BY "ECONOLITE", "EAGLE" OR APPROVED EQUAL. HARDWARE SHALL BE ALUMINUM AND HAVE A BLACK FACTORY FINISH. INSTALL RETROREFLECTIVE BORDER ON BACKPLATES PRIOR TO INSTALLATION. SEE NDOT-SPRBC DETAIL TS-4.
16. ALL NEW PEDESTRIAN PUSH BUTTONS SHALL BE "POLARA INS" 2-WIRE UNLESS OTHERWISE SPECIFIED IN PLANS. SIGNS SHALL BE R10-3E. THE ARROW SHALL POINT IN THE DIRECTION OF THE CROSSING. FOR MOUNTING HEIGHT AND ADDITIONAL DETAILS, SEE NDOT-SPRBC DETAIL TS-14.
17. ALL INTERSECTIONS SHALL HAVE A BATTERY BACK UP SYSTEM. THE SYSTEM SHALL BE MOUNTED TO THE METERED SERVICE CABINET OF THE SYSTEM AND WILL BE A 24 VOLT OR 48 VOLT SYSTEM. THE CABINET SHALL BEAR A 508 UL LABEL. THE SYSTEM SHALL SUPPLY A MINIMUM UNINTERRUPTED CONTINUOUS POWER SUPPLY (UPS) SERVICE FOR UP TO 2 HOURS. THE SYSTEM SHALL FEATURE AN EVENT COUNTER AND TIMER. THE SYSTEM SHALL HAVE A TWO (2) YEAR PARTS AND LABOR TRANSFERABLE WARRANTY TO THE CITY OF RENO. THE UPS UNIT AND THE METERED PEDESTAL SHALL BE DESIGNED AS ONE COMPLETE UNIT. THE UPS SYSTEM SHALL BE A PIGGYBACK DESIGN SYSTEM AND HANG ON THE METERED SERVICE PEDESTAL.
18. WHEN CONTROLLER CABINETS ARE NOT LOCATED IN A SIDEWALK, THEY SHALL HAVE A CONCRETE SERVICE PAD INSTALLED IN FRONT OF THE CABINET, THE SAME WIDTH AS CABINET AND AT LEAST 3 FEET LONG. SEE NDOT-SPRBC DETAIL TS-1. NO IMPROVEMENTS SHALL BE PERMITTED TO BLOCK CABINET DOOR IN COMPLIANCE WITH NEC. SPRINKLER SYSTEMS SHALL BE DIRECTED AWAY FROM AND NOT ALLOWED TO SPRAY CABINET OR PULL BOXES DIRECTLY.
19. ALL NEW TRAFFIC SIGNALS SHALL BE CONNECTED INTO THE CITY OF RENO'S TRAFFIC SIGNAL CENTRAL COMPUTER SYSTEM VIA THE NEAREST RECEIVER SITE BY FIBER-OPTIC OR AN APPROVED OTHER.
20. FOR FIBER OPTIC AND EQUIPMENT CONTACT CITY OF RENO TRAFFIC ENGINEERING FOR LATEST SPECIFICATIONS.
21. THE LUMINAIRE FIXTURES SHALL BE "CREE" GWYL-A-25L-30K7-2M-UL-GY-U-W10-05 OR APPROVED EQUIVALENT. NO SHORTING CAPS. PHOTO CELL TO BE LOCATED IN METERED SERVICE PEDESTAL.
22. PREEMPTION OF SIGNALS BY EMERGENCY VEHICLES SHALL BE PROVIDED BY INSTALLING DUAL CHANNEL OPTICOM MODEL 722, OR AN APPROVED EQUAL.
23. THE CONTRACTOR SHALL PROVIDE AN UNDERGROUND SERVICE PEDESTAL. THE MAIN BREAKER SHALL BE 100 AMP MINIMUM (120/240 VAC, 60 HZ, SINGLE PHASE, 3 WIRE) IN ACCORDANCE WITH NDOT-SPRBC DETAIL TG-2. INDIVIDUAL CIRCUIT BREAKERS SHALL INCLUDE 120 VOLT: 30 AMP 1-POLE CIRCUIT BREAKER FOR SIGNAL; 30 AMP 2-POLE CIRCUIT BREAKER FOR LIGHTING CONTACTOR; 20 AMP 1-POLE CIRCUIT BREAKER FOR STREET LIGHTS; 20 AMP 1-POLE CIRCUIT BREAKER FOR SIGNS; 15 AMP 1-POLE CIRCUIT BREAKER FOR CONTROL; AND A 15 AMP 1-POLE CIRCUIT BREAKER FOR GFI RECEPTACLE, UNLESS OTHERWISE NOTED IN THE PLANS. THE CONDUCTOR TO THE CABINET FROM THE BREAKER SHALL BE A MINIMUM OF 10 GAUGE WIRE.
24. THE CONTRACTOR SHALL COORDINATE WITH NV ENERGY IN PROVIDING SERVICE FOR THE SIGNAL WITHIN NV ENERGY STANDARDS.
25. POWER PANEL SURGE PROTECTION SHALL BE PROVIDED AND APPROVED THROUGH THE SUBMITTAL PROCESS TO THE PUBLIC WORKS TRAFFIC ENGINEERING DIVISION.
26. NO SPLICES SHALL BE PERMITTED BETWEEN THE CONTROLLER CABINET AND THE TRAFFIC SIGNAL POLE. ALL CONNECTIONS SHALL BE MADE AT THE JUNCTION BOX, OR IN THE CASE OF LOOPS, AT THE LOOP STUB. ANY DEVIATION TO THIS REQUIREMENT SHALL BE APPROVED BY THE TRAFFIC ENGINEER PRIOR TO THE WORK.



STANDARD DETAILS FOR PUBLIC WORKS CONSTRUCTION

DRAWING No.

NOTES -
TRAFFIC SIGNALS & POLES

R-413G

APPROVED BY: KK | DATE: 2/2026

27. IF ANY PAVEMENT MARKINGS ARE TO BE RELOCATED, VEHICLE DETECTOR LOOPS SHALL BE RELOCATED ACCORDINGLY TO REMAIN CONSISTENT WITH CITY OF RENO STANDARD DETAIL NO. R-406A, R-406B AND R-406C.
28. AS A PART OF ANY STREET WIDENING PROJECT OR THE ADDITION OF ANY STREET TRAVEL LANES TO EXISTING LANES, SUCH AS TURN LANES, ACCELERATION OR DECELERATION LANES, ETC., THE CONTRACTOR MUST EXTEND ANY TRAFFIC CONTROL CONDUITS AND/OR WIRING AND REPLACE ALL AFFECTED VEHICLE LOOP DETECTOR WIRING (SPlicing SHALL NOT BE ALLOWED).
29. SIGNAL EQUIPMENT SHALL BE PROVIDED AND APPROVED THROUGH THE SUBMITTAL PROCESS TO THE PUBLIC WORKS TRAFFIC ENGINEERING DIVISION AT TRAFFICSIGNALS@RENO.GOV.
30. FOR POLE DETAILS NOT SHOWN, SEE POLE MANUFACTURER'S DETAILED DRAWINGS.
31. ALL SIGNAL POLES AND FOUNDATIONS SHALL CONFORM TO NDOT TYPE 35 AND 35A SPECIFICATIONS, INCLUDING BOLT CIRCLE DIMENSIONS, ANCHOR BOLTS, AND FOOTING DIMENSIONS.
32. FINAL POLE APPROVAL AND SUBMITTALS TO BE APPROVED BY THE CITY OF RENO.
33. CLAM SHELL FOR TYPE 7D POLE TO BE USED ONLY WHEN POLE IS INCLUDED AS A SIGNAL POLE. DO NOT USE CLAM SHELL WHEN TYPE 7D POLE IS USED IN SERIES LIGHTING.
34. POLE MAY BE MANUFACTURED AS EITHER A DOUBLE OF SINGLE CANDYCANES CONFIGURATION.
35. VIDEO DETECTION MAY BE USED IF APPROVED BY THE CITY TRAFFIC ENGINEER.
36. ALL EQUIPMENT SHALL BE IN ACCORDANCE WITH CITY OF RENO "TRAFFIC SIGNAL CONTROLLER CABINET SPECIFICATIONS" AND CITY OF RENO "TRAFFIC SIGNAL FIBER OPTIC INTERCONNECT SPECIFICATIONS" EXCEPT AS SPECIFICALLY MODIFIED IN THESE PLANS. NEW CONTROLLER ASSEMBLIES SHALL INCLUDE ALL SIGNAL CONTROLLER EQUIPMENT AS REQUIRED BY THE CITY'S EQUIPMENT SPECIFICATIONS.
37. SIGNAL TURN-ONS SHALL BE SCHEDULED BETWEEN 5:00 AM AND 4:00 PM ON MONDAY THROUGH THURSDAY. COORDINATE WITH CITY OF RENO SIGNAL TECHNICIANS.
38. 1/4"-20 BOLTS WITH LOCK WASHERS AND FLAT WASHERS ARE REQUIRED FOR ALL HAND HOLE AND BASE PLATE COVERS.
39. SIGNAL SHUTDOWNS WILL ONLY BE PERMITTED FROM 9:00 PM TO 5:00 AM IN THE CITY OF RENO, UNLESS OTHERWISE APPROVED FOLLOWING WRITTEN REQUEST.
40. ALL SIGNAL EQUIPMENT, HARDWARE, UNBROKEN PULL BOX LIDS, AND SIGNS REMOVED THROUGH THE COURSE OF WORK SHALL BE DELIVERED TO THE CITY OF RENO'S CORPORATE YARD.



STANDARD DETAILS FOR PUBLIC WORKS CONSTRUCTION

DRAWING No.

**NOTES -
TRAFFIC SIGNALS & POLES**

R-413H

APPROVED BY: KK

DATE: 2/2026

41. THE CONTRACTOR SHALL COORDINATE TRAFFIC SIGNAL INSTALLATIONS OR MODIFICATIONS WITH THE CITY OF RENO TRAFFIC TEAMS AT TRAFFICSIGNALS@RENO.GOV AT LEAST TWO WORKING DAYS PRIOR TO WORK. DURING WORKING HOURS, CALL 775-334-2243. FOR AFTER HOURS OR EMERGENCIES, CALL 775-772-3151.
42. PROGRAMMING OF CONTROLLERS AND MMU's WILL BE PERFORMED BY CITY OF RENO STAFF ONLY. DELIVER CONTROLLERS AND MMU's TO CITY OF RENO TRAFFIC ENGINEERING & OPERATIONS AT 1640 EAST COMMERCIAL ROW, RENO, NV AT LEAST TWENTY-ONE (21) DAYS PRIOR TO SIGNAL TURN-ON. CONTACT TRAFFIC SIGNALS SUPERVISOR AT 775-334-2240 AT LEAST SEVEN (7) DAYS PRIOR TO DESIRED PICK-UP FOR INSTALLATION.
43. NOTIFY THE CITY OF RENO, TRAFFIC ENGINEER 775-433-5094 AND CITY OF RENO SIGNAL TECHNICIANS (WORKING HOURS: 775-334-2243, AFTER HOURS OR EMERGENCY: 775-772-3151), AT LEAST 72 HOURS PRIOR TO SIGNAL TURN-ONS. NO MORE THAN TWO (2) SIGNAL TURN-ONS WILL BE ALLOWED PER DAY.



STANDARD DETAILS FOR PUBLIC WORKS CONSTRUCTION

DRAWING No.

**NOTES -
TRAFFIC SIGNALS & POLES**

R-413I

APPROVED BY: KK

DATE: 2/2026

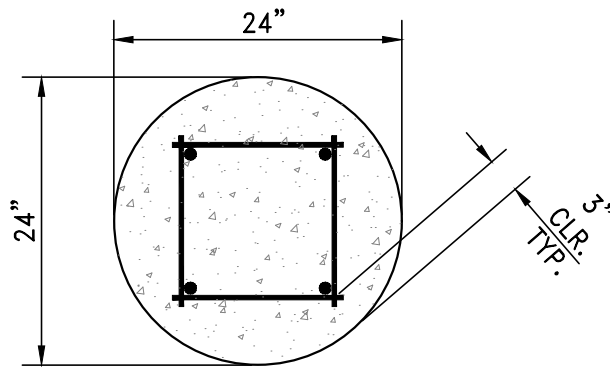

SECTION A-A

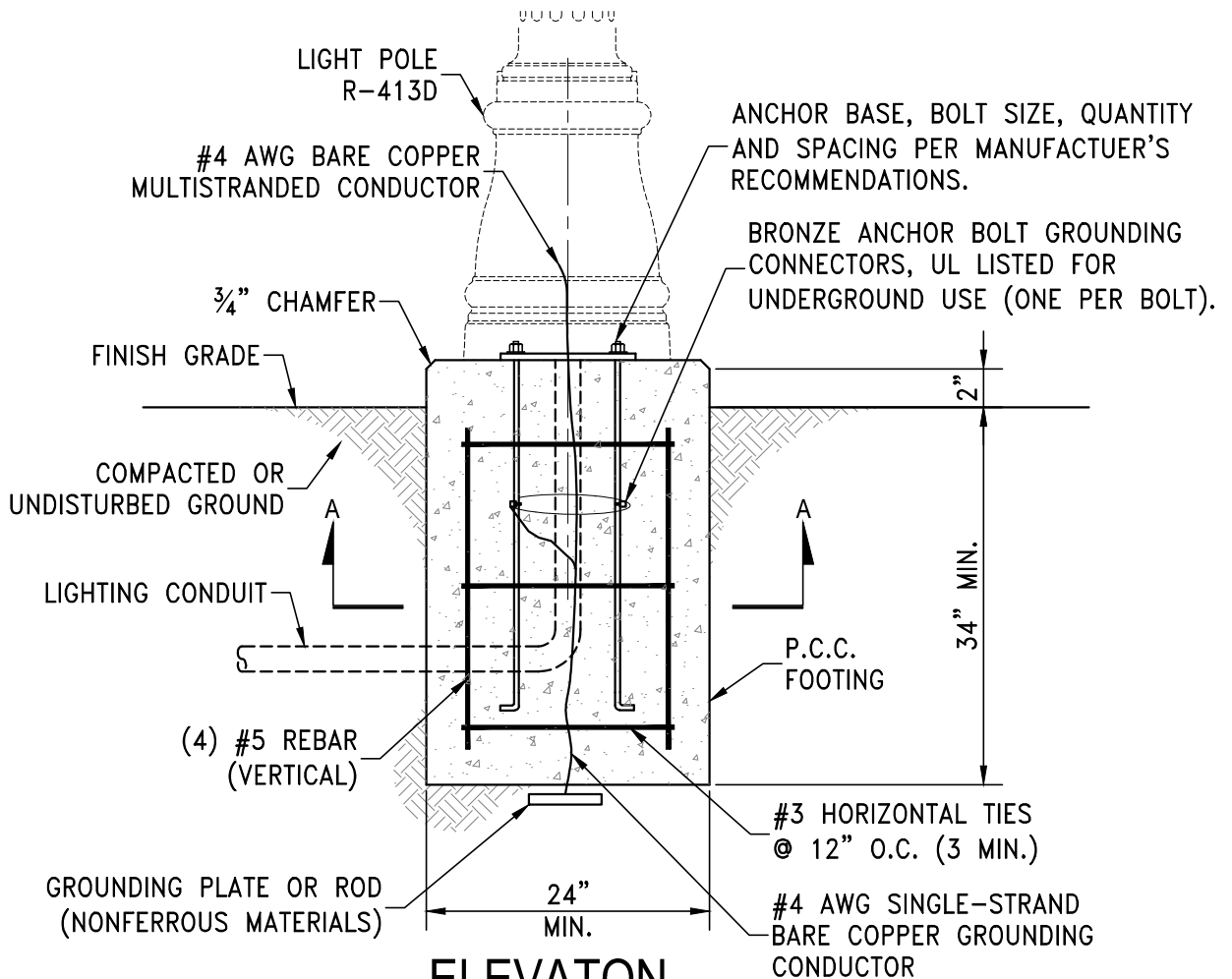

ELEVATION

NOTES:

1. PORTLAND CEMENT CONCRETE (P.C.C.) SHALL BE 4000 PSI MIN. COMPRESSIVE STRENGTH AT 28 DAYS. ALL CEMENT CONCRETE SHALL HAVE A COARSE AGGREGATE GRADATION CONFORMING TO SIZE No. 67. POLYPROPYLENE OR CELLULOSE FIBERS SHALL BE ADDED TO THE P.C.C. AT 1.5 LBS PER CUBIC YARD. MIX DESIGN SHALL CONFORM TO THE REQUIREMENTS OF SECTION 337.10 OF SSPWC. ALL MATERIALS SHALL CONFORM TO SSPWC.



STANDARD DETAILS FOR PUBLIC WORKS CONSTRUCTION

DRAWING No.

LIGHT POLE FOOTING

R-413J

APPROVED BY:KK

DATE: 2/2026



R7-106
12"x18"



R7-1 MODIFIED
12"x18" 



R7-8 MODIFIED
12"x18" 





R7-9
12"x18"



R7-108
12"x18" 

NOTES:

1. SIGN LETTERS, COLORS AND PLACEMENT SHALL BE IN CONFORMANCE WITH THE LATEST EDITION OF THE MANUAL ON UNIFORM TRAFFIC CONTROL DEVICES (MUTCD).
-  TIME RESTRICTED PARKING SIGNS ARE AVAILABLE IN 30 MINUTE, 1 HOUR, 2 HOUR, AND 5 HOUR INCREMENTS.
3. REFER TO STANDARD DETAIL DRAWING NO. R-415 FOR MOUNTING AND POLE REQUIREMENTS, UNLESS OTHERWISE SPECIFIED.
-  MODIFIED TO CONFORM TO RENO MUNICIPAL CODE SECTION 6.30.470.
-  MODIFIED TO CONFORM TO RENO MUNICIPAL CODE SECTION 6.30.400.
6. ALL SIGNS SHALL BE 3M DIAMOND GRADE (DG3), SERIES 4000, SHEETING WITH A CLEAR, TRANSPARENT OVERLAY 3M #1160i (LATEST EDITION) OR APPROVED EQUAL. SHALL BE A MATCHED COMPONENT SYSTEM.
7. OVERLAY ACRYLIC EC FILMS, INKS AND DIGITAL IMAGING USED FOR ASSEMBLY SHALL BE APPROVED FOR USE BY THE MANUFACTURER OF THE SHEETING MATERIAL. THE SERVICE LIFE OF INKS AND FILMS SHALL BE COMPARABLE TO THE SHEETING USED. ALL LETTERS, NUMERALS, SYMBOLS, BORDERS, AND ACCESSORIES AS NECESSARY FOR THE SIGN LEGEND SHALL BE DIRECTLY APPLIED, DIGITALLY PRINTED, OR MOLDED TO FORM AN INTEGRAL SIGN LEGEND AND BACKGROUND ON ALL SIGNS.



STANDARD DETAILS FOR PUBLIC WORKS CONSTRUCTION

DRAWING No.

TRAFFIC PARKING SIGNS

R-414

APPROVED BY: KK | DATE: 2/2026

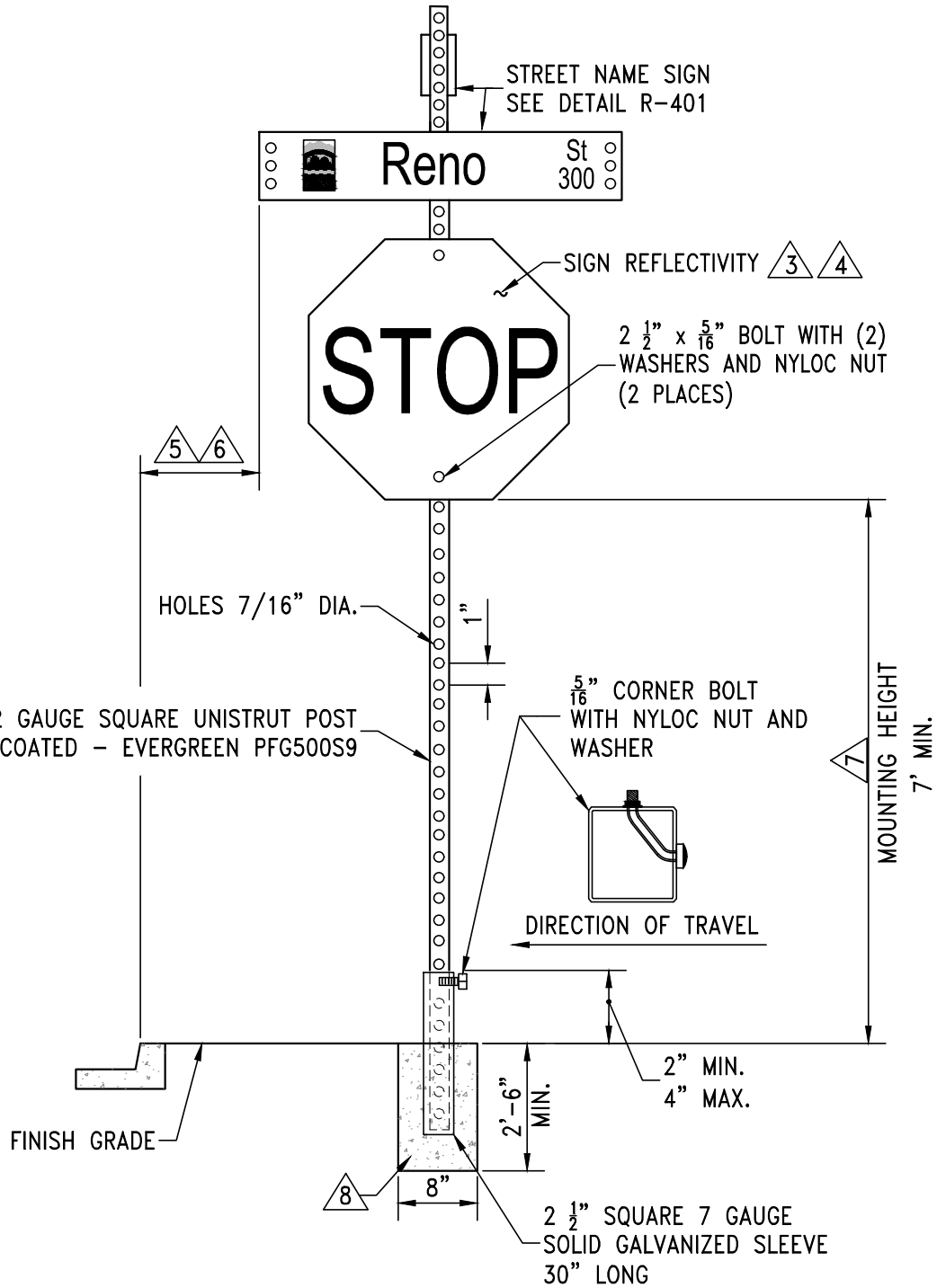

STANDARD DETAILS FOR PUBLIC WORKS CONSTRUCTION

DRAWING No.

TRAFFIC SIGN INSTALLATION

R-415A

APPROVED BY: KK

DATE: 2/2026

NOTES:

1. SIGN MATERIALS, CONSTRUCTION AND PLACEMENT SHALL BE IN CONFORMANCE WITH THE LATEST EDITION OF THE MANUAL ON UNIFORM TRAFFIC CONTROL DEVICES.
2. CONCRETE BASE SHALL BE LOCATED AT BACK OF SIDEWALK, UNLESS OTHERWISE DIRECTED BY THE CITY ENGINEER.
3. ALL SIGNS SHALL BE 3M DIAMOND GRADE (DG3), SERIES 4000, SHEETING WITH A CLEAR, TRANSPARENT OVERLAY 3M #1160i (LATEST EDITION) OR APPROVED EQUAL. SHALL BE A MATCHED COMPONENT SYSTEM.
4. OVERLAY ACRYLIC EC FILMS, INKS AND DIGITAL IMAGING USED FOR ASSEMBLY SHALL BE APPROVED FOR USE BY THE MANUFACTURER OF THE SHEETING MATERIAL. THE SERVICE LIFE OF INKS AND FILMS SHALL BE COMPARABLE TO THE SHEETING USED. ALL LETTERS, NUMERALS, SYMBOLS, BORDERS, AND ACCESSORIES AS NECESSARY FOR THE SIGN LEGEND SHALL BE DIRECTLY APPLIED, DIGITALLY PRINTED, OR MOLDED TO FORM AN INTEGRAL SIGN LEGEND AND BACKGROUND ON ALL SIGNS.
5. 2 FEET MINIMUM FROM EDGE OF SIGN TO FACE OF CURB.
6. 6 FEET MINIMUM FROM EDGE OF SIGN TO EDGE OF PAVEMENT WHERE CURB DOES NOT EXIST.
7. SIGN MOUNTING HEIGHT SHALL BE 7 FEET FROM FINISHED GRADE OR ADJACENT ROADWAY PAVEMENT IF NOT BEHIND CURB.
8. FOUNDATION SHALL BE 4000 PSI CONCRETE.



STANDARD DETAILS FOR PUBLIC WORKS CONSTRUCTION

DRAWING No.

NOTES - TRAFFIC SIGN INSTALLATION

R-415B

APPROVED BY: KK

DATE: 2/2026

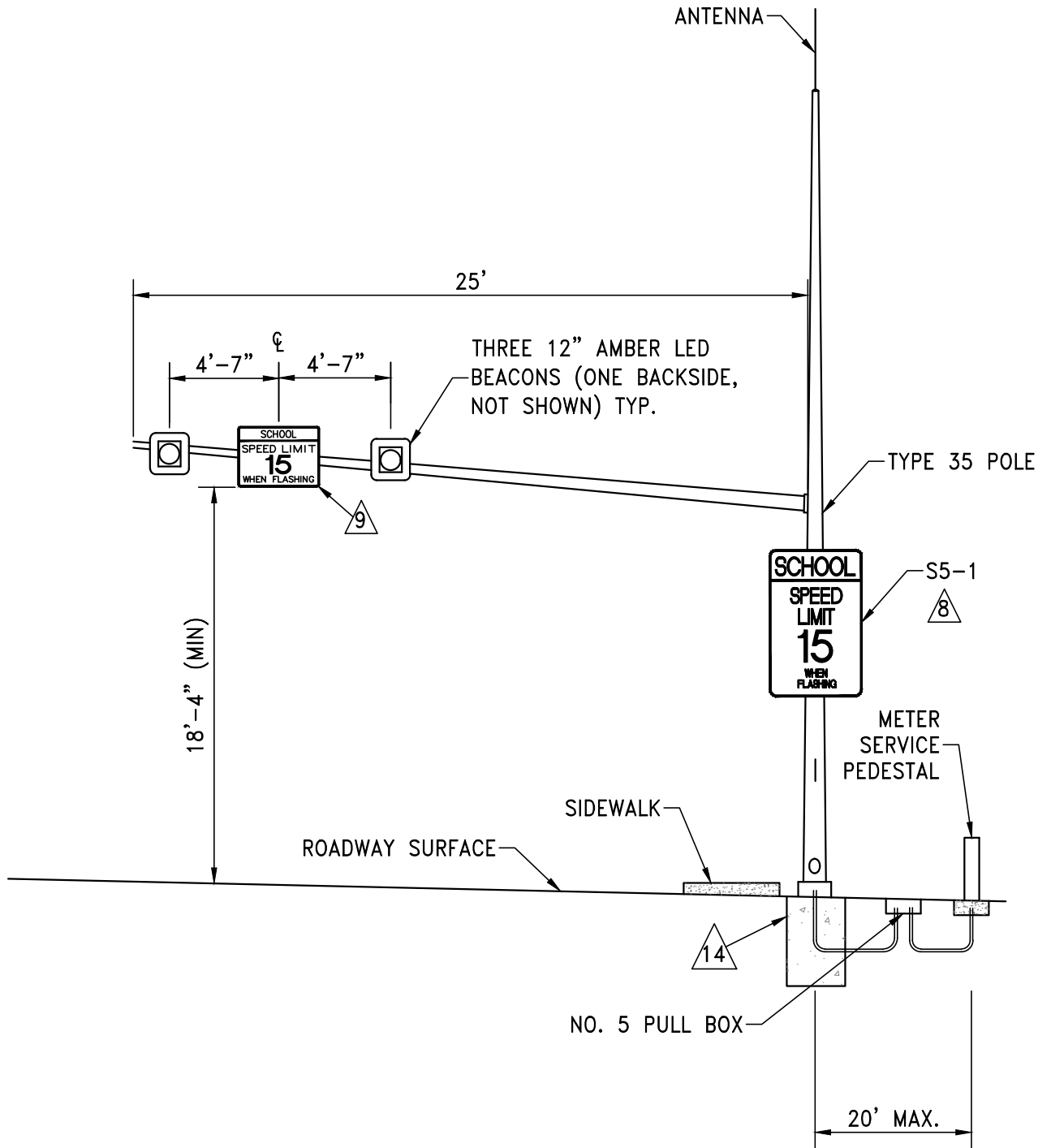

STANDARD DETAILS FOR PUBLIC WORKS CONSTRUCTION

SCHOOL ZONE FLASHERS - OVERHEAD



DRAWING No.

R-417A

APPROVED BY: KK

DATE: 2/2026

NOTES:

1. YELLOW POLYCARBONATE SINGLE HEADS.
2. ALL PIPING SHALL BE YELLOW IN ALUMINUM OR BRASS, INCLUDING END OF MAST RIGID FITTING.
3. YELLOW TUNNEL VISORS POLYCARBONATE.
4. SINGLE HEAD BACKPLATES FOR ALL HEADS TO BE 1 PIECE, BLACK POLYCARBONATE.
5. HEADS EITHER TENON MOUNT OR END OF MAST 2 WAY CROSS TOP HUNG.
6. ALL SIGNS SHALL COMPLY WITH THE MUTCD, LATEST EDITION.
7. SIGN FOR MAST ARM SHALL BE MIN. 30" X 24" ATTACHED TO ARM WITH BRACKETS.
8.  S5-1 SIGN FOR POLE MOUNT SHALL BE MINIMUM 24" X 48" MOUNTED DIRECTLY TO POLE USING 4 BOLTS AND 1 BRACKET.
9.  SIGN FOR MAST ARM "END SCHOOL ZONE" SHALL BE 24" X 30" AND MOUNTED DIRECTLY BEHIND MAST ARM "SCHOOL ZONE" SIGN WITH BRACKET.
10. SCHOOL ZONE FLASHER CONTROLLER SYSTEM: CABINET, CONTROLLER, TIME SWITCH AND TIME SWITCH CONVERTOR SHALL BE RTC MANUFACTURING, INC. OTHER SPECIFIED MODELS SHALL REQUIRE APPROVAL OF THE CITY'S TRAFFIC ENGINEER.
 - A. RTC MANUFACTURING, INC. ONE-BATTERY SYSTEM INCLUDING GUARDIAN PANEL NO. 2 CABINET (PART# 502565K), "SCHOOL ZONE FLASHER SYSTEM" APPLICATION.
 - B. RTC MANUFACTURING, INC. AP22 TIME SWITCH.
 - C. M2M CELLULAR MODEM.
11. YELLOW LED'S SHALL BE "LEOTEK" OR APPROVED EQUAL.
12. SERVICE TO BE A TYPE 3R TESCO 26-100 OR BETTER WITH BRUSHED ALUMINUM FINISH, RTC MODEL NO. 502565K, OR APPROVED EQUAL, TO BE MOUNTED AT TOP OF THE POWER DISTRIBUTION PANEL.
13. ALL EQUIPMENT SHALL BE WITHIN THE CITY OF RENO RIGHT-OF-WAY OR EASEMENT WITH POLE LOCATED BEHIND SIDEWALK. POLE, SIGN AND EQUIPMENT LOCATION SHALL BE PLACED TO CONFORM TO THE REQUIREMENTS OF PROWAG. TYPICAL POLE PLACEMENT SHALL BE THE BACK OF SIDEWALK. WHERE NO SIDEWALK EXIST ALL EQUIPMENT SHALL BE 2' MIN. CLEAR FROM THE ROADWAY FACE OF CURB.
14.  SEE NDOT STANDARD PLANS FOR ROAD AND BRIDGE CONSTRUCTION TYPE 30 OR TYPE 35 FOR POLE AND BASE DETAILS.
15. MAST ARMS MAY BE DELETED FOR ONE-LANE EACH DIRECTION ROADWAYS.
16. TESTED AND PROVEN OPERATIONAL BEFORE CITY ACCEPTANCE.
17. ALL EQUIPMENT SHALL BE SUBMITTED FOR TO THE CITY'S TRAFFIC ENGINEER FOR REVIEW AND APPROVAL PRIOR TO CONSTRUCTION. AFTER INSTALLATION, SCHOOL ZONE FLASHER SHALL BE FIELD TESTED IN THE PRESENCE OF THE TRAFFIC ENGINEER (OR DESIGNEE) AND PROVEN OPERATIONAL TO THE SATISFACTION OF THE CITY BEFORE FINAL CITY ACCEPTANCE.



STANDARD DETAILS FOR PUBLIC WORKS CONSTRUCTION

DRAWING No.

NOTES -
SCHOOL ZONE FLASHERS - OVERHEAD

R-417B

APPROVED BY: KK DATE: 2/2026

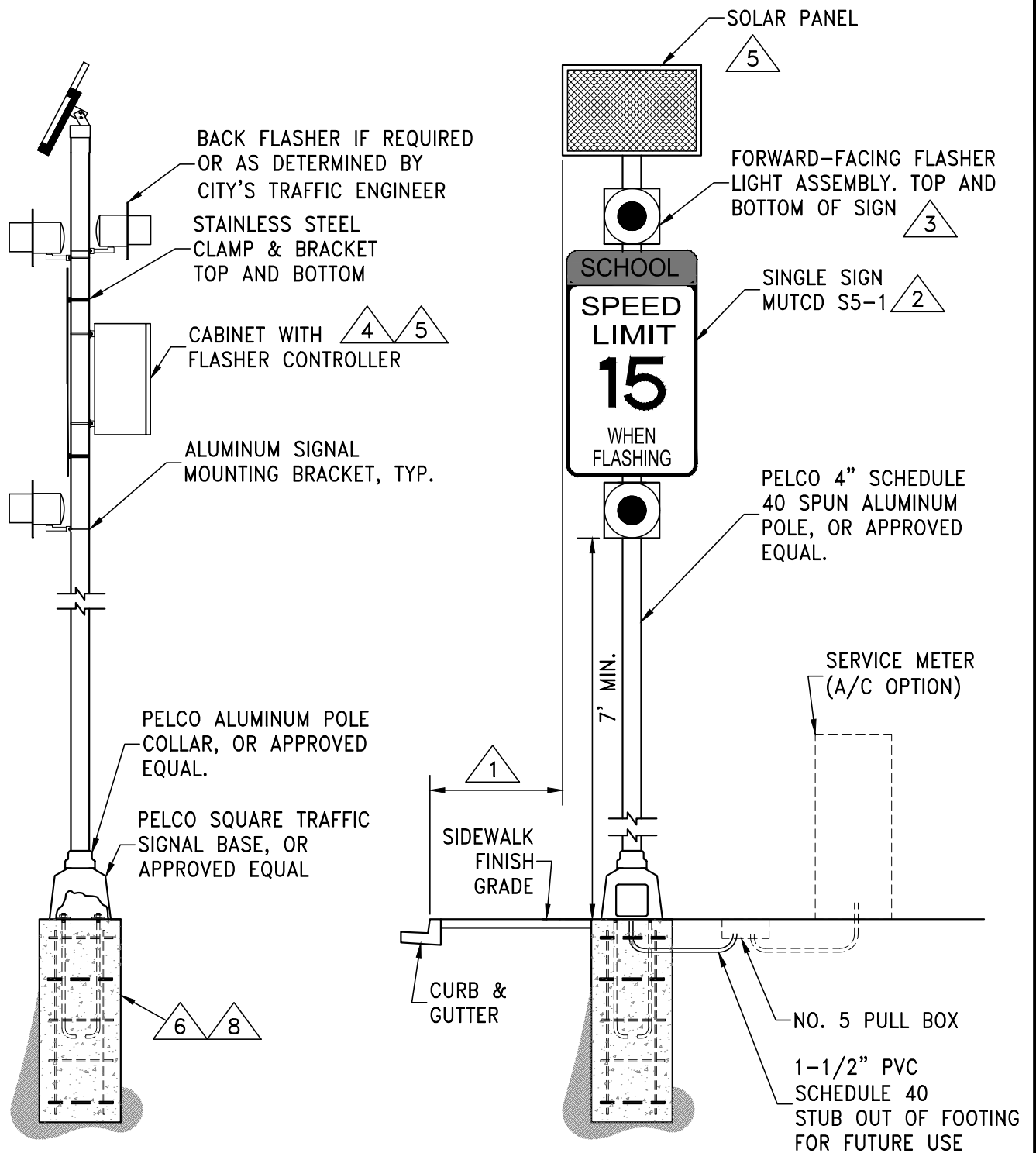

SIDE ELEVATION

FRONT ELEVATION



STANDARD DETAILS FOR PUBLIC WORKS CONSTRUCTION

DRAWING No.

SCHOOL ZONE FLASHERS - ROADSIDE

R-417C

APPROVED BY: KK | DATE: 2/2026

NOTES:

1. ALL EQUIPMENT SHALL BE WITHIN THE CITY OF RENO RIGHT-OF-WAY OR EASEMENT WITH POLE LOCATED BEHIND SIDEWALK. POLE, SIGN AND EQUIPMENT LOCATION SHALL BE PLACED TO CONFORM TO THE REQUIREMENTS OF PROWAG. TYPICAL POLE PLACEMENT SHALL BE THE BACK OF SIDEWALK. WHERE NO SIDEWALK EXIST ALL EQUIPMENT SHALL BE 2' MIN. CLEAR FROM THE ROADWAY FACE OF CURB.
2. ALL SIGNS SHALL CONFORM TO THE MUTCD, LATEST EDITION.
3. FLASHER LIGHTS ASSEMBLY SHALL BE 12" YELLOW LED SINGLE INDICATION PLACED IN A YELLOW POLYCARBONATE TRAFFIC SIGNAL HOUSING WITH A SINGLE-SECTION 1-PIECE BLACK POLYCARBONATE BACKPLATE AND BLACK POLYCARBONATE TUNNEL VISORS.
4. SCHOOL ZONE FLASHER CONTROLLER SYSTEM: CABINET, CONTROLLER, TIME SWITCH AND TIME SWITCH CONVERTOR SHALL BE RTC MANUFACTURING, INC. OTHER SPECIFIED MODELS SHALL REQUIRE APPROVAL OF THE CITY'S TRAFFIC ENGINEER.
 - A. RTC MANUFACTURING, INC. ONE-BATTERY SYSTEM INCLUDING GUARDIAN PANEL NO. 2 CABINET (PART# 503333GK), "SCHOOL ZONE FLASHER SYSTEM" APPLICATION.
 - B. RTC MANUFACTURING, INC. AP22 TIME SWITCH.
 - C. M2M CELLULAR MODEM.
5. SUNSAVER SOLAR CONTROLLER (SS-20L-12V) WITH 65 WATT BATTERY. SOLAR PANEL SIZE BASED ON FIELD CONDITIONS BUT SHOULD BE SIZED SO THE BATTERY STATE OF CHARGE WILL NOT FALL BELOW 90% CAPACITY DURING ANY MONTH OF THE YEAR. SOLAR PANEL EDGE SHALL BE 2' MIN. CLEAR FROM THE ROADWAY FACE OF CURB AND A MAXIMUM WEIGHT OF 30 POUNDS.
6. POLE BASE FOOTING SHALL CONFORM TO NDOT STANDARD PLANS FOR ROADWAY AND BRIDGE CONSTRUCTION, LATEST EDITION. DETAIL TL-2 TYPE 7 FOUNDATION. ANCHOR BOLT SIZE AND DEPTH PER POLE BASE MANUFACTURER.
7. ALL EQUIPMENT SHALL BE SUBMITTED FOR TO THE CITY'S TRAFFIC ENGINEER FOR REVIEW AND APPROVAL PRIOR TO CONSTRUCTION. AFTER INSTALLATION, SCHOOL ZONE FLASHER SHALL BE FIELD TESTED IN THE PRESENCE OF THE TRAFFIC ENGINEER (OR DESIGNEE) AND PROVEN OPERATIONAL TO THE SATISFACTION OF THE CITY BEFORE FINAL CITY ACCEPTANCE.
8. PORTLAND CEMENT CONCRETE (P.C.C.) SHALL BE 4000 PSI MIN. COMPRESSIVE STRENGTH AT 28 DAYS. ALL CEMENT CONCRETE SHALL HAVE A COARSE AGGREGATE GRADATION CONFORMING TO SIZE No. 67. POLYPROPYLENE OR CELLULOSE FIBERS SHALL BE ADDED TO THE P.C.C. AT 1.5 LBS PER CUBIC YARD. MIX DESIGN SHALL CONFORM TO THE REQUIREMENTS OF SECTION 337.10 OF SSPWC. ALL MATERIALS SHALL CONFORM TO SSPWC.



STANDARD DETAILS FOR PUBLIC WORKS CONSTRUCTION

DRAWING No.

NOTES -
SCHOOL ZONE FLASHERS - ROADSIDE

R-417D

APPROVED BY: KK | DATE:2/2026

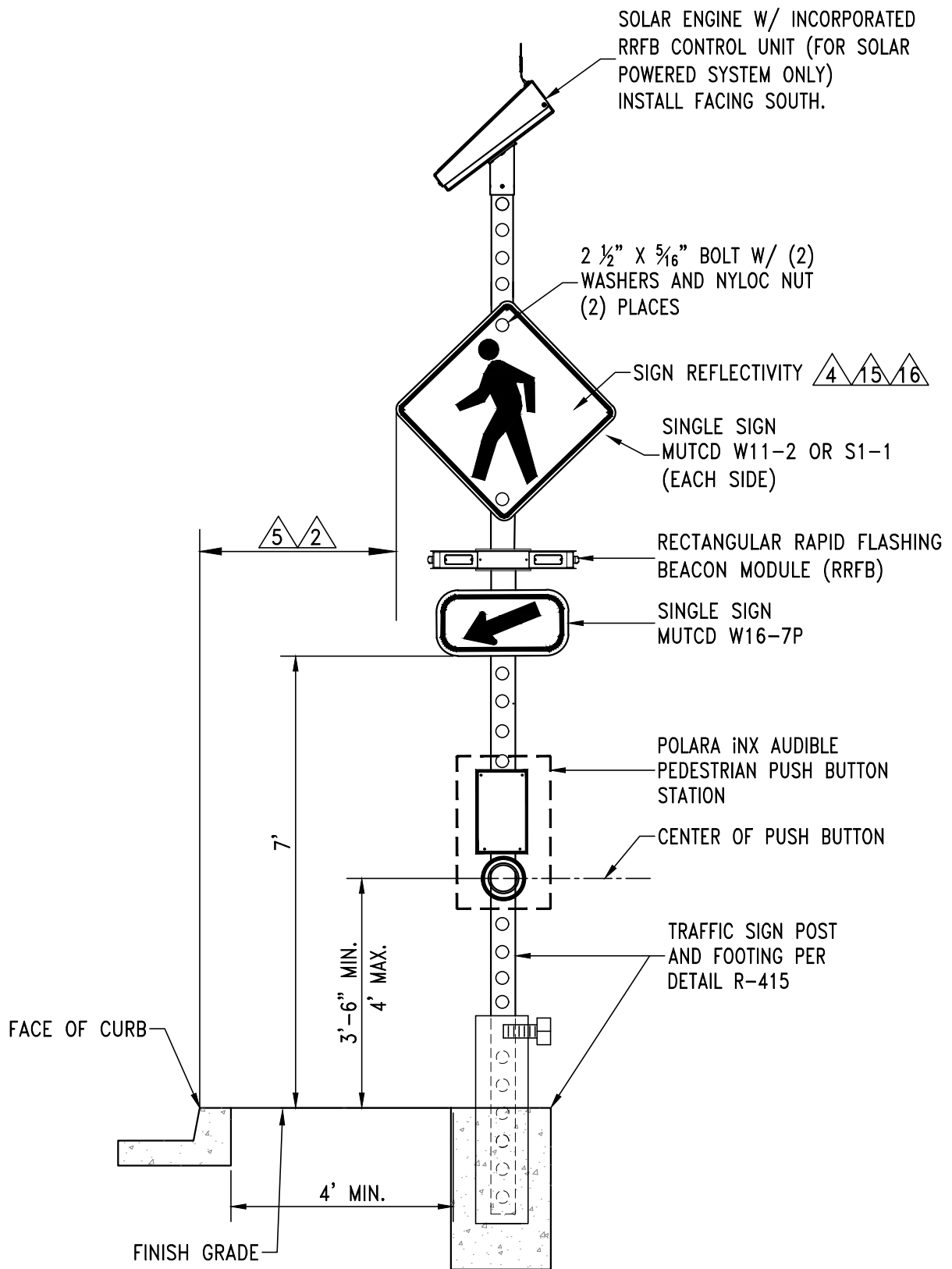

STANDARD DETAILS FOR PUBLIC WORKS CONSTRUCTION

DRAWING No.

POST MOUNTED RECTANGULAR
RAPID FLASHING BEACON (RRFB)

R-417E

APPROVED BY: KK

DATE: 2/2026

NOTES:

1. SIGN MATERIALS, CONSTRUCTION AND PLACEMENT SHALL BE IN CONFORMANCE WITH THE LATEST EDITION OF THE MANUAL ON UNIFORM TRAFFIC CONTROL DEVICES.
2. ON STREETS WHERE CURBING DOES NOT EXIST, SET SIGN 6' MINIMUM FROM PAVEMENT EDGE.
3. CONCRETE BASE SHALL BE LOCATED AT BACK OF SIDEWALK, UNLESS OTHERWISE DIRECTED BY THE CITY TRAFFIC ENGINEER.
4. ALL SIGNS SHALL BE 3M DIAMOND GRADE (DG3), SERIES 4000, SHEETING WITH A CLEAR, TRANSPARENT OVERLAY 3M #1160i (LATEST EDITION) OR APPROVED EQUAL. SHALL BE A MATCHED COMPONENT SYSTEM.
5. 2 FOOT MINIMUM FROM EDGE OF SIGN TO FACE OF CURB, WHERE CURB EXISTS.
6. PEDESTRIAN ACTIVATED RECTANGULAR RAPID FLASHING BEACONS (RRFB) SHALL BE CARMANAH R920-MX AC OR SOLAR SERIES OR APPROVED EQUAL. CONTROLLER SHALL HAVE A MINIMUM OF 4 PROGRAMMABLE RADIO CHANNELS.
7. RRFB MUST INCLUDE A PEDESTRIAN INDICATION SIDE FLASHER THAT FACES CROSSWALK.
8. RRFB SHALL INCLUDE ALL EQUIPMENT AND MATERIALS NECESSARY TO PROVIDE A FULLY FUNCTIONAL SYSTEM PER MANUFACTURER'S RECOMMENDATIONS.
9. RRFB FLASH PATTERN SHALL BE COMPLIANT WITH MUTCD, LATEST EDITION, SECTION 4L.03.
10. ALL NEW PEDESTRIAN PUSH BUTTONS FOR TRAFFIC SIGNALS SHALL BE 2" DIAMETER. UTILIZE POLARA INX AUDIBLE MID-BLOCK CROSSING PUSH BUTTON STATION SYSTEM OR APPROVED EQUAL. THE COLOR OF THE STATION SHOULD BE YELLOW. PEDESTRIAN PUSH BUTTONS LOCATED IN THE CENTER MEDIAN ISLANDS SHALL HAVE A BI-DIRECTIONAL ARROW. NEW PUSH BUTTON STATIONS SHALL HAVE MUTCD R10-25 SIGNS. THE TACTILE ARROW SHALL POINT IN THE DIRECTION OF THE CROSSING AND THE SIGN SHALL BE ALIGNED WITH THE CROSSWALK.
11. LOCATION OF PEDESTRIAN PUSH BUTTONS SHALL BE ADA ACCESSIBLE AND MOUNTED NO MORE THAN 10" FROM A FLAT, ACCESSIBLE LANDING SPACE ($\leq 2\%$). SEE MUTCD, LATEST EDITION.
12. AUDIBLE INFORMATION DEVICES (AID) SHALL PROVIDE A LOCATOR TONE, SHALL NOT USE VIBROTACTILE INDICATIONS OR PERUSSIVE INDICATIONS. THE MESSAGE "WARNING LIGHTS ARE FLASHING" SHALL BE SPOKEN TWICE.
13. ALL EQUIPMENT SHALL BE SUBMITTED FOR TO THE CITY'S TRAFFIC ENGINEER FOR REVIEW AND APPROVAL PRIOR TO CONSTRUCTION. AFTER INSTALLATION, FLASHER SHALL BE FIELD TESTED IN THE PRESENCE OF THE TRAFFIC ENGINEER (OR DESIGNEE) AND PROVEN OPERATIONAL TO THE SATISFACTION OF THE CITY BEFORE FINAL CITY ACCEPTANCE.
14. POST MOUNTED RRFB MAY BE INSTALLED ON SINGLE LANE EACH DIRECTION ROADWAYS OR AS APPROVED BY THE CITY ENGINEER.
15. FLUORESCENT YELLOW-GREEN BACKGROUND SHALL ONLY BE USED FOR SCHOOL ZONES, SCHOOL CROSSINGS, OR PEDESTRIAN SAFETY ZONES.
16. OVERLAY ACRYLIC EC FILMS, INKS AND DIGITAL IMAGING USED FOR ASSEMBLY SHALL BE APPROVED FOR USE BY THE MANUFACTURER OF THE SHEETING MATERIAL. THE SERVICE LIFE OF INKS AND FILMS SHALL BE COMPARABLE TO THE SHEETING USED. ALL LETTERS, NUMERALS, SYMBOLS, BORDERS, AND ACCESSORIES AS NECESSARY FOR THE SIGN LEGEND SHALL BE DIRECTLY APPLIED, DIGITALLY PRINTED, OR MOLDED TO FORM AN INTEGRAL SIGN LEGEND AND BACKGROUND ON ALL SIGNS.



STANDARD DETAILS FOR PUBLIC WORKS CONSTRUCTION

DRAWING No.

NOTES - POST MOUNTED RECTANGULAR
RAPID FLASHING BEACON (RRFB)

R-417F

APPROVED BY: KK

DATE: 2/2026

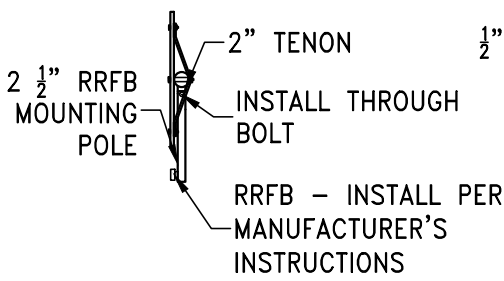
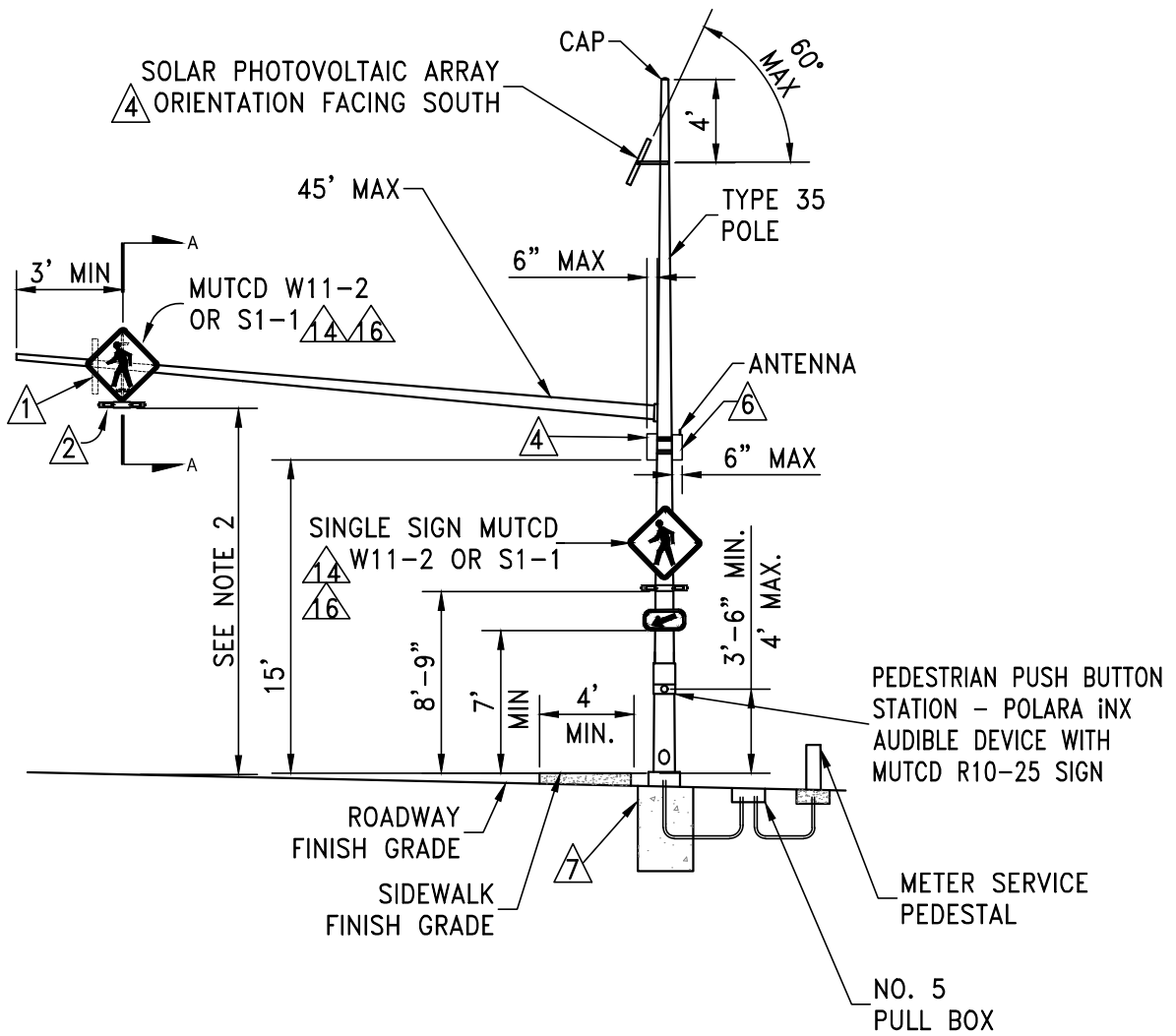

SECTION A-A

1/2"x4" CARRIAGE BOLT NUT W/
FIBER INSERT AND 2 FLAT
WASHERS THRU SIGN AND
POST (TYP.)

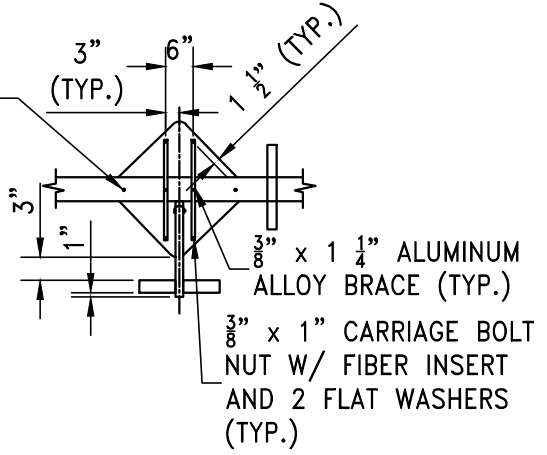

BACK VIEW OF SIGN

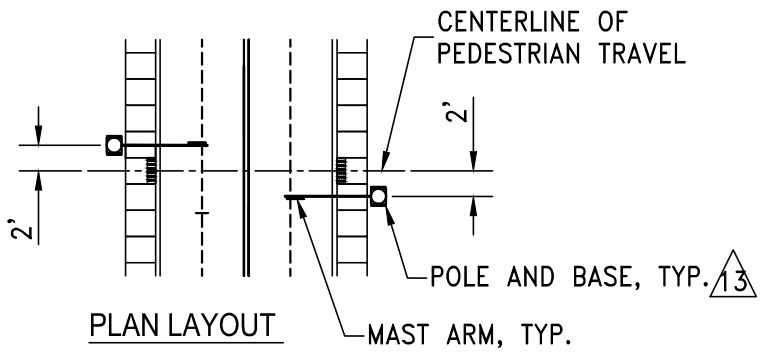

PLAN LAYOUT



STANDARD DETAILS FOR PUBLIC WORKS CONSTRUCTION

DRAWING No.

OVERHEAD RECTANGULAR RAPID
FLASHING BEACON (RRFB)

R-417G

APPROVED BY: KK DATE: 2/2026

NOTES:

1. MAST ARM DAMPER. INSTALL DAMPER ON BACKSIDE OF MAST ARM, WITHIN 24" OF THE END FARTHEST AWAY FROM THE POLE, TO REDUCE CYCLIC VIBRATION DUE TO WIND.
2. RECTANGULAR RAPID FLASHING BEACON (RRFB). LOCATE RRFB VERTICALLY ON MAST ARM NO LOWER THAN 18'-6" FROM ROADWAY SURFACE. DISTANCE IS MEASURED FROM THE BOTTOM EDGE OF THE RRFB TO THE ACTUAL TRAVEL LANE SURFACE. LOCATE RRFB AND SIGN HORIZONTALLY ON MAST ARM CENTERED OVER THE TRAVEL LANES.
3. RRFB MUST INCLUDE A PEDESTRIAN INDICATION SIDE FLASHER THAT FACES CROSSWALK.
4. SOLAR PHOTOVOLTAIC CONTROLLER, WITH BATTERY IF APPLICABLE.
5. SOLAR PHOTOVOLTAIC ARRAY SHALL PROVIDE A MINIMUM POWER GENERATION OF 90 WATTS. BATTERY STORAGE SHALL PROVIDE A MINIMUM OF 105 AMP-HOURS AT 12 VOLTS.
6. RECTANGULAR RAPID FLASHING BEACON SYSTEM (CARMANAH SC315-6 OR AN APPROVED EQUIVALENT). AC OR SOLAR.
7. POLE BASE AND FOOTING SHALL BE NDOT TYPE PILE FOOTING FOR TYPE 35 OR 35A POLE OR AS SPECIFIED BY A STRUCTURAL ENGINEER.
8. ALL NEW PEDESTRIAN PUSH BUTTONS FOR TRAFFIC SIGNALS SHALL BE 2" DIAMETER. UTILIZE POLARA INX AUDIBLE MID-BLOCK CROSSING PUSH BUTTON STATION SYSTEM OR APPROVED EQUAL. THE COLOR OF THE STATION SHOULD BE YELLOW. PEDESTRIAN PUSH BUTTONS LOCATED IN THE CENTER MEDIAN ISLANDS SHALL HAVE A BI-DIRECTIONAL ARROW. NEW PUSH BUTTON STATIONS SHALL HAVE MUTCD R10-25 SIGNS. THE TACTILE ARROW SHALL POINT IN THE DIRECTION OF THE CROSSING AND THE SIGN SHALL BE ALIGNED WITH THE CROSSWALK.
9. SIGN MATERIALS, CONSTRUCTION AND PLACEMENT SHALL BE IN CONFORMANCE WITH THE LATEST EDITION OF THE MANUAL ON UNIFORM TRAFFIC CONTROL DEVICES.
10. ALL EQUIPMENT SHALL BE WITHIN THE CITY OF RENO RIGHT-OF-WAY OR EASEMENT WITH POLE LOCATED BEHIND SIDEWALK.
11. SEE R-417E FOR ONE-LANE EACH DIRECTION ROADWAYS.
12. ALL EQUIPMENT SHALL BE SUBMITTED FOR TO THE CITY'S TRAFFIC ENGINEER FOR REVIEW AND APPROVAL PRIOR TO CONSTRUCTION. AFTER INSTALLATION, FLASHER SHALL BE FIELD TESTED IN THE PRESENCE OF THE TRAFFIC ENGINEER (OR DESIGNEE) AND PROVEN OPERATIONAL TO THE SATISFACTION OF THE CITY BEFORE FINAL CITY ACCEPTANCE.
13. ALIGN POLE BASE COVER SUCH THAT IT IS PARALLEL TO BACK OF SIDEWALK AND ALIGNS WITH NEAR EDGE OF THE DETECTABLE WARNING JOINT.
14. WHEN SCHEDULE INDICATES DUAL MOUNT, DOUBLE QUANTITY OF ALL FLASHERS AND TRAFFIC SIGNAL SIGNS, THEN MOUNT TO OPPOSITE SIDE OF POLE AND MAST ARM.
15. ALL SIGNS SHALL BE 3M DIAMOND GRADE (DG3), SERIES 4000, SHEETING WITH A CLEAR, TRANSPARENT OVERLAY 3M #1160i (LATEST EDITION) OR APPROVED EQUAL. SHALL BE A MATCHED COMPONENT SYSTEM.
16. FLUORESCENT YELLOW-GREEN BACKGROUND SHALL ONLY BE USED FOR SCHOOL ZONES, SCHOOL CROSSINGS, OR PEDESTRIAN SAFETY ZONES.



STANDARD DETAILS FOR PUBLIC WORKS CONSTRUCTION

DRAWING No.

NOTES - OVERHEAD RECTANGULAR RAPID
FLASHING BEACON (RRFB)

R-417H

APPROVED BY: KK | DATE: 2/2026

17. RRFB SHALL INCLUDE ALL EQUIPMENT AND MATERIALS NECESSARY TO PROVIDE A FULLY FUNCTIONAL SYSTEM PER MANUFACTURER'S RECOMMENDATIONS.
18. RRFB FLASH PATTERN SHALL BE COMPLIANT WITH MUTCD, LATEST EDITION, SECTION 4L.03.
19. LOCATION OF PEDESTRIAN PUSH BUTTONS SHALL BE ADA ACCESSIBLE AND MOUNTED NO MORE THAN 10" FROM A FLAT, ACCESSIBLE LANDING SPACE ($\leq 2\%$). SEE MUTCD, LATEST EDITION.
20. AUDIBLE INFORMATION DEVICES (AID) SHALL PROVIDE A LOCATOR TONE, SHALL NOT USE VIBROTACTILE INDICATIONS OR PERUSSIVE INDICATIONS. THE MESSAGE "WARNING LIGHTS ARE FLASHING" SHALL BE SPOKEN TWICE.



STANDARD DETAILS FOR PUBLIC WORKS CONSTRUCTION

NOTES - OVERHEAD RECTANGULAR RAPID
FLASHING BEACON (RRFB)

DRAWING No.

R-4171

APPROVED BY: KK | DATE: 2/2026

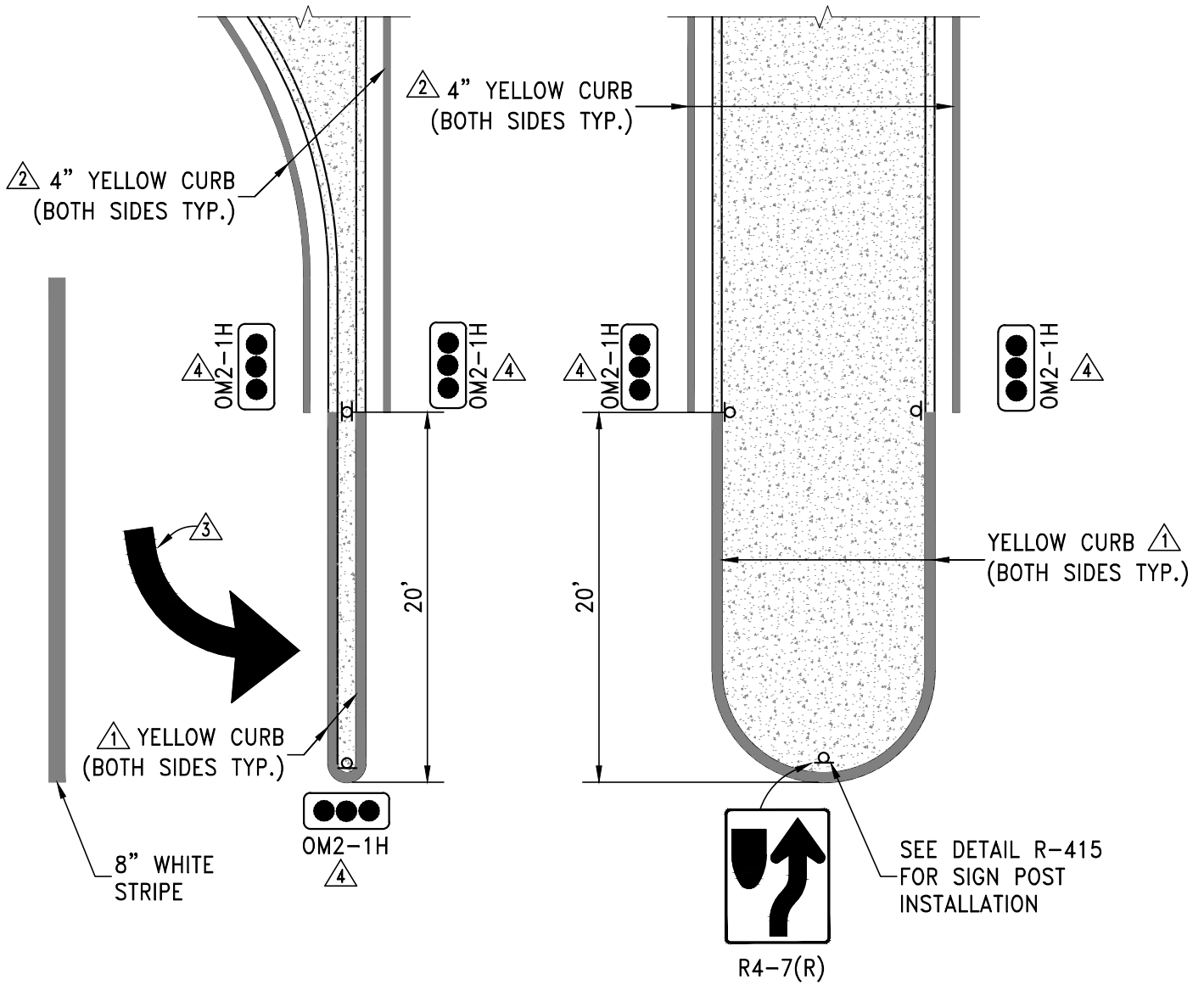

TYPICAL "TURN LANE"
MEDIAN ISLAND

TYPICAL "NO TURN LANE"
MEDIAN ISLAND

NOTES:

- 1. SHALL BE PAINTED WITH GLASS BEADS FULL HEIGHT AND TOP OF CURB.
 - 2. 4" YELLOW STRIPE SHALL BE 1' FROM FACE OF CURB.
 - 3. PAVEMENT MARKING ARROW(S) AND "ONLY" AS REQUIRED. REFER TO NEVADA DEPARTMENT OF TRANSPORTATION STANDARD PLANS FOR ROAD AND BRIDGE CONSTRUCTION DETAIL ST-6 FOR LAYOUT
 - 4. GUIDEPOST IN MEDIAN AREAS SHALL BE "SAFE HIT" OR APPROVED EQUAL, 8" CONCRETE ANCHOR WITH FLEXIBLE TYPE 2 GUIDEPOST.
5. ALL WORK SHALL CONFORM TO THE MANUAL ON UNIFORM TRAFFIC CONTROL DEVICES (M.U.T.C.D.), AND A POLICY ON GEOMETRIC DESIGN OF HIGHWAYS AND STREETS (GREEN BOOK).



STANDARD DETAILS FOR PUBLIC WORKS CONSTRUCTION

MEDIAN ISLAND
TRAFFIC CONTROL

DRAWING No.

R-418

APPROVED BY: KK | DATE: 2/2026

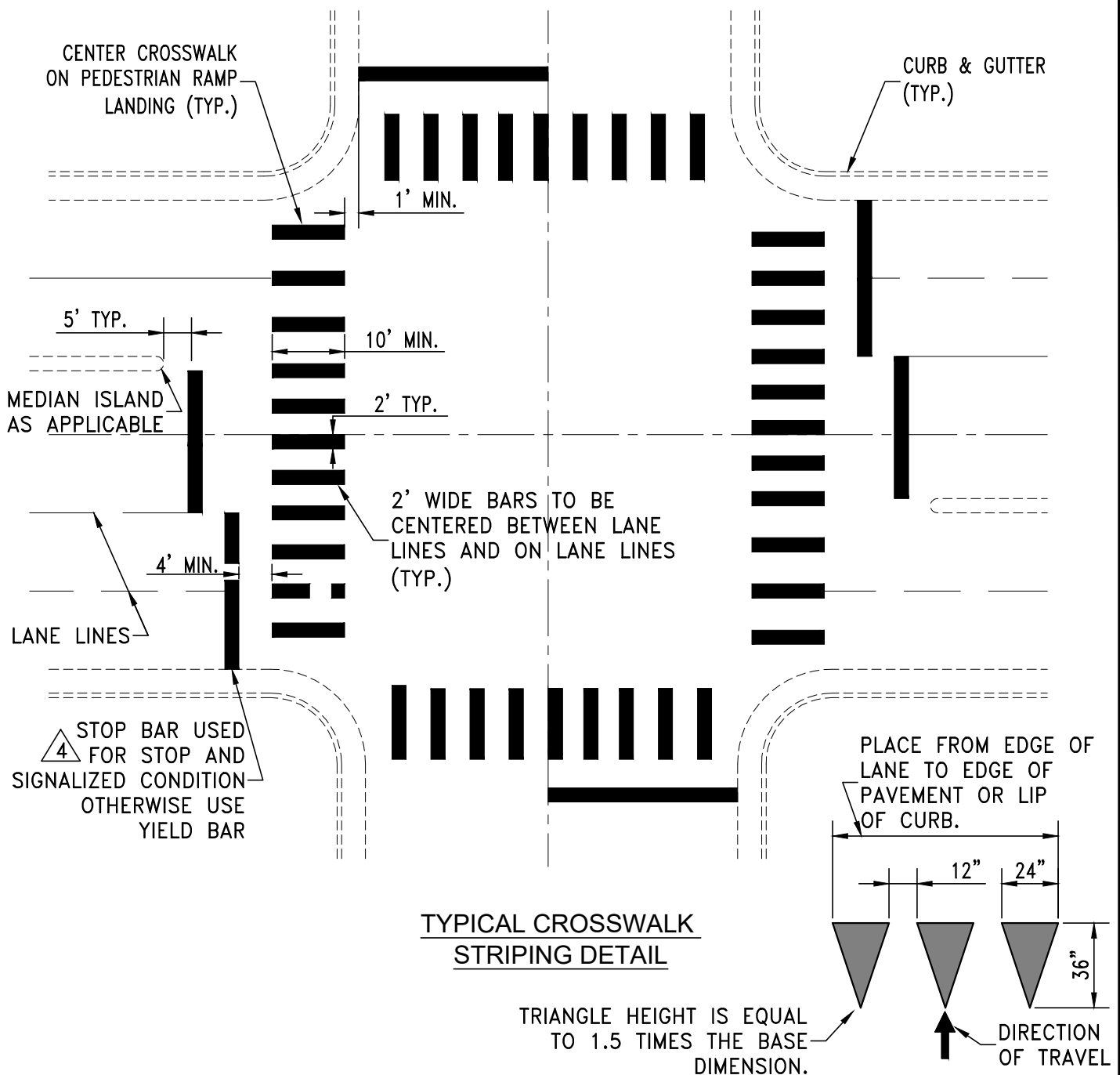

TYPICAL CROSSWALK STRIPING DETAIL

YIELD BAR MARKINGS

NOTES:

1. ALL STRIPING SHALL CONFORM TO THE MANUAL ON UNIFORM TRAFFIC CONTROL DEVICES (MUTCD) FOR STREETS AND HIGHWAYS, LATEST EDITION.
 2. PREFORMED THERMOPLASTIC PAVEMENT MARKINGS SHALL BE INSTALLED PER MANUFACTURERS RECOMMENDATIONS AND IN ACCORDANCE WITH SECTION 634 OF THE LATEST EDITION OF "STANDARD SPECIFICATIONS FOR ROAD AND BRIDGE CONSTRUCTION" PUBLISHED BY THE NEVADA DEPARTMENT OF TRANSPORTATION (NDOT), EXCEPT ALL THERMOPLASTIC MARKINGS WILL BE BETWEEN 0.090 AND 0.125 INCHES THICK. HOT-APPLIED EXTRUDED THERMOPLASTIC SHALL NOT BE USED.
 3. CROSSWALK MARKINGS SHALL BE INSTALLED AT ALL TRAFFIC SIGNAL LOCATIONS AND AT OTHER LOCATIONS AS DIRECTED BY ENGINEER.
4. PLACE 24" WIDE STOP BAR FOR SIGNALIZED CONTROL INTERSECTIONS. USE 12" WIDE STOP BAR FOR STOP CONTROL INTERSECTIONS. FOR YIELD CONDITION SEE YIELD MARKINGS ABOVE.



STANDARD DETAILS FOR PUBLIC WORKS CONSTRUCTION

CROSSWALK LEGEND

DRAWING No.

R-420

APPROVED BY: KK | DATE: 2/2026

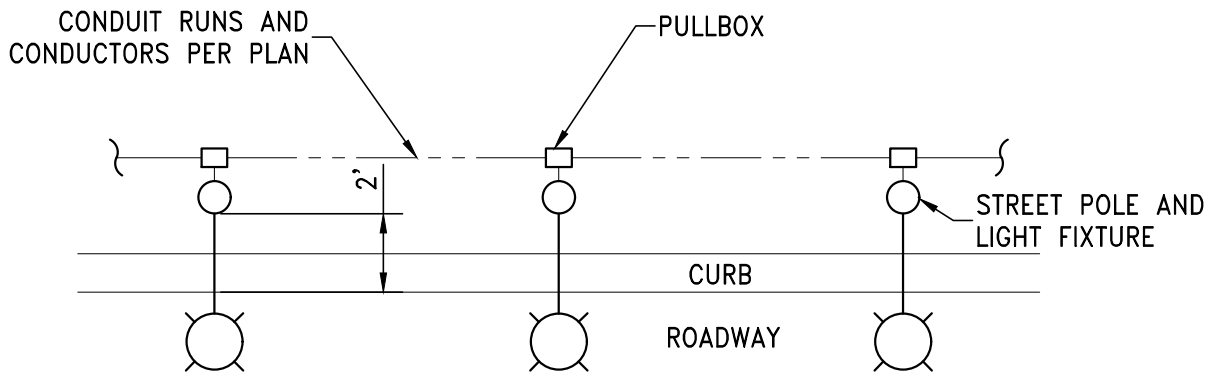

NOTES:

1. EACH LUMINAIRE SHALL HAVE A PULL BOX. SEE PLANS.
2. DESIGN SHALL MEET A MINIMUM ILLUMINANCE STANDARDS.



STANDARD DETAILS FOR PUBLIC WORKS CONSTRUCTION

TYPICAL STREET LIGHT LAYOUT

DRAWING No.

R-430

APPROVED BY: KK

DATE: 2/2026

CITY OF RENO URBAN TREES - NOTES

GENERAL NOTES

1. See Details R-500D through R-500J for tree list. The tree list is periodically updated by the City of Reno Urban Forester.
2. Urban Tree list is not intended to be exhaustive but identifies urban tolerant trees, suitable for USDA hardiness zones 6 and 7, and planted within the City of Reno.
3. Trees not found on the list may be planted within the City of Reno pending approval from the City of Reno Urban Forestry Department.
4. Trees may be planted as bare-root, balled & burlapped (B&B), grow bag or container grown.
5. Parkway and sidewalk tree wells should have a single central stem and be in tree form.
6. No one tree genus should make up more than 20% of an installation, unless approved by City of Reno Urban Forester.
7. Not all trees are appropriate for planting in all locations. For questions about appropriate planting sites or utilizing tree species not listed, please contact City of Reno Urban Forestry. The City of Reno reserves the right to prohibit tree species deemed unsuitable for planting on City Right of Way. Refer to Reno Municipal Code Title 18 for tree preservation requirements.

PLANTING SITE

8. Planting site areas for trees may be within Medians, Parkways, sidewalk tree wells or on Private Property. The tree list identifies each tree as excellent, good or not appropriate for the planting site.

City Parkway: The city parkway refers to a predominantly continuous soil planting area within the public right-of-way, typically greater than 5' wide and adjacent to the curb line of a street. Tree plantings in parkway widths less than 5' requires approval and coordination with City of Reno Urban Forester.

Small Parkway: Small parkways are defined as 5' and less in width. Trees indicated on the tree list as good and excellent in the small parkway column are better suited for narrow and other restricted size planting sites. It should be noted that even excellent choice trees may need to consider other factors including sight obstructions, sidewalk walking obstructions, and root conflicts in small parkways. Small parkways can also be particularly challenging environments for any tree and new parkways should be as wide as possible.

Median: Median trees are in landscape medians, boulevards, traffic circles, or other planters in the center of the roadway.

Private Property: Private property includes residential, corporate, parks, golf courses, cemeteries, or any other landscaped planting site not within the public right-of-way.



STANDARD DETAILS FOR PUBLIC WORKS CONSTRUCTION

DRAWING No.

NOTES
URBAN TREES

R-500A

APPROVED BY: MB | DATE: 12/2019

CITY OF RENO URBAN TREES - NOTES CONT.

Sidewalk Tree Well: An irrigated volume of non-compacted growing soil that meets all of the City of Reno Soil Specification provided for tree growth that is completely surrounded by pavement with roots restricted by a root barrier. This may be a traditional tree well, an open parkway, large planter, suspended pavement soil cell system, a combination of systems, or other means as defined by a project's Landscape Architect and approved by City of Reno Urban Forester. Structural soil may be considered for approval by Urban Forester at a value of 50% of non-compacted soil (Example: 100 cubic feet of structural soil = 50 cubic feet of usable soil volume). Minimum required soil volume is based on canopy size class (see Section 9), with volumes for each class listed below.

Canopy Size Class 1: Canopy size class 1 trees require a minimum usable soil volume of 75 cubic feet, Example: 5'x5'x3' deep

Canopy Size Class 2: Canopy size class 2 trees require a minimum usable soil volume of 150 cubic feet of soil, Example: 5'x10'x3' deep

Canopy Size Class 3: Canopy size class 3 trees require a minimum usable soil volume of 360 cubic feet of soil, Example: 10'x12'x3' deep

Canopy Size Class 4: Canopy size class 4 trees require a minimum usable soil volume of 600 cubic feet of soil, Example: 10'x20'x3' deep

OTHER CRITERIA FOR TREE SELECTION

9. In addition to planting site, below are additional criteria to be used to when selecting an urban tree from the list.

Under Wires: Smaller trees are better suited for planting under utility wires.

Salt Tolerant: Salt tolerant trees are recommended for use in areas which are subject to road salt.

Boron Tolerant: The southeast area of Reno is known to have toxic levels of boron in the soil. If a soil test indicates boron is higher than 0.5 parts per million, consider using boron tolerant trees.

Spring Planting Best: Trees which may require spring planting or at least to be nursery dug in the spring to improve establishment and survivability rates.

Promotes Diversity: Tree list indicates Species / Variety / Cultivar selections that occur infrequently in Reno. These selected streets would promote species diversity.

Canopy Size Class: How wide/tall a tree is expected to grow:

Class 1= <10', Class 2= 10'-30', Class 3= 30'-40', Class 4= >40'

Trees without canopy that qualify towards minimum requirements are listed as 'x' on the tree list.



STANDARD DETAILS FOR PUBLIC WORKS CONSTRUCTION

DRAWING No.

NOTES
URBAN TREES

R-500B

APPROVED BY: MB | DATE: 12/2019

CITY OF RENO URBAN TREES - NOTES CONT.

10. Availability abbreviation key for tree list

- GD = Good: Commonly available in most nurseries
- AV = Average: Available in many nurseries
- LTD = Limited: Available in some nurseries in limited quantities or sizes
- VLTD = Very Limited: Somewhat difficult to find in nurseries
- NA = Not Available: Currently no known growers

11. Hardiness abbreviation key for tree list

- EX = Excellent: Good overall survivability
- GD = Good: Performs well
- AV = Average: Grows within the area
- AV-PR = Average to Poor: May grow within protected sites but otherwise not survivable in exposed sites

12. Ease of Transplant abbreviation key for tree list

- GD = Good: Easily transplantable
- AV = Average: Transplants reasonably well
- DIF= Difficult: Requires special consideration for successful transplant

13. Drought Tolerance abbreviation key for tree list

- GD = Good: Needs irrigation but once established can survive on infrequent or low volume waterings
- AV = Average: Needs semi-regular deep irrigation. Drip or overhead irrigation that wets soil to 10" depth once a week is generally sufficient. Overhead / spray irrigation not allowed in City Right-if-Way.
- IN = Intolerant: Needs a well irrigated landscape with proper drainage that receives regular water that wets soil consistently to 10" depth. Overhead irrigation in turf or wood mulch strongly recommended. Drip irrigation not recommended.

14. Highly Recommended for Reno

Trees noted to do especially well in Reno's challenging tree environment with low maintenance costs and few problems are noted here with a YES. Other comments or concerns which may appear in this column are listed below.

- IPR = Insect problems: Known to have issues with insect infestations
- OU = Overused: Occurs frequently within Reno
- SDL = Seedless: Does not seasonally discharge seeds / seed pods
- UP = Unproven: No history of use / insufficient history of use by City of Reno



STANDARD DETAILS FOR PUBLIC WORKS CONSTRUCTION

DRAWING No.

NOTES URBAN TREES

R-500C

APPROVED BY: MB | DATE: 12/2019

CITY OF RENO URBAN TREES - NOTES CONT.

PROHIBITED SPECIES

The following species shall not be planted in City Right of Way/ parkways. Although the City of Reno discourages these trees from being planted on private property, the City does not prohibit doing so nor does the City require the removal of live trees growing on private property. Tree preservation requirements from Municipal Code 18.12 apply.

Common Name	Genus	Species	Reason tree prohibited from planting
Box Elder	<i>Acer</i>	<i>negundo</i>	Box elder bugs, verticillium wilt, nuisance seeds
Silver Maple	<i>Acer</i>	<i>saccharinum</i>	Weak/ brittle wood, invasive roots
Russian Olive**	<i>Eleangus</i>	<i>angustifolia</i>	Thorns, invasive species
Walnut	<i>Juglans</i>	<i>spp.</i>	Large fruit can fall and cause damage
Goldenchain Tree	<i>Laburnum</i>	<i>anagyroides</i>	Poisonous
Cottonwood	<i>Populus</i>	<i>tremuloides</i>	Weak/ brittle wood, invasive roots. Seedless cultivars acceptable with forester approval*
'Purple Robe' Black Locust	<i>Robinia</i>	<i>pseudoacacia</i> 'Purple Robe'	Poor structure, high limb failure rate, locust borer
Willow	<i>Salix</i>	<i>spp.</i>	Weak/ brittle wood, invasive roots, short life span
Tamarisk	<i>Tamarix</i>	<i>spp.</i>	Invasive/ noxious weed
Siberian Elm	<i>Ulmus</i>	<i>pumila</i>	Elm leaf beetle, limb failure, invasive roots
Ash species	<i>Fraxinus</i>	<i>spp.</i>	Ash borers, aphids. Certain cultivars may be considered after review from Urban Forester.
Chanticleer pear**	<i>Pyrus</i>	<i>calleryana</i>	This species makes up more than 10% of our public tree inventory. Planting of pears will be prohibited on City property until they represent less than 10% of the public tree inventory.

** Denotes Species may be invasive and should not be planted in or adjacent to naturalized areas.



STANDARD DETAILS FOR PUBLIC WORKS CONSTRUCTION

DRAWING No.

**NOTES - URBAN TREES
PROHIBITED SPECIES LIST**

R-500D

APPROVED BY: MB | DATE: 12/2019



URBAN TREE LIST

STANDARD DETAILS FOR PUBLIC WORKS CONSTRUCTION

DRAWING No.

APPROVED BY: MB DATE: 12/2019

R-500E

City of Reno Urban Tree Planting List			Planting Site										Other								
■ Denotes excellent tree candidate ▒ Denotes good tree candidate □ Blank Box Denotes tree not appropriate for site			City Parkway	Small Parkway	Sidewalk Tree Well	Median	Private Property	Under Wires	Boron Tolerant	Salt Tolerant	Spring Planting Best	Promotes Diversity	Low Maintenance	Disease/Pest Resistant	Availability	Hardness	Ease of Transplant	Drought Tolerance	USDA Hardiness Zone	Canopy Size Class	Highly Recommended for Reno
Common Name	Genus	Species																			
White Fir	<i>Abies</i>	<i>concolor</i>												AV	GD	GD	IN	3-7	x		
Trident Maple	<i>Acer</i>	<i>buergerianum</i>	▒	▒										LTD	AV	AV	AV	5-10	2		
Hedge Maple	<i>Acer</i>	<i>campestre</i>		▒										AV	GD	GD	AV	4-8	1		
Amur Maple	<i>Acer</i>	<i>ginnala 'Flame'</i>		▒										AV	AV	AV	AV	3-8	1		
Miyabe Maple	<i>Acer</i>	<i>miyabei</i>												GD	GD	GD	AV	5-8	4	YES	
Black Maple	<i>Acer</i>	<i>nigrum</i>												LTD	AV	AV	AV	4-8	3		
Crimson King Maple	<i>Acer</i>	<i>platanooides 'Crimson King'</i>												GD	GD	GD	AV	3-7	4		
Norway Maple	<i>Acer</i>	<i>platanooides 'Deborah'</i>												GD	GD	GD	AV	3-7	4		
Sycamore Maple	<i>Acer</i>	<i>pseudoplatanus</i>												NA	AV	AV	AV	5-8	4		
Big Tooth Maple	<i>Acer</i>	<i>grandidentatum</i>												NA	AV	AV	AV	4-7	2		
Sugar Maple	<i>Acer</i>	<i>saccharum</i>	▒											AV	AV	AV	AV	4-8	4		
Pacific Sunset Maple	<i>Acer</i>	<i>truncatum x platanooides</i>	▒	▒										AV	GD	GD	AV	4-8	3		
Autumn Blaze Maple	<i>Acer</i>	<i>x freemanii 'Autumn Blaze'</i>	▒											GD	GD	GD	AV	3-9	4		
Marmo Maple	<i>Acer</i>	<i>x freemanii 'Marmo'</i>	▒											GD	GD	GD	AV	4-7	4		
Ohio Buckeye	<i>Aesculus</i>	<i>glabra</i>	▒											AV	GD	AV	AV	4-7	4		
Baumann Horsechestnut	<i>Aesculus</i>	<i>hippocastanum 'Baumanii'</i>												LTD	GD	AV	AV	4-8	4		
Autumn Splendor Buckeye	<i>Aesculus</i>	<i>x arnoldiana</i>												AV	GD	AV	AV	4-8	3		
Yellow Buckeye	<i>Aesculus</i>	<i>octandra</i>												LTD	GD	AV	AV	4-8	4		
Red Buckeye	<i>Aesculus</i>	<i>pavia</i>	▒											VLTD	GD	AV	AV	4-8	2		
European Black Alder	<i>Alnus</i>	<i>glutinosa</i>	▒											GD	GD	GD	IN	4-7	3		
White Alder	<i>Alnus</i>	<i>incana</i>												LTD	GD	GD	IN	2-6	3		
Apple Serviceberry	<i>Amelanchier</i>	<i>x grandiflora</i>	▒	▒										LTD	GD	GD	IN	3-7	1		
Allegheny Serviceberry	<i>Amelanchier</i>	<i>laevis</i>	▒											LTD	GD	GD	IN	4-9	1		
River Birch	<i>Betula</i>	<i>nigra</i>	▒											GD	GD	AV	AV	4-9	2		
Heritage River Birch	<i>Betula</i>	<i>nigra 'Heritage'</i>	▒											GD	GD	AV	AV	4-9	2		
California Incense Cedar	<i>Calocedrus</i>	<i>decurrens</i>												GD	GD	GD	GD	5-8	x	YES	
European Hornbeam	<i>Carpinus</i>	<i>betulus</i>	▒	▒										AV	GD	DIF	AV	4-8	2		
American Hornbeam	<i>Carpinus</i>	<i>caroliniana</i>	▒											AV	GD	DIF	AV	3-9	2		



URBAN TREE LIST

STANDARD DETAILS FOR PUBLIC WORKS CONSTRUCTION

City of Reno Urban Tree Planting List

- Denotes excellent tree candidate
- Denotes good tree candidate
- Blank Box Denotes tree not appropriate for site

City of Reno Urban Tree Planting List			Planting Site										Other											
			City Parkway	Small Parkway	Sidewalk Tree Well	Median	Private Property	Under Wires	Boron Tolerant	Salt Tolerant	Spring Planting Best	Promotes Diversity	Low Maintenance	Disease/Pest Resistant	Availability	Hardiness	Ease of Transplant	Drought Tolerance	USDA Hardiness Zone	Canopy Size Class	Highly Recommended for Reno			
Common Name	Genus	Species	Scientific Name																					
Bitternut Hickory	<i>Carya</i>	<i>cordiformis</i>																NA	AV-PR	DIF	AV	4-9	4	
Pignut Hickory	<i>Carya</i>	<i>glabra</i>																NA	AV-PR	DIF	AV	5-8	4	
Shellbark Hickory	<i>Carya</i>	<i>laciniosa</i>																NA	AV-PR	DIF	AV	5-8	4	
Shagbark Hickory	<i>Carya</i>	<i>ovata</i>																LTD	AV	DIF	AV	4-8	4	
Mockernut Hickory	<i>Carya</i>	<i>tomentosa</i>																NA	AV-PR	DIF	AV	5-9	4	
Chinese Catalpa	<i>Catalpa</i>	<i>ovata</i>																VLTD	AV	GD	AV	5-8	4	
Southern Catalpa	<i>Catalpa</i>	<i>bignonioides</i>																GD	GD	GD	AV	4-8	3	
Purple Catalpa	<i>Catalpa</i>	<i>x. erubescens 'Purpurea'</i>																GD	GD	GD	AV	4-8	4	YES
Northern Catalpa	<i>Catalpa</i>	<i>speciosa</i>																GD	EX	GD	AV	4-8	4	YES
Atlas Cedar	<i>Cedrus</i>	<i>atlantica</i>																GD	GD	GD	GD	6-8	x	YES
Deodar Cedar	<i>Cedrus</i>	<i>deodara</i>																GD	GD	GD	GD	7-9	x	
Sugarberry	<i>Celtis</i>	<i>laevigata</i>																AV	AV	GD	AV	5-9	4	
Chinese Hackberry	<i>Celtis</i>	<i>sinesis</i>																LTD	GD	DIF	AV	7-9	4	
Hackberry	<i>Celtis</i>	<i>occidentalis</i>																GD	GD	GD	AV	3-9	4	YES
Katsura Tree	<i>Cercidiphyllum</i>	<i>japonicum</i>																GD	GD	DIF	AV	4-8	2	
Eastern Redbud	<i>Cercis</i>	<i>canadensis</i>																GD	AV	AV	AV	3-9	1	
White Fringetree	<i>Chionanthus</i>	<i>virginicus</i>																VLTD	AV	DIF	AV	4-9	1	
American Yellowwood	<i>Cladrastis</i>	<i>kentuckea</i>																VLTD	AV	AV	AV	4-8	3	
Pagoda Dogwood	<i>Cornus</i>	<i>alternifolia</i>																AV	AV-PR	AV	AV	4-8	3	
Corneliancherry Dogwood	<i>Cornus</i>	<i>mas</i>																GD	GD	GD	AV	4-8	1	
Turkish Hazelnut	<i>Corylus</i>	<i>colurna</i>																AV	AV	AV	AV	4-7	3	
Thornless Cockspur Hawthorn	<i>Crataegus</i>	<i>crusgalli</i>																GD	GD	GD	AV	4-7	2	
Washington Hawthorn	<i>Crataegus</i>	<i>phaenopyrum</i>																GD	GD	GD	AV	4-8	2	
Winter King Green Hawthorn	<i>Crataegus</i>	<i>viridis 'Winter King'</i>																GD	GD	GD	AV	4-7	2	
Arizona Cypress	<i>Cupressus</i>	<i>arizonica</i>																GD	GD	GD	GD	7-9	x	
Italian Cypress	<i>Cupressus</i>	<i>sempervirens</i>																VLTD	AV	AV	GD	7-10	x	UP
Leyland Cypress	<i>X Cupressocyparis</i>	<i>leylandii</i>																GD	GD	GD	GD	6-10	x	
Hardy Rubber Tree	<i>Eucommia</i>	<i>ulmoides</i>																VLTD	AV	GD	AV	5-7	3	

DRAWING No.

R-500F

APPROVED BY: MB DATE: 12/2019



URBAN TREE LIST

STANDARD DETAILS FOR PUBLIC WORKS CONSTRUCTION

R-500G

DRAWING No.

City of Reno Urban Tree Planting List

- Denotes excellent tree candidate
- Denotes good tree candidate
- Blank Box Denotes tree not appropriate for site

City of Reno Urban Tree Planting List			Planting Site							Other											
Common Name	Scientific Name		City Parkway	Small Parkway	Sidewalk Tree Well	Median	Private Property	Under Wires	Boron Tolerant	Salt Tolerant	Spring Planting Best	Promotes Diversity	Low Maintenance	Disease/Pest Resistant	Availability	Hardiness	Ease of Transplant	Drought Tolerance	USDA Hardiness Zone	Canopy Size Class	Highly Recommended for Reno
	Genus	Species																			
American Beech	<i>Fagus</i>	<i>grandifolia</i>												LTD	AV-PR	DIF	AV	4-9	4		
European Beech	<i>Fagus</i>	<i>sylvatica</i>												AV	AV-PR	DIF	AV	5-9	4		
Ginkgo, Male Only	<i>Ginkgo</i>	<i>biloba</i>												AV	GD	GD	AV	4-9	4	YES	
Magyar Ginkgo	<i>Ginkgo</i>	<i>biloba 'Magyar'</i>												LTD	GD	GD	AV	4-9	4		
Princeton Sentry Ginkgo	<i>Ginkgo</i>	<i>biloba 'Princeton Sentry'</i>												LTD	GD	GD	AV	4-9	4		
Thornless Honeylocust	<i>Gleditsia</i>	<i>triacanthos var. inermis</i>												GD	GD	GD	AV	4-8	4		
Kentucky Coffeetree	<i>Gymnocladus</i>	<i>dioicus</i>												GD	EX	GD	AV	4-8	4	YES	
Seedless Kentucky Coffeetree	<i>Gymnocladus</i>	<i>dioicus 'Espresso'</i>												GD	EX	GD	AV	4-8	4	YES	
Eastern Redcedar	<i>Juniperus</i>	<i>virginiana</i>												AV	GD	GD	AV	3-9	x		
Canaert Eastern Redcedar	<i>Juniperus</i>	<i>virginiana 'Canaertii'</i>												AV	GD	GD	AV	3-9	1		
European Larch	<i>Larix</i>	<i>decidua</i>												AV	AV	AV	AV	3-6	x		
Sweetgum	<i>Liquidambar</i>	<i>styraciflua</i>												LTD	AV-PR	DIF	AV	5-9	4	YES	
Tuliptree	<i>Liriodendron</i>	<i>tulipifera</i>												LTD	AV-PR	DIF	AV	5-9	4	YES	
Thornless Osage Orange	<i>Maclura</i>	<i>pomifera 'Wichita'</i>												VLTD	GD	GD	AV	4-10	3		
Cucumbertree Magnolia	<i>Magnolia</i>	<i>acuminata</i>												LTD	AV	AV	AV	4-8	3		
Crabapple	<i>Malus</i>	<i>species</i>												GD	GD	GD	AV	3-9	1		
Dawn Redwood	<i>Metasequoia</i>	<i>glyptostroboides</i>												VLTD	AV	AV	AV	5-9	4		
White Mulberry	<i>Morus</i>	<i>alba</i>												GD	GD	GD	AV	5-9	2	SDL	
Red Mulberry	<i>Morus</i>	<i>rubra</i>												VLTD	GD	GD	AV	5-9	3		
Black Gum, Tulepo	<i>Nyssa</i>	<i>sylvatica</i>												LTD	AV-PR	AV	AV	4-9	2		
Ironwood	<i>Ostrya</i>	<i>virginiana</i>												AV	GD	GD	AV	3-9	2	YES	
Black Hills Spruce	<i>Picea</i>	<i>glauca</i>												GD	AV	GD	AV	2-7	x		
Serbian Spruce	<i>Picea</i>	<i>omorika</i>												GD	AV	GD	AV	4-7	x		
Oriental Spruce	<i>Picea</i>	<i>orientalis</i>												GD	AV-PR	GD	AV	4-7	x		
Colorado Blue Spruce	<i>Picea</i>	<i>pungens</i>												GD	AV	GD	AV	2-8	x		
Rocky Mountain Bristlecone Pine	<i>Pinus</i>	<i>aristota</i>												LTD	GD	AV	GD	4-7	x		
Lancebark Pine	<i>Pinus</i>	<i>bungeana</i>												LTD	AV	AV	AV	4-7	x		
Limber Pine	<i>Pinus</i>	<i>flexilis 'Vanderwolf'</i>												GD	GD	AV	AV	5-8	x		

APPROVED BY: MB DATE: 12/2019



URBAN TREE LIST

STANDARD DETAILS FOR PUBLIC WORKS CONSTRUCTION

APPROVED BY: MB DATE: 12/2019

R-500H

DRAWING No.

City of Reno Urban Tree Planting List			Planting Site								Other											
<input checked="" type="checkbox"/> Denotes excellent tree candidate <input checked="" type="checkbox"/> Denotes good tree candidate <input type="checkbox"/> Blank Box Denotes tree not appropriate for site			City Parkway	Small Parkway	Sidewalk Tree Well	Median	Private Property	Under Wires	Boron Tolerant	Salt Tolerant	Spring Planting Best	Promotes Diversity	Low Maintenance	Disease/Pest Resistant	Availability	Hardness	Ease of Transplant	Drought Tolerance	USDA Hardiness Zone	Canopy Size Class	Highly Recommended for Reno	
Scientific Name		Genus																				Species
Common Name	Genus																					
Jeffrey Pine	<i>Pinus</i>	<i>jeffreyi</i>													LTD	GD	AV	GD	5-7	x		
Single Leaf Pinyon Pine	<i>Pinus</i>	<i>monophylla</i>													LTD	GD	AV	GD	6-8	x	YES	
Western White Pine	<i>Pinus</i>	<i>monticola</i>													VLTD	AV	AV	AV	4-9	x		
Austrian Pine	<i>Pinus</i>	<i>nigra</i>													GD	GD	GD	GD	4-7	x	OU	
Ponderosa Pine	<i>Pinus</i>	<i>ponderosa</i>													AV	GD	AV	AV	3-7	x		
Scotch Pine	<i>Pinus</i>	<i>sylvestris</i>													GD	GD	GD	AV	2-9	x		
Japanese Black Pine	<i>Pinus</i>	<i>thunbergii</i>													VLTD	AV	AV	AV	6-9	x		
Chinese Pistache	<i>Pistacia</i>	<i>chinensis</i>													AV	EX	GD	GD	6-9	3	YES	
American Sycamore	<i>Platanus</i>	<i>occidentalis</i>													AV	AV	GD	AV	5-9	4		
London Planetree	<i>Platanus</i>	<i>x acerifolia</i>													LTD	AV	GD	AV	5-8	4	YES	
Siouxland Poplar	<i>Populus</i>	<i>deltoides 'Siouxland'</i>													LTD	AV	GD	AV	3-9	4		
Freemont Cottonwood	<i>Populus</i>	<i>freemontii</i>													LTD	EX	GD	AV	3-9	4		
Quaking Aspen	<i>Populus</i>	<i>tremuloides</i>													AV	AV	GD	AV	1-8	3		
Purple-Leaf Plum	<i>Prunus</i>	<i>cerasifera</i>													GD	GD	GD	GD	4-8	1	OU	
Sargent Cherry	<i>Prunus</i>	<i>sargentii</i>													VLTD	AV	GD	AV	5-8	2		
Canada Red Coke Cherry	<i>Prunus</i>	<i>virginiana 'Canada Red'</i>													AV	AV	GD	AV	2-7	2		
Douglas Fir	<i>Pseudotsuga</i>	<i>menziesii</i>													GD	AV	GD	AV	4-7	x		
White Oak	<i>Quercus</i>	<i>alba</i>													LTD	GD	DIF	AV	3-9	4		
Fastigate Oak	<i>Quercus</i>	<i>alba x robur</i>													VLTD	GD	AV	AV	5-9	3		
Swamp White Oak	<i>Quercus</i>	<i>bicolor</i>													GD	GD	GD	AV	4-8	4		
Blue Oak	<i>Quercus</i>	<i>douglasii</i>													VLTD	EX	AV	EX	6-9	3	YES	
Hill's Oak	<i>Quercus</i>	<i>ellipsoidalis</i>													AV	AV	GD	AV	3-7	4	YES	
Gambel Oak	<i>Quercus</i>	<i>gambelii</i>													LTD	GD	GD	GD	2-7	2		
Oregon White Oak	<i>Quercus</i>	<i>garryana</i>													LTD	GD	GD	GD	6-9	4		
Shingle Oak	<i>Quercus</i>	<i>imbricaria</i>													AV	EX	AV	AV	5-8	4	YES	
California Black Oak	<i>Quercus</i>	<i>kelloggii</i>													VLTD	EX	AV	EX	7-9	4	YES	
Valley Oak	<i>Quercus</i>	<i>lobata</i>													AV	GD	GD	GD	6-11	4	YES	
Bur Oak	<i>Quercus</i>	<i>macrocarpa</i>													GD	AV	DIF	AV	3-8	4	YES	



URBAN TREE LIST

STANDARD DETAILS FOR PUBLIC WORKS CONSTRUCTION

R-5001

DRAWING No.

APPROVED BY: MB DATE: 12/2019

City of Reno Urban Tree Planting List			Planting Site								Other										
<input checked="" type="checkbox"/> Denotes excellent tree candidate <input checked="" type="checkbox"/> Denotes good tree candidate <input type="checkbox"/> Blank Box Denotes tree not appropriate for site			City Parkway	Small Parkway	Sidewalk Tree Well	Median	Private Property	Under Wires	Boron Tolerant	Salt Tolerant	Spring Planting Best	Promotes Diversity	Low Maintenance	Disease/Pest Resistant	Availability	Hardiness	Ease of Transplant	Drought Tolerance	USDA Hardiness Zone	Canopy Size Class	Highly Recommended for Reno
Common Name	Genus	Scientific Name																			
		Species																			
Chinkapin Oak	<i>Quercus</i>	<i>muehlenbergii</i>												AV	GD	AV	AV	4-8	4	YES	
Chestnut Oak	<i>Quercus</i>	<i>prinus</i>												AV	AV	AV	AV	4-8	4		
English Oak	<i>Quercus</i>	<i>robur</i>												VLTD	GD	AV	AV	3-8	4		
Shumard's Oak	<i>Quercus</i>	<i>shumardii</i>												LTD	GD	AV	AV	3-9	4		
Heritage Oak	<i>Quercus</i>	<i>x macdanielii 'Clemons'</i>												VLTD	GD	AV	AV	4-8	4		
Staghorn Sumac	<i>Rhus</i>	<i>typhina</i>												AV	GD	GD	AV	3-8	1		
Black Locust	<i>Robinia</i>	<i>pseudoacacia</i>												LTD	AV	AV	AV	4-9	3		
Giant Sequoia	<i>Sequoiadendron</i>	<i>giganteum</i>												GD	GD	GD	GD	6-8	x		
Weeping Giant Sequoia	<i>Sequoiadendron</i>	<i>giganteum 'Pendulum'</i>												AV	GD	AV	GD	6-8	x		
Japanese Pagodatree	<i>Styphnolobium</i>	<i>japonica</i>												VLTD	AV	GD	AV	5-9	3		
Mountain Ash	<i>Sorbus</i>	<i>aucuparia</i>												AV	AV	GD	AV	3-7	3		
China Snow® Peking Lilac	<i>Syringa</i>	<i>pekinesis 'Morton'</i>												GD	GD	GD	AV	4-7	1		
Summer Snow Japanese Tree Lilac	<i>Syringa</i>	<i>reticulata ssp. Reticulata 'Summer Snow'</i>												LTD	GD	GD	AV	3-7	1		
Ivory Silk Japanese Tree Lilac	<i>Syringa</i>	<i>reticulata ssp. reticulata 'Ivory Silk'</i>												GD	GD	GD	AV	3-8	1	YES	
Baldcypress	<i>Taxodium</i>	<i>distichum</i>												GD	GD	GD	AV	5-11	4		
Shawnee Brave Baldcypress	<i>Taxodium</i>	<i>distichum 'Shawnee Brave'</i>												GD	GD	GD	AV	5-11	4		
Western Red Cedar	<i>Thuja</i>	<i>plicata</i>												VLTD	AV	AV	AV	5-9	x		
Eastern Arborvitae	<i>Thuja</i>	<i>occidentalis</i>												GD	GD	GD	AV	3-7	x		
American Sentry Linden	<i>Tilia</i>	<i>americana 'American Sentry'</i>												GD	GD	GD	AV	3-8	4	YES	
Boulevard Linden	<i>Tilia</i>	<i>americana 'Boulevard'</i>												LTD	GD	GD	AV	3-8	4	YES	
Redmond Linden	<i>Tilia</i>	<i>americana 'Redmond'</i>												GD	GD	GD	AV	3-8	4	YES	
Legend™ Linden	<i>Tilia</i>	<i>americana 'Wandell'</i>												LTD	GD	GD	AV	3-8	4		
American Linden	<i>Tilia</i>	<i>americana</i>												AV	GD	GD	AV	3-9	4	YES	
White Basswood	<i>Tilia</i>	<i>americana var. heterophylla</i>												VLTD	GD	GD	AV	4-8	4		
Glenleven Littleleaf Linden	<i>Tilia</i>	<i>cordata 'Glenleven'</i>												GD	GD	GD	AV	2-7	3		
Golden Cascade Linden	<i>Tilia</i>	<i>cordata 'Golden Cascade'</i>												LTD	GD	GD	AV	3-7	3		
Littleleaf Linden	<i>Tilia</i>	<i>cordata</i>												GD	GD	GD	AV	3-7	3		
Norlin® Linden	<i>Tilia</i>	<i>cordata 'Norlin'</i>												LTD	GD	GD	AV	3-7	3		



URBAN TREE LIST

STANDARD DETAILS FOR PUBLIC WORKS CONSTRUCTION

City of Reno Urban Tree Planting List			Planting Site										Other										
<input checked="" type="checkbox"/> Denotes excellent tree candidate <input checked="" type="checkbox"/> Denotes good tree candidate <input type="checkbox"/> Blank Box Denotes tree not appropriate for site			City Parkway	Small Parkway	Sidewalk Tree Well	Median	Private Property	Under Wires	Boron Tolerant	Salt Tolerant	Spring Planting Best	Promotes Diversity	Low Maintenance	Disease/Pest Resistant	Availability	Hardiness	Ease of Transplant	Drought Tolerance	USDA Hardiness Zone	Canopy Size Class	Highly Recommended for Reno		
Scientific Name		Common Name																				Genus	Species
Harvest Gold® Linden	<i>Tilia</i>	<i>mongolica</i>																				'Harvest Gold'	
Silver Linden	<i>Tilia</i>	<i>tomentosa</i>													LTD	GD	GD	AV	5-8	4	YES		
Crimean Linden	<i>Tilia</i>	<i>x euchlora</i>													VLTD	GD	GD	AV	3-7	4			
Valley Forge Elm	<i>Ulmus</i>	<i>americana</i>	'Valley Forge'												AV	GD	GD	AV	3-9	4	IPR		
Princeton Elm	<i>Ulmus</i>	<i>americana</i>	'Princeton'												AV	GD	GD	AV	3-9	4	IPR		
Regal Elm	<i>Ulmus</i>	<i>carpinifolia</i>	'Regal'												AV	GD	GD	AV	4-7	4			
Commendation™ Elm	<i>Ulmus</i>	<i>carpinifolia</i>	'Morton Stalwart'												AV	GD	GD	AV	4-9	4			
Discovery Elm	<i>Ulmus</i>	<i>daurica</i>	<i>var. japonica</i>												LTD	GD	GD	AV	2-7	4	YES		
Accolade® Elm	<i>Ulmus</i>	<i>japonica</i>	<i>x wilsoniana</i>												AV	EX	GD	AV	5-8	4	YES		
Patriot Elm	<i>Ulmus</i>	<i>wilsoniana</i>													AV	GD	GD	AV	4-7	4			
Prospector Wilson's Elm	<i>Ulmus</i>	<i>wilsoniana</i>													AV	EX	GD	AV	4-7	4	YES		
Triumph™ Elm	<i>Ulmus</i>														GD	EX	GD	AV	4-9	4			
Emerald Sunshine Elm	<i>Ulmus</i>	<i>propinqua</i>													GD	EX	GD	AV	4-9	3	YES		
Chinese Lacebark Elm	<i>Ulmus</i>	<i>parvifolia</i>													GD	GD	GD	AV	5-9	3	YES		
Village Green Japanese Zelkova	<i>Zelkova</i>	<i>serrata</i>													LTD	GD	AV	AV	5-8	3			
Wireless' Zelkova	<i>Zelkova</i>	<i>serrata</i>													VLTD	GD	AV	AV	5-8	2			

APPROVED BY: MB DATE: 12/2019

R-500J

DRAWING No.

SOIL INSTALLATION

All construction debris including base material, limestone, demolition remnants, asphalt, or otherwise disturbed or modified soil/ material must be removed completely and replaced with soil that meets Table 1 specifications in R-500L. Native soil may be amended in a homogenous mixture to meet this specification or the existing soil may be removed and replaced with soil that meets soil composition specifications in Table 1. Existing native soil below excavation shall be scarified a minimum 2" depth to encourage percolation from and melding with amended topsoil.

During maintenance work such as replacement of sidewalk, street, carriage walks, driveways, curb and gutter, or other where existing vegetation is present that is to be preserved, only the soil that has been disturbed or was otherwise subjected to excavation must be replaced or meet this criteria.

Newly constructed landscape areas that are to be planted with sod, shrubs or other plant material with a mature height of less than 10 feet must include installation of soil meeting the Table 1 specifications throughout the installation to a depth of 6". In landscape areas that are to contain trees, soil must meet the specifications in Table 1 to a minimum depth of 24".

All soil installations (replacement and new construction) shall be mounded slightly and saturated with water immediately after installation to allow for settling and to minimize losses from wind. Soil uncovered with mulch or similar erosion control should be saturated again between 7 and 14 days following installation. Any areas that do settle should be filled with additional approved soil.



STANDARD DETAILS FOR PUBLIC WORKS CONSTRUCTION

**SOIL INSTALLATION
SPECIFICATIONS**

DRAWING No.

R-500K

APPROVED BY: MB | DATE: 12/2019

SOIL COMPOSITION

Soil shall consist of fertile, friable soil of loamy character that contains organic matter in quantities natural to the region and be capable of sustaining healthy plant life. Soil shall be free from deleterious substances such as road base, litter, refuse, toxic waste, stones larger than 1 inch in size, coarse sand, heavy or stiff clay, brush, sticks, grasses, roots, noxious weed seed, weeds, and other substances detrimental to plant, animal, and human health.

Planting soil must be derived from a combination of the following types of materials:

1. Nutrient rich topsoil that promotes long-term plant growth
2. US Composting Council STA Program Approved compost
3. Added minerals, nutrients or fertilizers following the specific job requirements

Topsoil shall contain materials that maintain or improve soil organic matter content in a manner that does not contribute to the contamination of crops, soil, or water by plant nutrients, pathogenic organisms, heavy metals, or residues of prohibited substances.

The quality characteristics of the planting soil must have the values shown in the following table unless written consent from the City of Reno Urban Forester to accept soil with qualities outside of this range:

Table 1

Quality Characteristic	Planting Soil Requirement
pH	5.8–8.5
Sodium	< 200 ppm
Nitrogen	Min 50 ppm
Phosphorus	Min 50 ppm
Potassium	Min 50 ppm
Calcium	Min 1,000 ppm
Trace Minerals Sufficient For Plant Growth	
Boron	< 5 ppm
C.E.C. meq/100g	12–24
Organic matter content (% available)	Min 2%
Physical contaminants (% volume)	combined total:
Plastic, glass, metal, rocks < 1"	< .1



STANDARD DETAILS FOR PUBLIC WORKS CONSTRUCTION

DRAWING No.

**SOIL COMPOSITION
SPECIFICATIONS**

R-500L

APPROVED BY: MB | DATE: 12/2019

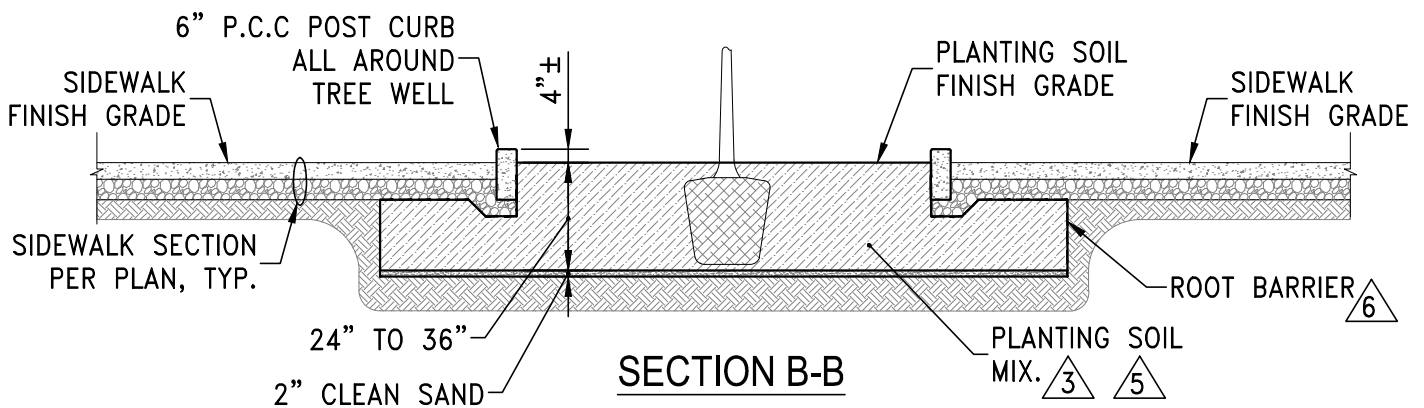
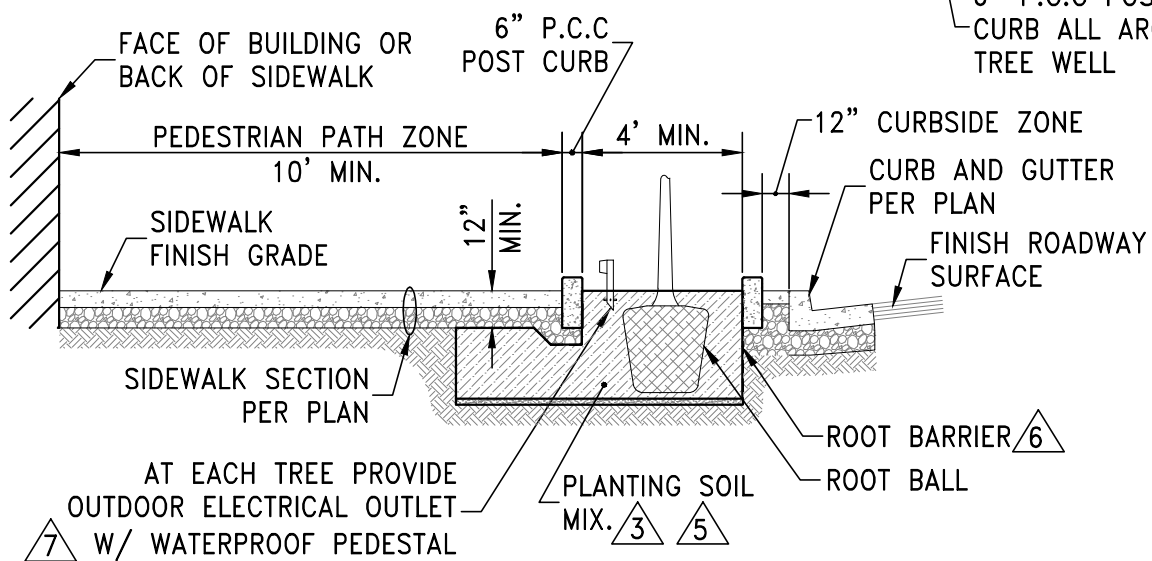
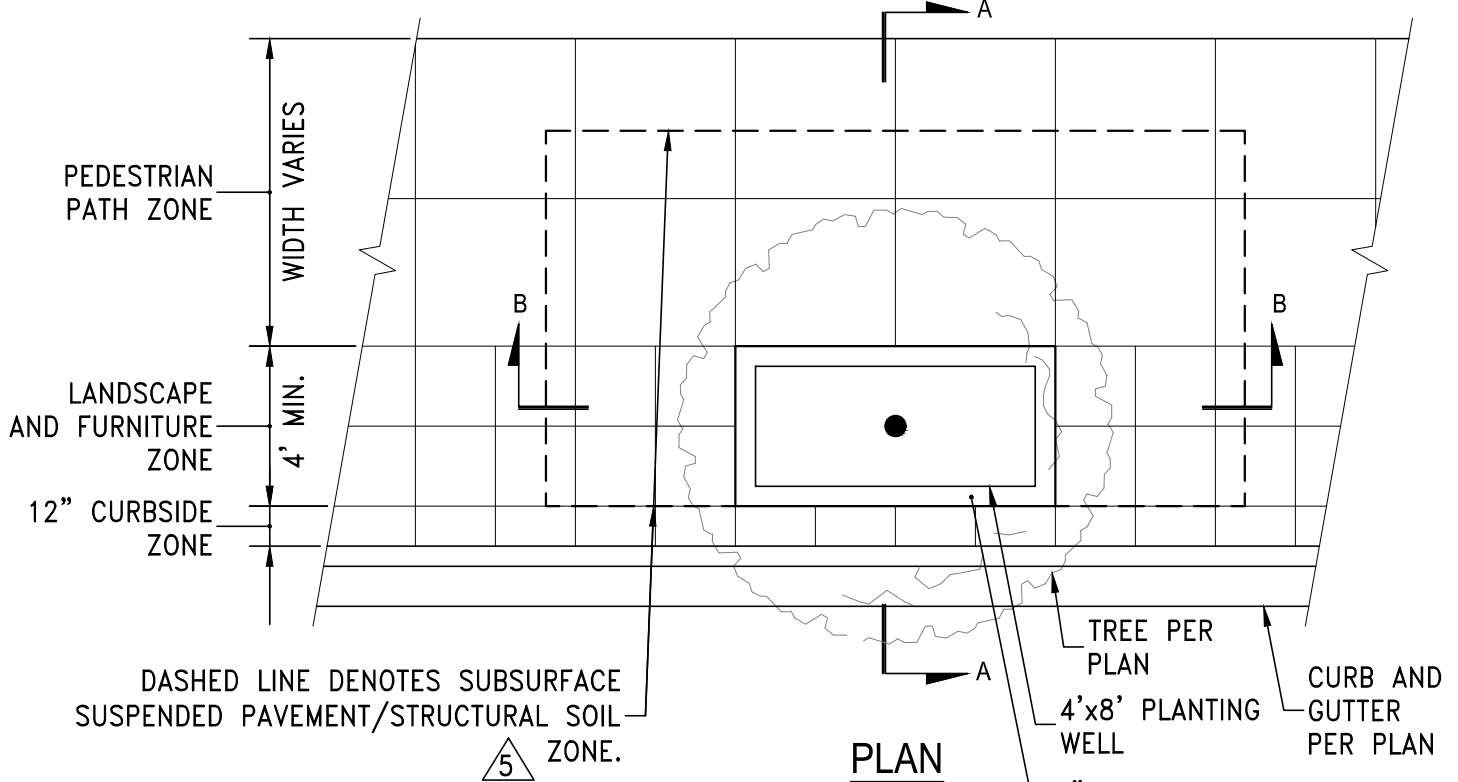

STANDARD DETAILS FOR PUBLIC WORKS CONSTRUCTION

DRAWING No.

TREE WELL WITH CURB

R-501A

APPROVED BY: MB DATE: 12/2019

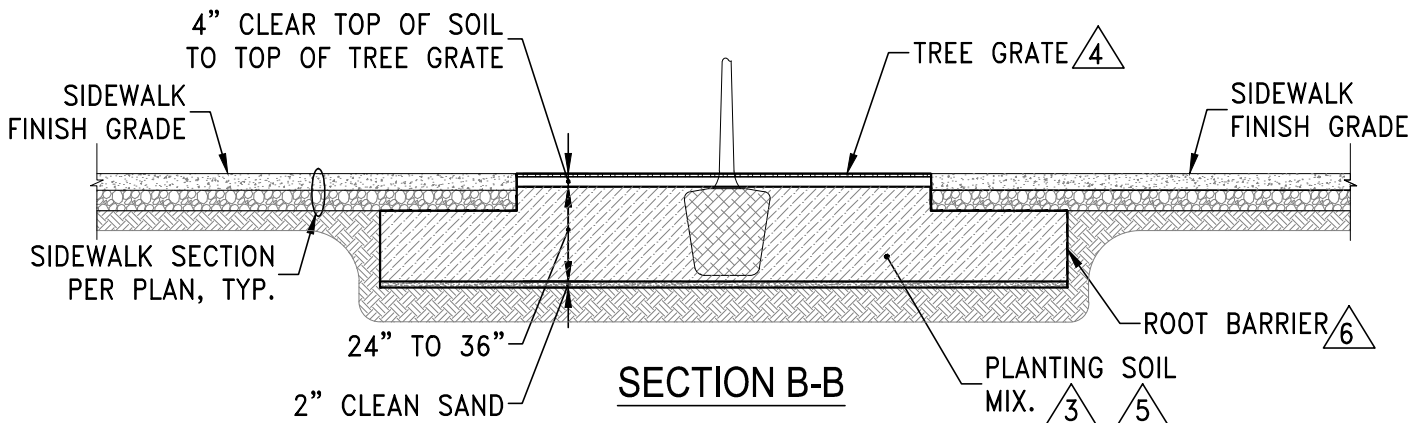
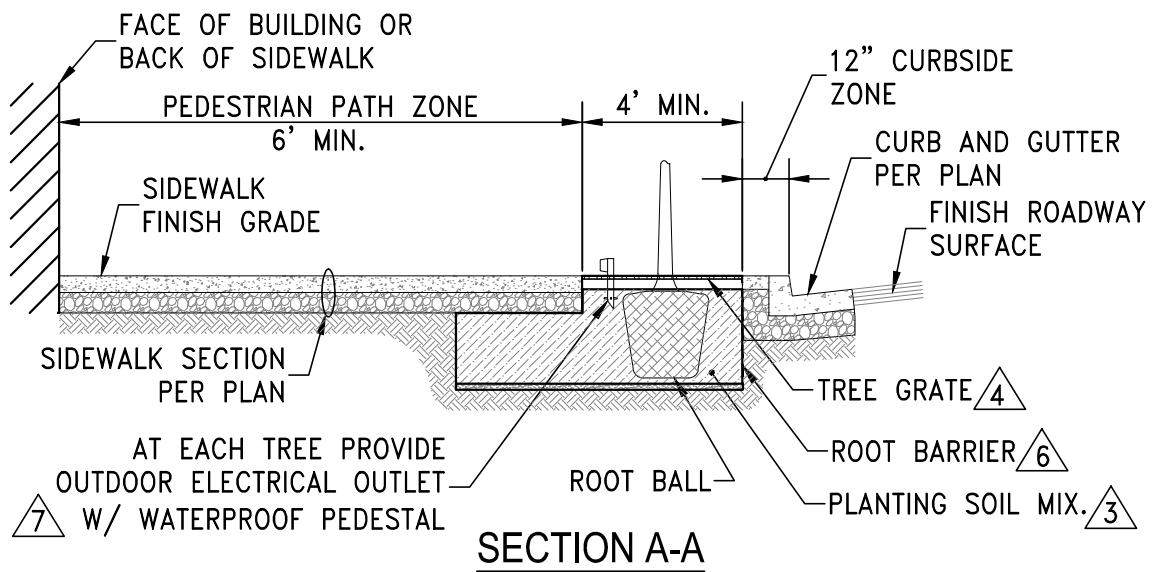
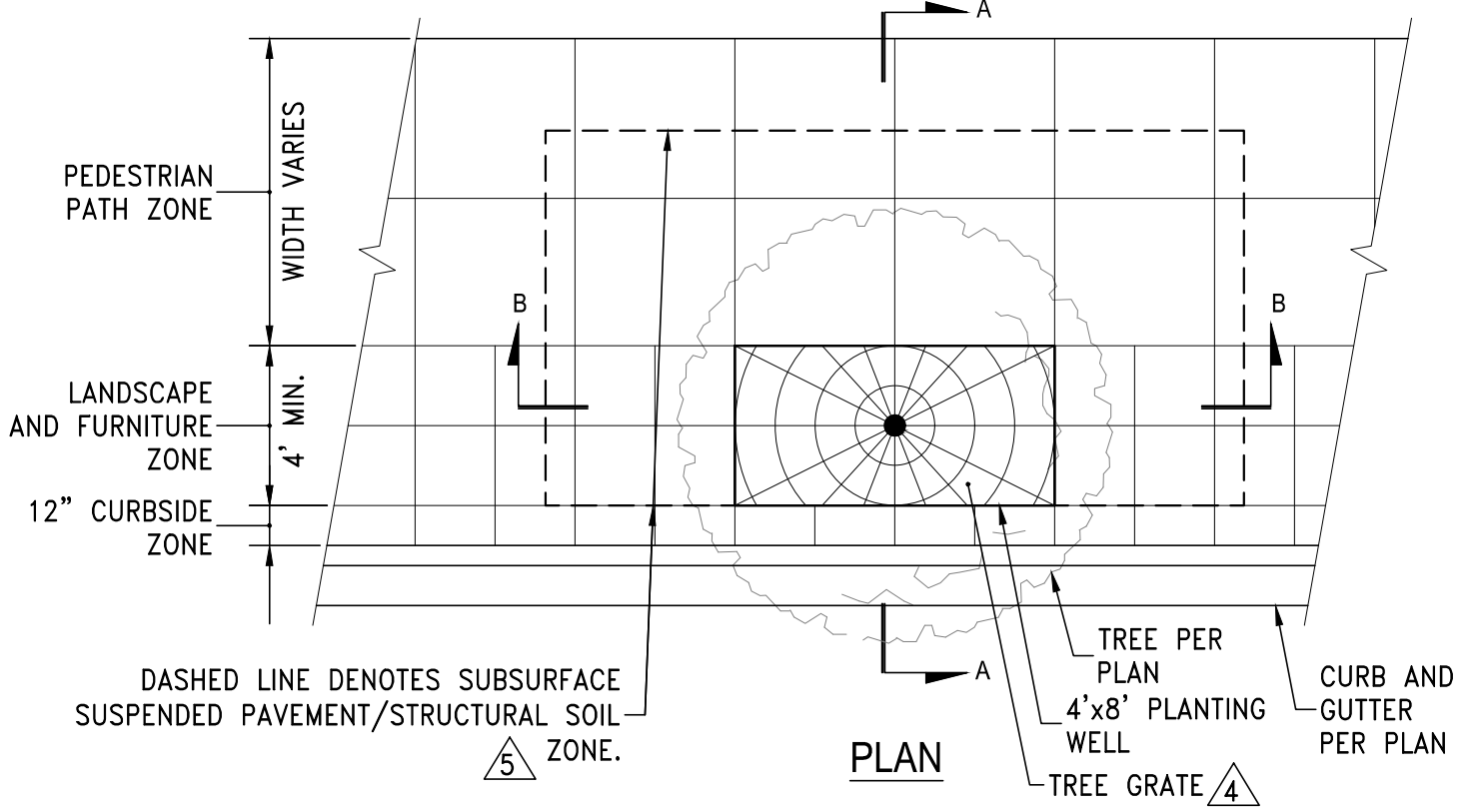

STANDARD DETAILS FOR PUBLIC WORKS CONSTRUCTION

TREE WELL WITH GRATE

DRAWING No.

R-501B

APPROVED BY: MB

DATE: 12/2019

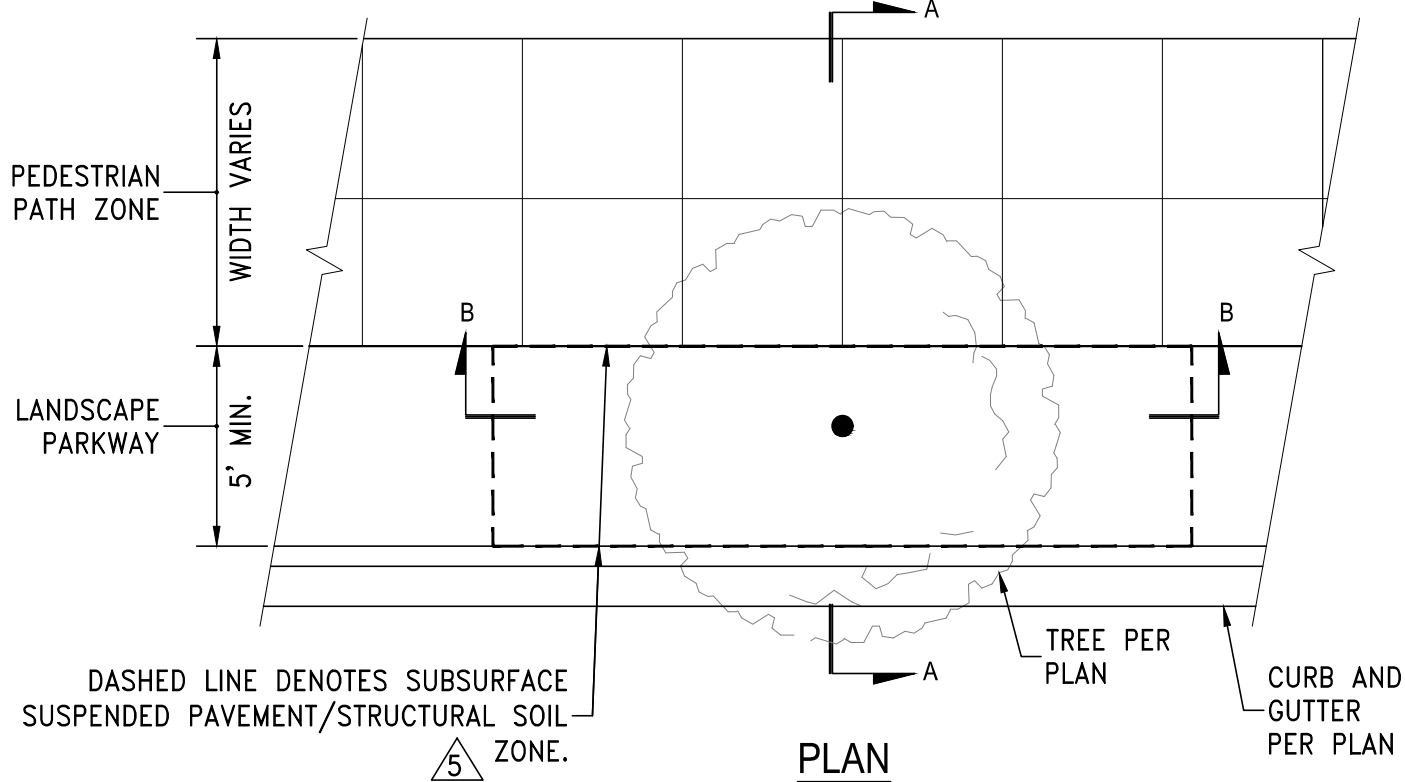

PLAN

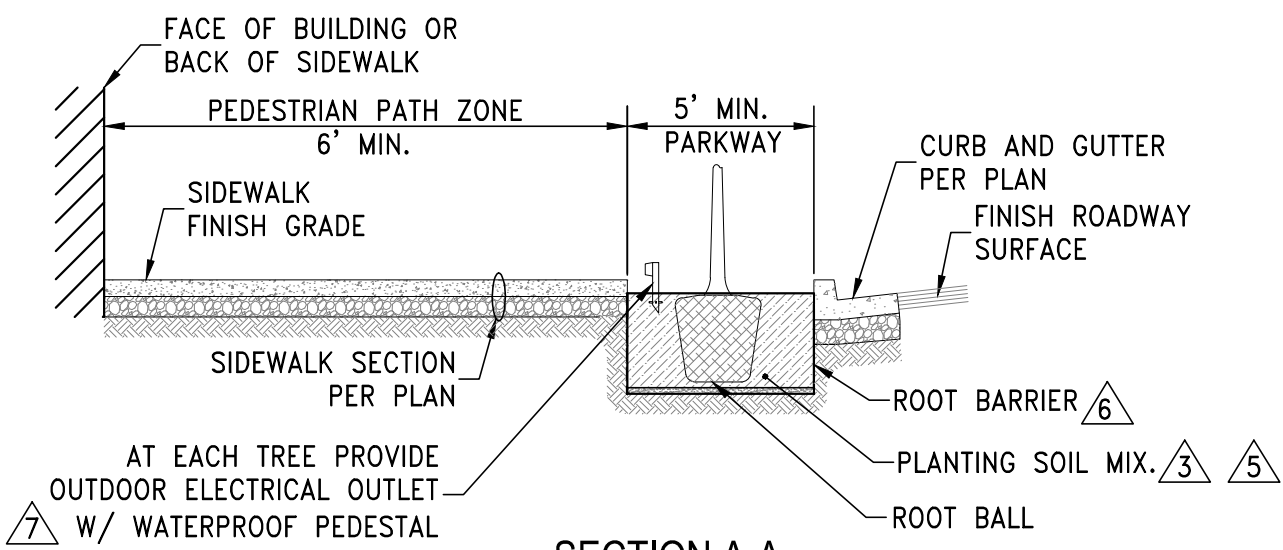

SECTION A-A

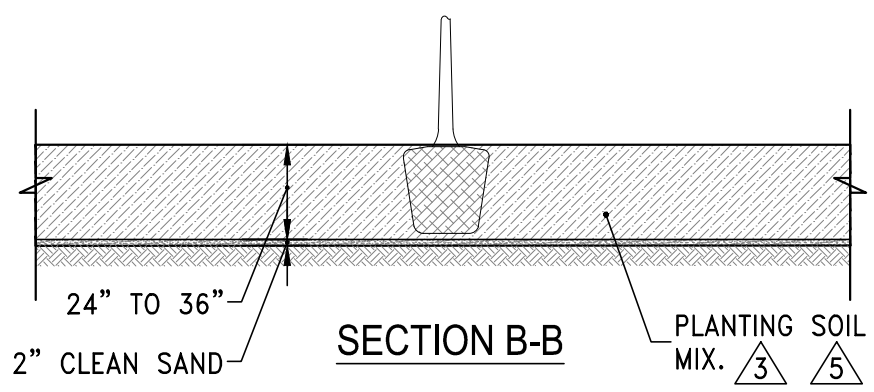

SECTION B-B



STANDARD DETAILS FOR PUBLIC WORKS CONSTRUCTION

DRAWING No.

TREE WITH PARKWAY

R-501C

APPROVED BY: MB | DATE: 12/2019

1. TREE WELL DETAILS ARE NOT INTENDED TO PROVIDE ALL NECESSARY INFORMATION FOR TREE PLANTING AND SHALL BE USED IN CONJUNCTION WITH LANDSCAPE IMPROVEMENT PLANS, DETAILS AND SPECIFICATIONS. REFER TO LANDSCAPE PLANS AND SPECIFICATIONS FOR ADDITIONAL INFORMATION.
2. TREE SPACING PER THE CITY OF RENO DOWNTOWN STREETScape DESIGN MANUAL OR RENO MUNICIPAL CODE. TREES SHALL BE INSTALLED PER THE LANDSCAPE PLANS AND DETAILS.
3. PLANTING SOIL MIX SHALL BE AN AMENDED SOIL/PLANTING MIX APPROVED BY THE CITY OF RENO URBAN FORESTER PRIOR TO PLACEMENT, SEE DETAILS R-500K AND R-500L. PLACEMENT OF SOIL SHALL CONFORM TO THE CITY DETAILS, LANDSCAPE PLANS, AND SPECIFICATIONS.
4. TREE GRATES SHALL BE NEENAH R-8815-A EXTENDED COLLECTION TREE GRATE OR APPROVED EQUAL. GRATES SHALL BE INSTALLED PER MANUFACTURERS SPECIFICATIONS.
5. SOIL TREATMENT ZONE LIMITS VARY AND ARE DETERMINED BY THE MINIMUM SOIL VOLUME CATEGORY OF SELECTED TREE SIZE CLASS, PER THE CITY OF RENO URBAN TREE LIST, SEE DETAILS R-500D THROUGH R-500I. THE REQUIRED SOIL VOLUME MAY BE ACHIEVED BY INSTALLING URBAN FORESTER APPROVED STRUCTURAL SOIL OR APPROVED SUSPENDED PAVEMENT SYSTEM INSTALLED PER MANUFACTURER SPECIFICATIONS. OTHER PRODUCTS OR METHODS SHALL BE SUBMITTED AND APPROVED BY THE URBAN FORESTER PRIOR TO ISSUANCE OF BUILDING PERMIT.
6. ROOT BARRIERS SHALL BE INSTALLED TO PROTECT ADJACENT HARDSCAPE. REFER TO LANDSCAPE PLANS AND SPECIFICATIONS.
7. PROVIDE WEATHERPROOF PEDESTAL WITH GFCI OUTLET. AN ACCEPTABLE PRODUCT IS GARD-N-POST ENCLOSURE, BLACK OR APPROVED EQUAL. PRODUCT AND INSTALLATION SHALL CONFORM TO REQUIREMENTS OF NATIONAL ELECTRICAL CODE (NEC). POWER FOR THE OUTLET SHALL BE SUPPLIED BY MAINTENANCE ORGANIZATION POWER SOURCE.



STANDARD DETAILS FOR PUBLIC WORKS CONSTRUCTION

DRAWING No.

NOTES - TREE WELLS

R-501D

APPROVED BY: MB | DATE: 12/2019

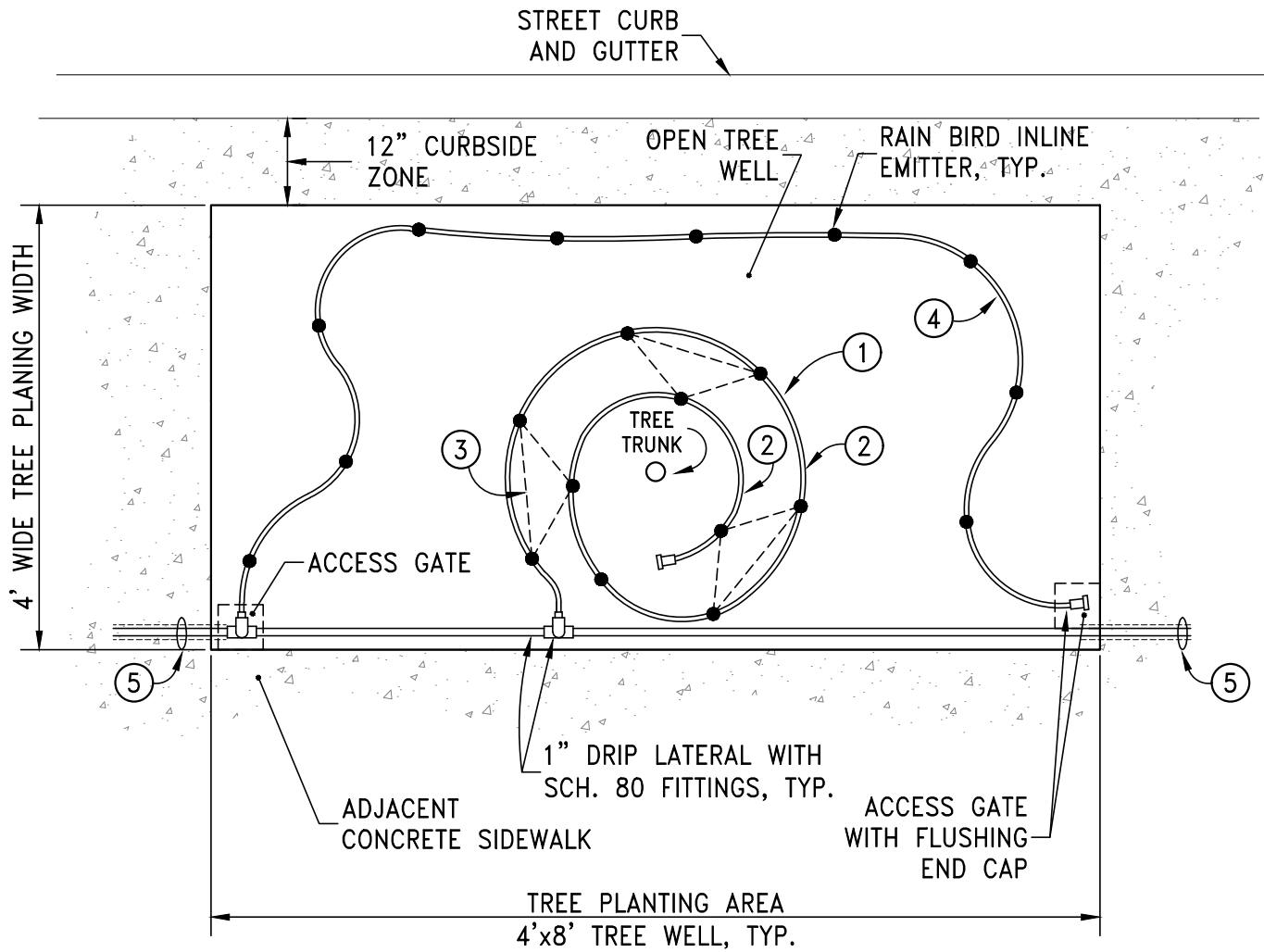

PLAN

NOTES:

- ① RAIN BIRD XF SERIES (XFD-09-24) DRIPLINE WITH (10) EMITTERS PER TREE AT 0.90 GPH = 9.0 GPH PER TREE WITH FLUSHING END CAP (MDCFCAP)
- ② PLACE FIRST RING 12" FROM TREE TRUNK AND PLACE SECOND RING 28" FROM THE TREE TRUNK.
- ③ LAYOUT DRIPLINE TO CREATE TRIANGULAR SPACING PATTERN WITH INLINE EMITTERS, TYP.
- ④ FUTURE TREE MATURITY IRRIGATION. RAIN BIRD INLINE EMITTER WITH (10) 0.92 GPH INLINE EMITTERS AT 24" SPACING. ACTIVATE FOR FUTURE USE.
- ⑤ PROVIDE 2" MIN. SCH. 40 PVC SLEEVE WITH 1" MIN. SALCO LATERAL RUNNING BETWEEN OPEN TREE WELLS AT 18" MIN. DEPTH.



STANDARD DETAILS FOR PUBLIC WORKS CONSTRUCTION

TREE WELL DRIP IRRIGATION

DRAWING No.

R-520A

APPROVED BY: MB | DATE: 12/2019

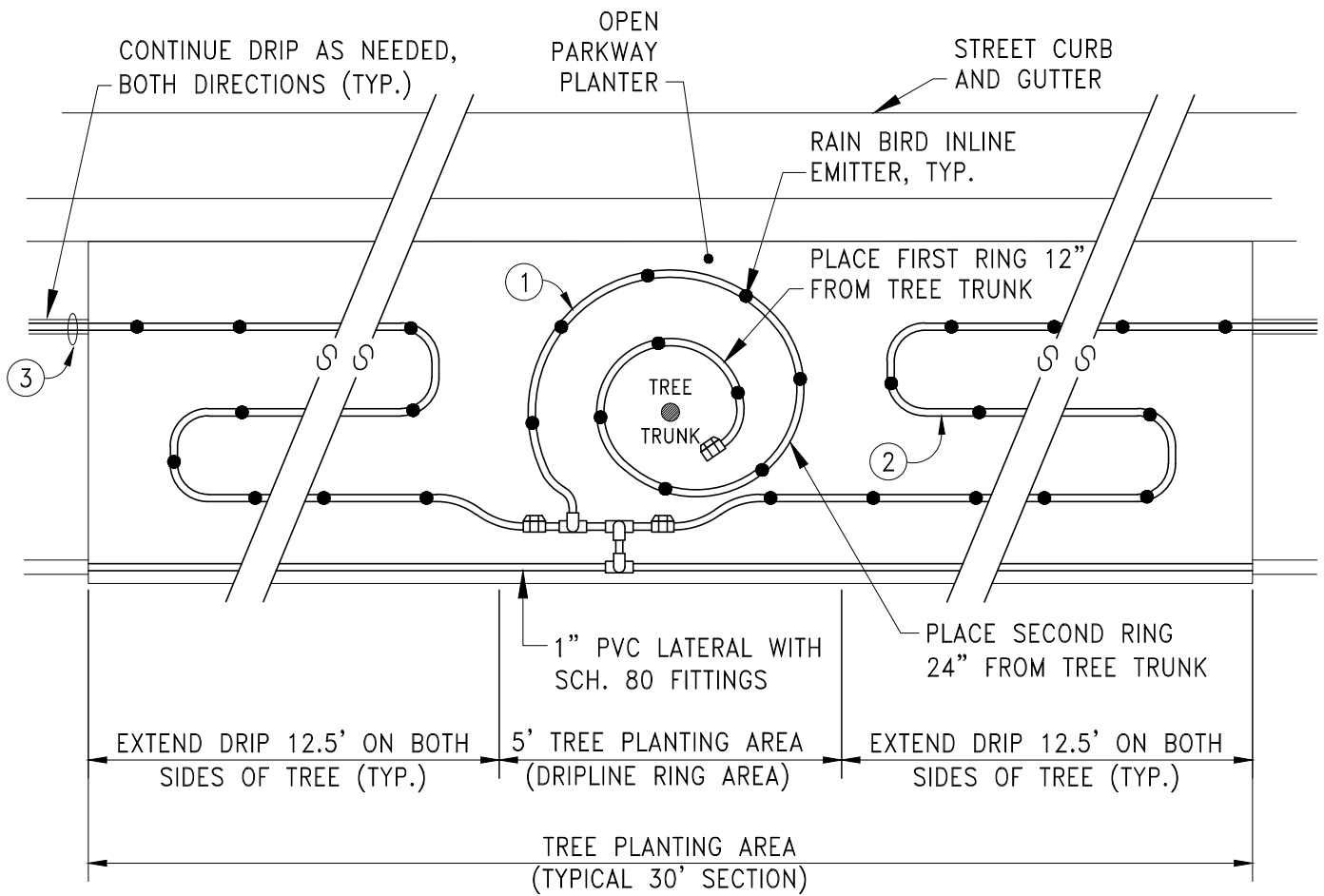

PLAN

APPROX. FLOW PER TREE (TYPICAL 30' SECTION) = 0.9 GPM

NOTES:

- ① RAIN BIRD XF SERIES (XFD-09-18) DRIPLINE WITH 10 EMITTERS PER TREE AT 0.90 GPH = 9.0 GPH PER TREE WITH FLUSHING END CAP (MDCFCAP)
- ② EXPANDED XF SERIES DRIPLINE (XFD-09-18) FOR FUTURE TREE MATURITY IRRIGATION OR SHRUBS = 45 GPH.
- ③ PROVIDE 2" MIN. SCH. 40 PVC SLEEVE WITH 1" MIN. SALCO LATERAL (AS APPLICABLE) RUNNING BETWEEN OPEN TREE PITS AT 18" MIN. DEPTH.
- ④ 1/2" (THREAD BY THREAD) PVC BALL VALVE WITH RAINBIRD XFFTMA050 INSERT BY 1/2" MALE MPT ADAPTOR FITTINGS

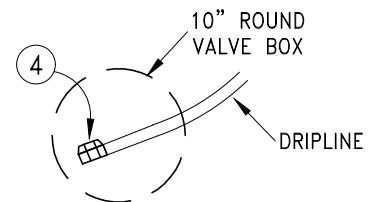

INSTALL BALL VALVE FOR FLUSHING AT END OF ALL DRIPLINE RUNS

DETAIL A



STANDARD DETAILS FOR PUBLIC WORKS CONSTRUCTION

DRAWING No.

PARKWAY DRIP IRRIGATION

R-520B

APPROVED BY: MB DATE: 12/2023

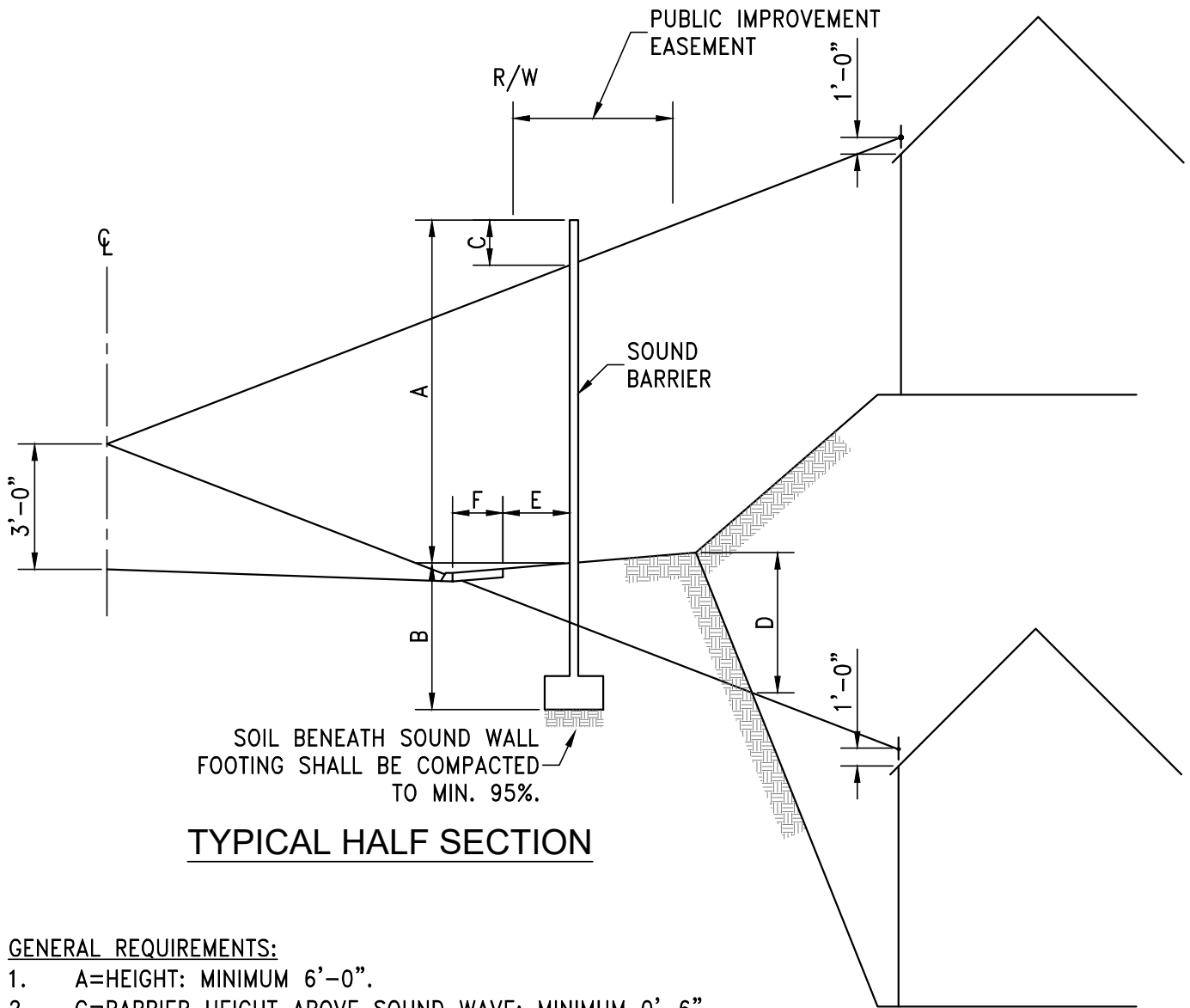

TYPICAL HALF SECTION

GENERAL REQUIREMENTS:

1. A=HEIGHT: MINIMUM 6'-0".
2. C=BARRIER HEIGHT ABOVE SOUND WAVE: MINIMUM 0'-6".
3. D=EARTH BERM: WHEN EARTH BERM EXCEEDS 2'-0" ABOVE SOUND WAVE, BARRIER IS NOT REQUIRED.
4. DRAINAGE COLLECTED FROM TWO OR MORE LOTS IS TO BE COLLECTED AND PIPED ALONG BACK OF BARRIER TO A STORM DRAIN SYSTEM.

ADDITIONAL REQUIREMENTS:

5. B=DEPTH OF FOOTING BELOW GROUND: MINIMUM 2'-0".
6. E=LANDSCAPING STRIP: MINIMUM 4'-6".
7. F=SIDEWALK WIDTH: CONSTRUCT SIDEWALK FULL WIDTH BETWEEN BACK FACE OF CURB AND FACE OF WALL WHEN LANDSCAPING STRIP IS NOT REQUIRED: MINIMUM 5'-0".
8. THE CITY OF RENO'S PLANNING DEPARTMENT SHALL APPROVE THE COLORS AND TEXTURES ON THE FRONT FACE OF THE SOUND BARRIER.
9. BARRIER PLANS ARE TO BE STAMPED AND SIGNED BY A NEVADA REGISTERED CIVIL ENGINEER, VERIFYING TO THE INTEGRITY OF THE STRUCTURAL DESIGN.
10. BARRIERS WILL BE OWNED AND MAINTAINED BY THE CITY WHERE A HOMEOWNER'S ASSOCIATION DOES NOT EXIST.
11. LANDSCAPING ALONG FRONT FACE OF BARRIER WILL BE MAINTAINED BY THE CITY WHERE A HOMEOWNER'S ASSOCIATION DOES NOT EXIST.



STANDARD DETAILS FOR PUBLIC WORKS CONSTRUCTION

DRAWING No.

SOUND BARRIER

R-601

APPROVED BY: JF DATE: 12/2019

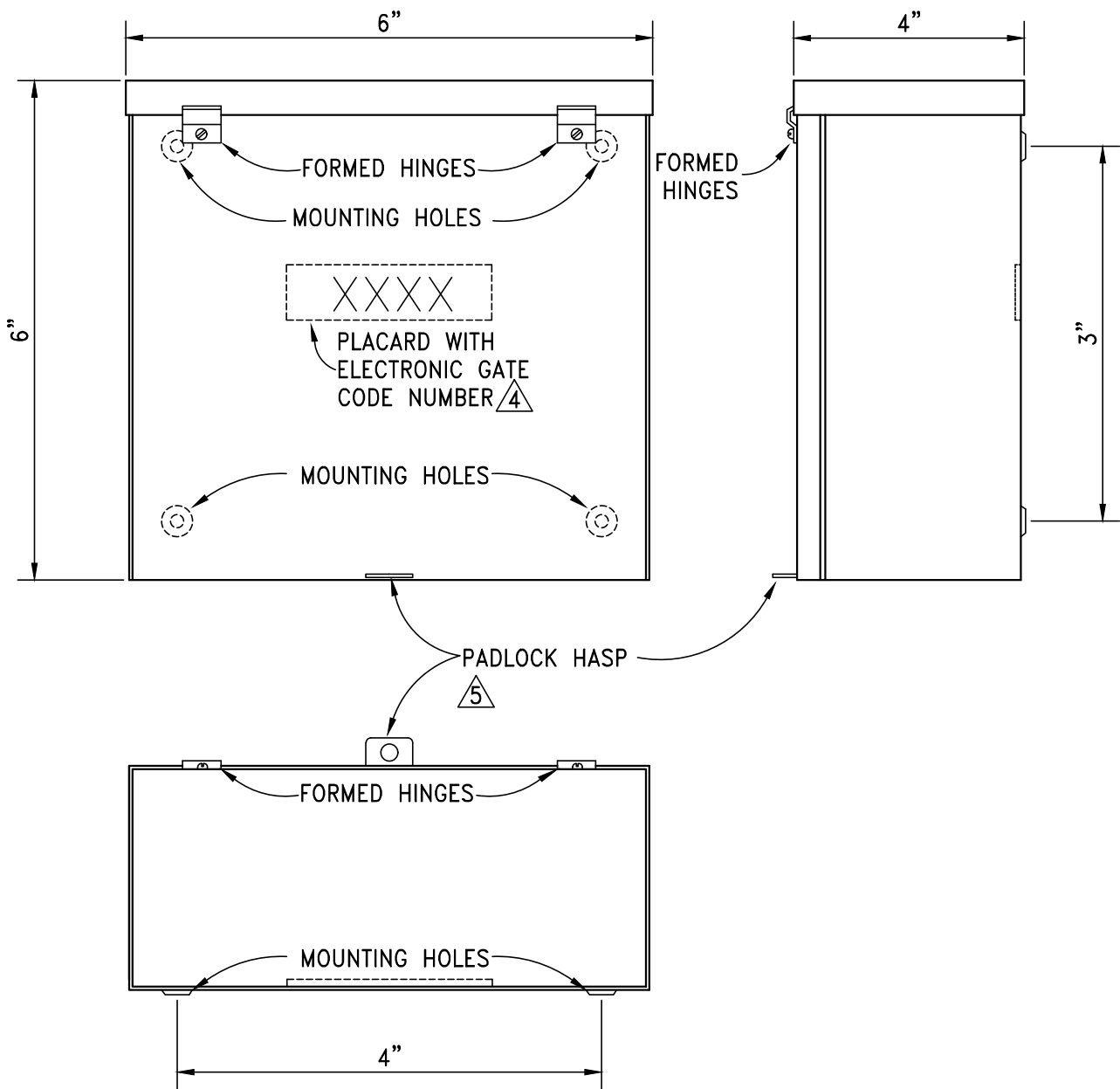

NOTES:

1. THIS BOX IS INTENDED FOR INSTALLATION AT GATED COMMUNITIES WITH ELECTRONICALLY CONTROLLED ACCESS GATES, WHERE ACCESS BY THE CITY OF RENO PERSONNEL IS REQUIRED.
 2. THIS BOX IS TO BE INSTALLED ADJACENT TO THE VEHICLE ENTRANCE GATE, ACCESSIBLE BY PERSONNEL FROM THE OUTSIDE PERIMETER.
 3. THE ELECTRONIC GATE ACCESS BOX IS TO BE A "B-LINE" TYPE 3R HINGE COVER ENCLOSURE, PART NO. 664 RTHC NK, OR APPROVED EQUIVALENT.
- △4 A PLACARD WITH THE CODE FOR THE ELECTRONIC VEHICLE SECURITY GATE IS TO BE MOUNTED INSIDE THE BOX.
- △5 THE CITY OF RENO IS TO PROVIDE THE PADLOCK AND MAINTAIN THE KEYS.



STANDARD DETAILS FOR PUBLIC WORKS CONSTRUCTION

**ELECTRONIC GATE
ACCESS BOX**

DRAWING No.

R-602

APPROVED BY: JF | DATE: 12/2019

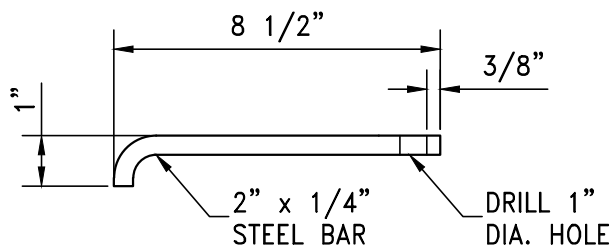
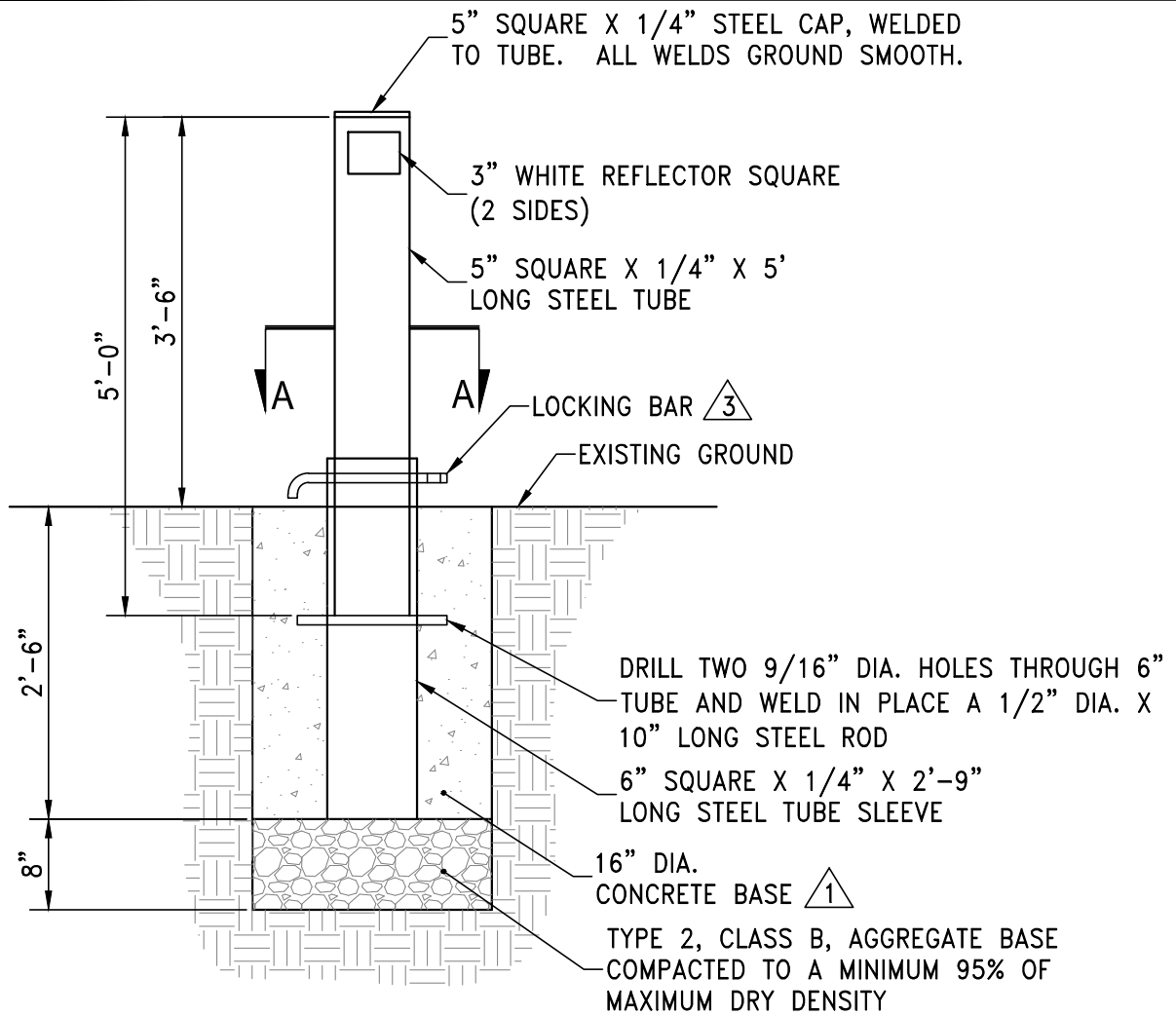

LOCKING BAR

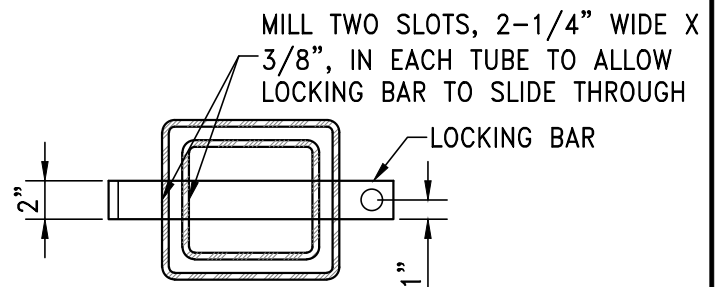

SECTION A-A

NOTES:

- $\triangle 1$. PORTLAND CEMENT CONCRETE (P.C.C.) SHALL BE 4000 PSI MIN. COMPRESSIVE STRENGTH AT 28 DAYS. ALL CEMENT CONCRETE SHALL HAVE A COARSE AGGREGATE GRADATION CONFORMING TO SIZE No. 67. POLYPROPYLENE OR CELLULOSE FIBERS SHALL BE ADDED TO THE P.C.C. AT 1.5 LBS PER CUBIC YARD. MIX DESIGN SHALL CONFORM TO THE REQUIREMENTS OF SECTION 337.10 OF SSPWC. ALL MATERIALS SHALL CONFORM TO SSPWC.
2. ALL WELDS AND BENDS SHALL BE SMOOTH, EVEN AND PAINTED YELLOW, MATCHING ENNIS-FLINT YELLOW 1952F COLOR.
- $\triangle 3$. CONTACT THE CITY OF RENO PUBLIC WORKS DEPARTMENT FOR PADLOCK DETAILS. THE CITY OF RENO SHALL MAINTAIN ALL KEYS.



STANDARD DETAILS FOR PUBLIC WORKS CONSTRUCTION

DRAWING No.

REMOVABLE BOLLARD

R-603A

APPROVED BY: KK

DATE: 2/2026

NOTES:

STERNBERG - RICHMOND
 QUICK RELEASE BOLLARD
 #390/B/QR/VG
 COLOR: VERDE GREEN

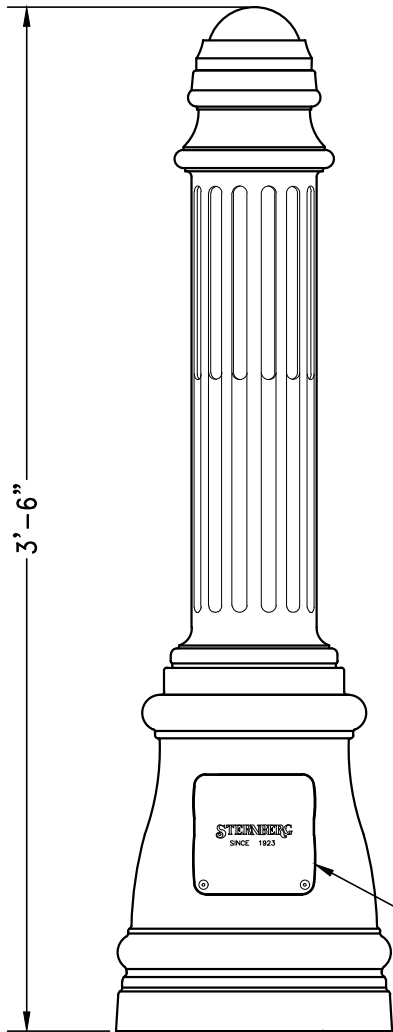

1. GENERAL
 THE BOLLARD SHALL BE CAST ALUMINUM, ONE-PIECE CONSTRUCTION. THE 11½" DIAMETER CAST ALUMINUM FLUTED BASE SHALL BE CONSTRUCTED WITH A 5¼" DIAMETER STRAIGHT FLUTED CAST ALUMINUM SHAFT. THE MODEL SHALL BE STERNBERG LIGHTING #390B-QR QUICK RELEASE UNIT BOLLARD, RICHMOND.
2. CONSTRUCTION
 THE BASE SHALL BE DESIGNED WITH A SCULPTURE BELL SHAPED BOTTOM, FOURTEEN FLUTE TOP SECTION AND BE MADE OF HEAVY 356 ALLOY CAST ALUMINUM. IT SHALL HAVE A ¾" THICK FLOOR CAST AS AN INTEGRAL PART OF THE BASE. THE BOLLARD CAP SHALL BE WELDED IN PLACE. THE OVERALL HEIGHT OF THE BOLLARD SHALL BE 42".
3. QUICK RELEASE MOUNT
 THE MODEL 390B-QR SHALL HAVE A QUICK RELEASE OPTION WHICH ALLOWS QUICK REMOVAL OF THE BOLLARD FOR CONVENIENCE OR EMERGENCY ACCESS. THE BURIAL PORTION SHALL BE MADE OF ASTM 6061 ALUMINUM EXTRUSION AND SHALL HAVE A KEYWAY AND FLEXIBLE CONNECTION SYSTEM FOR SECURING TO BOLLARD. THE BOLLARD SHALL HAVE A MATED EXTENSION AND ANTI-ROTATION KEY AND PADLOCK SLOT. THE QUICK RELEASE SYSTEM SHALL ALLOW FOR A FLUSH PAVEMENT INSTALLATION AFTER TEMPORARY BOLLARD REMOVAL.
4. FINISH
 OUR OPTIONAL ANTIQUE VERDE GREEN FINISH ARE HAND BRUSHED USING A 3-STEP PROCESS. THE TOTAL ASSEMBLY SHALL BE WRAPPED IN SHOCKPROOF WRAPPING OR FULLY ENCLOSED IN CORRUGATED CARTONS.
5. INSTALLATION
 FOUR, HOT DIPPED GALVANIZED "L" TYPE ANCHOR BOLTS SHALL BE PROVIDED WITH THE POST FOR NON-QUICK RELEASE BOLLARD ANCHORAGE. QUICK RELEASE ANCHORAGE REQUIRES NO ANCHOR BOLTS. A DOOR SHALL BE PROVIDED FOR ANCHOR BOLT ACCESS. IT SHALL BE SECURED WITH TAMPER PROOF, STAINLESS STEEL HARDWARE.
6. PLACE ACCESS DOOR AWAY FROM STREET.

1 1/2" DIA. BASE .750
 FLOOR THICKNESS 4
 ANCHOR BOLTS

ACCESS DOOR WITH FLUSH
 STAINLESS STEEL ALLEN
 HEAD SCREWS.



STANDARD DETAILS FOR PUBLIC WORKS CONSTRUCTION

DRAWING No.

DECORATIVE BOLLARD

R-603B

APPROVED BY: KK DATE: 1/2023

NOTES:

1. GREASE PORTION OF BARS EXTENDING ACROSS JOINT AND PROVIDE CAP OR SLEEVE ON END TO PERMIT MOVEMENT.
2. COVER EARTH SIDE OF JOINT WITH A STRIP OF MEMBRANE WATERPROOFING TO PREVENT SEEPAGE THROUGH JOINT.
3. PROVIDE 12" THICK 3/4" DRAIN ROCK BEHIND WALL.
4. SEE MASONRY RETAINING WALL DETAILS R-504B AND MASONRY RETAINING WALL NOTES, R-504C AND R-504D

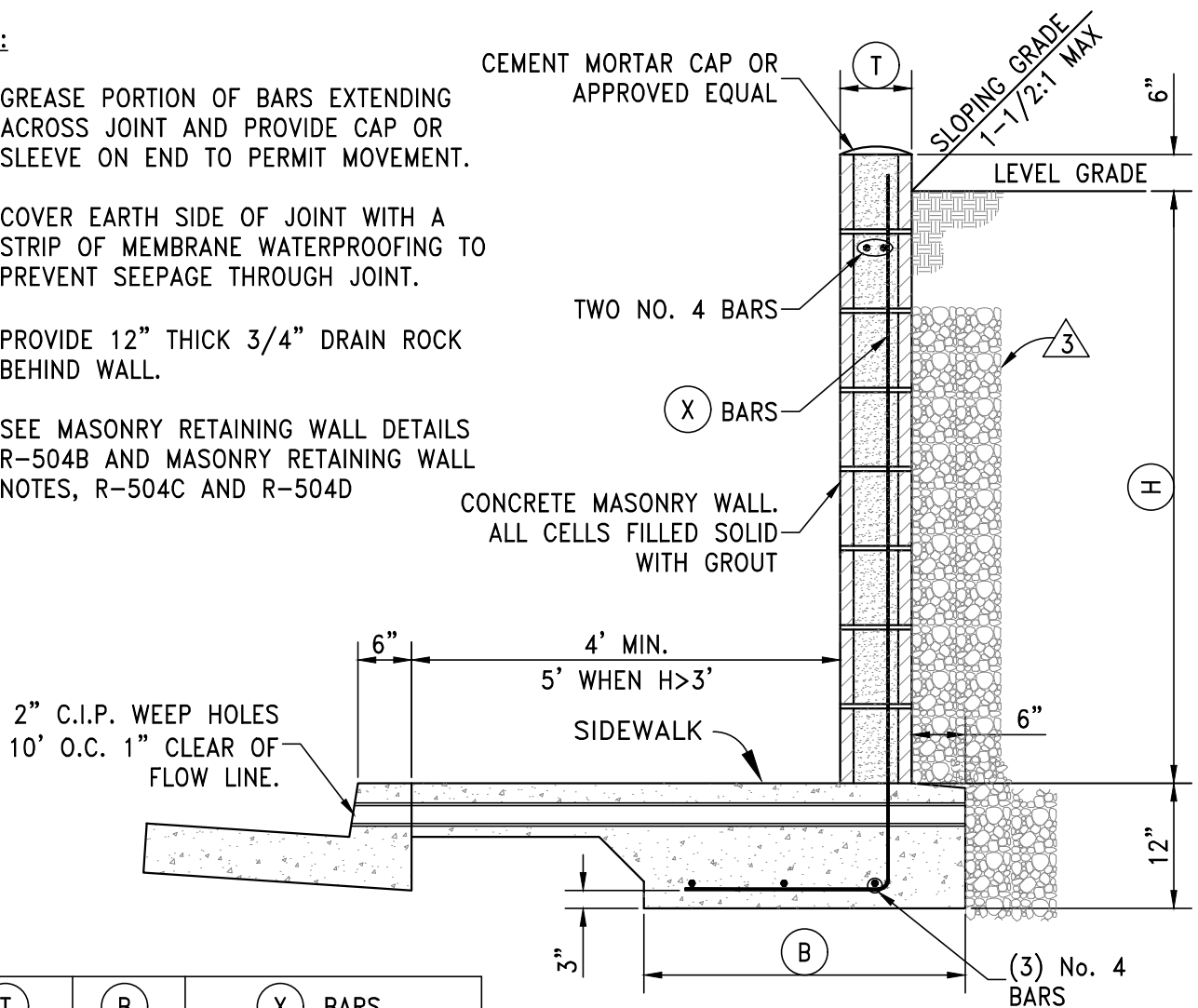

TYPICAL SECTION 5' MAX

(H)	(T)	(B)	(X) BARS
1	7 5/8"	1'-8"	No. 4 AT 24" O.C.
2	7 5/8"	1'-8"	No. 4 AT 24" O.C.
3	7 5/8"	2'-3"	No. 4 AT 24" O.C.
4	7 5/8"	3'-0"	No. 4 AT 24" O.C.
5	7 5/8"	3'-6"	No. 5 AT 16" O.C.

SLOPING GRADE

(H)	(T)	(B)	(X) BARS
1	7 5/8"	1'-2"	No. 4 AT 32" O.C.
2	7 5/8"	1'-2"	No. 4 AT 32" O.C.
3	7 5/8"	1'-9"	No. 4 AT 32" O.C.
4	7 5/8"	2'-2"	No. 4 AT 32" O.C.
5	7 5/8"	2'-9"	No. 4 AT 24" O.C.

LEVEL GRADE

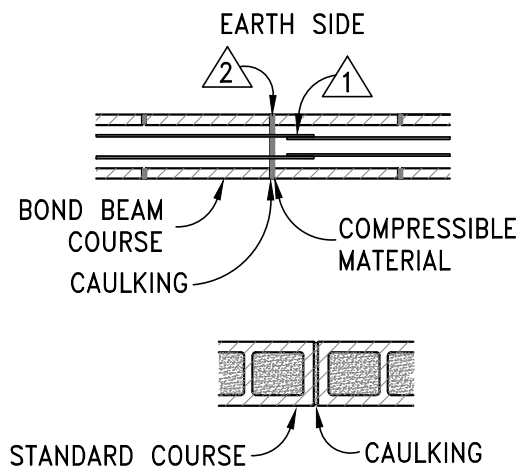

TYPICAL EXPANSION JOINT DETAIL



STANDARD DETAILS FOR PUBLIC WORKS CONSTRUCTION

MASONRY RETAINING WALLS I-L & S

DRAWING No.

R-604A

APPROVED BY: JF DATE: 12/2019

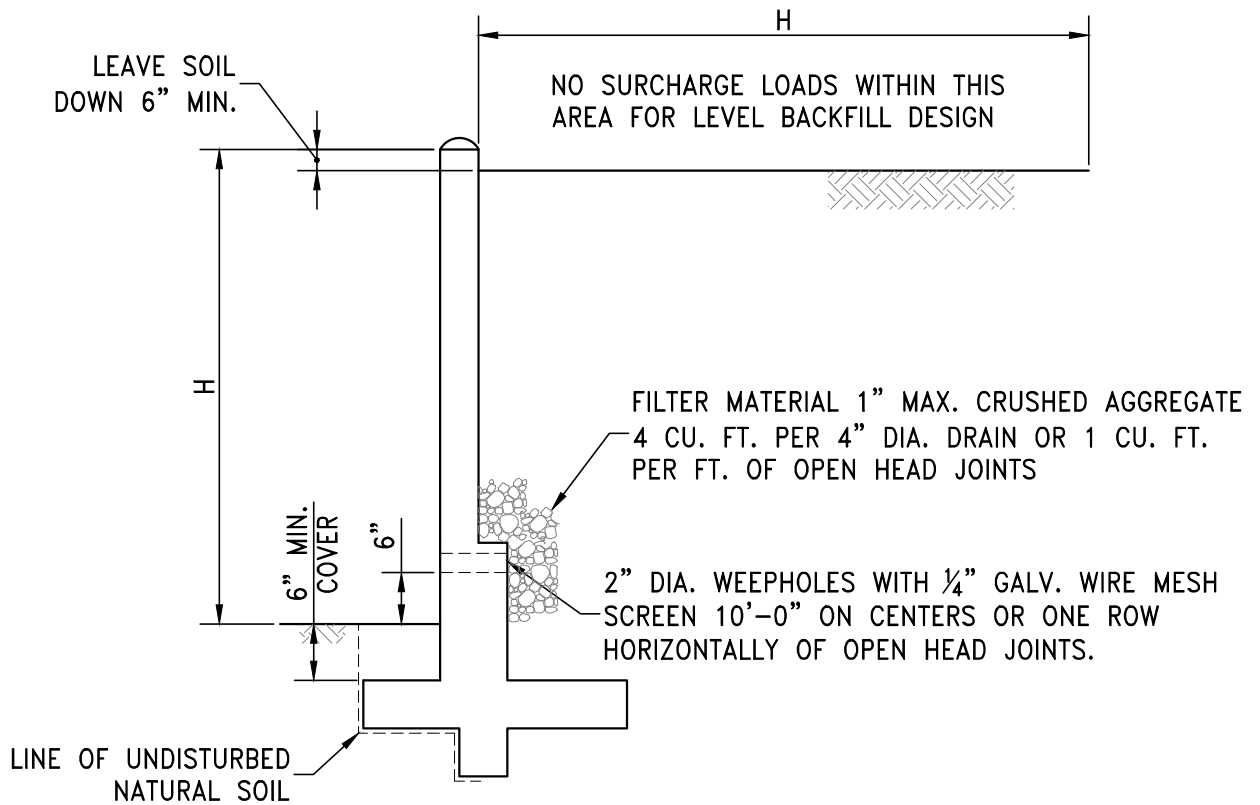

TYPICAL SECTION

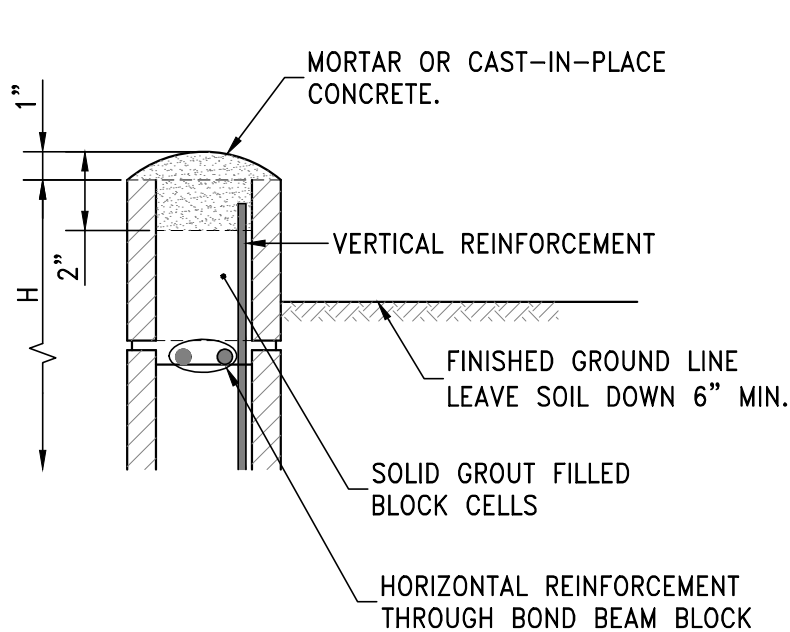

CAP DETAIL

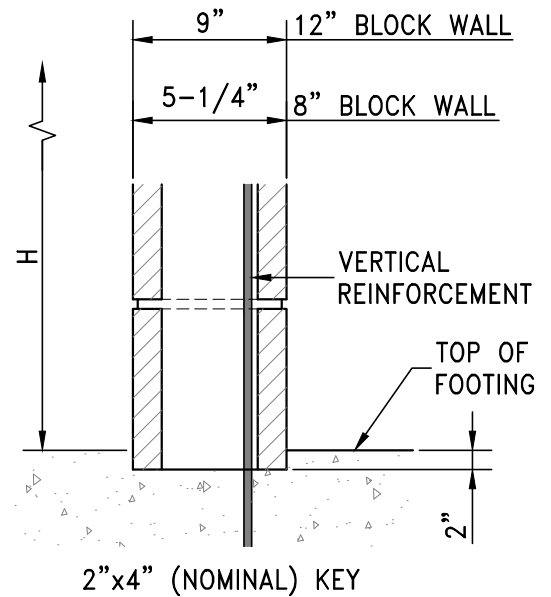

KEY DETAIL

NOTE:
ALL MASONRY RETAINING WALLS SHALL BE CONSTRUCTED WITH CAP, KEY AND DRAINAGE DETAILS AS SHOWN HEREON.



STANDARD DETAILS FOR PUBLIC WORKS CONSTRUCTION

MASONRY RETAINING WALLS

DRAWING No.

R-604B

APPROVED BY: JF | DATE: 12/2019

1. WALL TYPES:

- I-TOE SUPPORT
- II-HEEL SUPPORT
- III-TOE AND HEEL SUPPORT
- L-LEVEL BACKFILL
- S-SLOPING BACKFILL

2. DESIGN CONDITIONS:

WALLS ARE TO BE USED FOR THE LOADING CONDITIONS SHOWN FOR EACH TYPE WALL. DESIGN H SHALL NOT BE EXCEEDED. FOOTING KEY IS REQUIRED EXCEPT AS SHOWN OTHERWISE. SPECIAL FOOTING DESIGN IS REQUIRED WHERE FOUNDATION MATERIAL IS INCAPABLE OF SUPPORTING TOE PRESSURE LISTED IN TABLES.

3. REINFORCEMENT:

INTERMEDIATE GRADE, HARD GRADE OR RAIL STEEL DEFORMATION SHALL CONFORM TO ASTM A615, A616, A617. BARS SHALL LAP 40 DIAMETERS, WHERE SPLICED, UNLESS OTHERWISE SHOWN ON PLANS. BENDS SHALL CONFORM TO THE MANUAL OF STANDARD PRACTICE, A.C.I. BACKING FOR HOOKS IS FOUR BAR DIAMETERS. ALL BAR EMBEDMENTS ARE CLEAR DISTANCES TO OUTSIDE OF BARS. SPACING FOR PARALLEL BARS IS CENTER TO CENTER OF BARS. ALL REINFORCING SHALL BE 3" CLEAR UNLESS OTHERWISE SHOWN.

4. MASONRY:

ALL MASONRY SHALL CONFORM TO THE REQUIREMENTS OF SUB-SECTION 311.13 "MASONRY CONSTRUCTION" OF THE "STANDARD SPECIFICATIONS FOR PUBLIC CONSTRUCTION". ALL MASONRY SHALL CONFORM TO THE REGULATIONS OF THE U.B.C.

5. FOOTINGS:

BOTTOM OF FOOTINGS WILL BE PLACED AT LEAST 24" BELOW FINISHED GROUND SURFACE. CHANGES IN FOOTING ELEVATIONS SHALL BE MADE IN EQUAL INCREMENTS OF MASON BLOCK HEIGHT.

6. TESTING:

SUFFICIENT TESTING WILL BE CONDUCTED TO VERIFY DESIGN DATA.

7. DESIGN DATA:

EARTH = 120 PCF AND EQUIVALENT
FLUID PRESSURE = 36 PSF PER
FOOT OF HEIGHT

REINFORCED MASONRY:
F'm = 600 PSI
Fm = 200 PSI
Fs = 20,000 PSI
n = 50

REINFORCED CONCRETE:
Fc = 1,200 PSI
F'c = 3,000 PSI
Fs = 20,000 PSI
n = 10

WALLS SHOWN FOR 1 1/2:1 UNLIMITED SLOPING SURCHARGE ARE DESIGNED IN ACCORDANCE WITH RANKINE'S FORMULA FOR UNLIMITED SLOPING SURCHARGE WITH $\phi=33^{\circ}42'$.



STANDARD DETAILS FOR PUBLIC WORKS CONSTRUCTION

DRAWING No.

NOTES - MASONRY RETAINING WALLS

R-604C

APPROVED BY: JF | DATE: 12/2019

8. CONCRETE:

ALL CONCRETE SHALL BE CLASS AA OR DA.

9. MASONRY MORTAR:

THE MORTAR SHALL CONFORM TO THE REQUIREMENTS OF SUB-SECTION 311.13 "MASONRY CONSTRUCTION" OF THE "STANDARD SPECIFICATION FOR PUBLIC WORKS CONSTRUCTION". MORTAR IN HORIZONTAL JOINTS SHALL FULLY COVER ALL FACE SHELL AND WEB MEMBERS. VERTICAL JOINTS SHALL BE BUTTERED TO A DEPTH GREATER THAN THE THICKNESS OF THE FACE SHELLS OF THE BLOCK. FURROWING OF MORTAR WILL NOT BE PERMITTED.

10. GROUT:

THE GROUT SHALL CONFORM TO THE REQUIREMENTS OF SUB-SECTION 311.13 "MASONRY CONSTRUCTION" OF THE "STANDARD SPECIFICATIONS FOR PUBLIC WORKS CONSTRUCTION". ALL CELLS SHALL BE POURED SOLID WITH GROUT.

11. EXCAVATION AND BACKFILL:

COMPACTION OF BACKFILL MATERIAL BY JETTING OR PONDING WITH WATER WILL NOT BE PERMITTED. EACH LAYER OF BACKFILL SHALL BE MOISTENED TO ITS OPTIMUM AND THOROUGHLY TAMPED, ROLLED OR OTHERWISE COMPACTED TO AT LEAST 90% OF ITS MAXIMUM DRY DENSITY. NO BACKFILL MATERIAL SHALL BE DEPOSITED AGAINST MASONRY RETAINING WALLS UNTIL THE GROUT HAS DEVELOPED A STRENGTH OF 2,000 POUNDS PER SQUARE INCH IN COMPRESSION AS DETERMINED BY TEST 2" CUBES, OR UNTIL THE MASONRY RETAINING WALL HAS CURED FOR A MINIMUM OF 14 DAYS.

12. OPTIONAL MORTAR KEY:

EMBEDMENT OF THE FIRST COURSE OF BLOCK IN A POURED FOOTING MAY BE OMITTED BY PROVIDING A MORTAR KEY. THE KEY IS FORMED BY EMBEDDING A FLAT 2 X 4 FLUSH WITH THE TOP OF THE FRESHLY POURED FOOTING. REMOVE THE 2 X 4 AFTER THE CONCRETE HAS STARTED TO HARDEN.

13. EXPANSION JOINTS:

WALLS OVER 50 FEET IN LENGTH SHALL HAVE EXPANSION JOINTS AT 25' INTERVALS (SEE DETAILS).

14. WEEP HOLES:

WEEP HOLES SHALL BE INSTALLED AT 10' O.C. IN THE FIRST ROW OF BLOCKS ABOVE FINISHED GROUND SURFACE. BACKFACE OF WALL WILL BE WATERPROOFED.

15. INTERCEPTOR SWALES:

INTERCEPTOR SWALE TO BE CONSTRUCTED AT BACK OF WALL WHEN DIRECTED BY THE CITY ENGINEER.



STANDARD DETAILS FOR PUBLIC WORKS CONSTRUCTION

DRAWING No.

**NOTES - MASONRY
RETAINING WALLS**

R-604D

APPROVED BY: JF | DATE: 12/2019

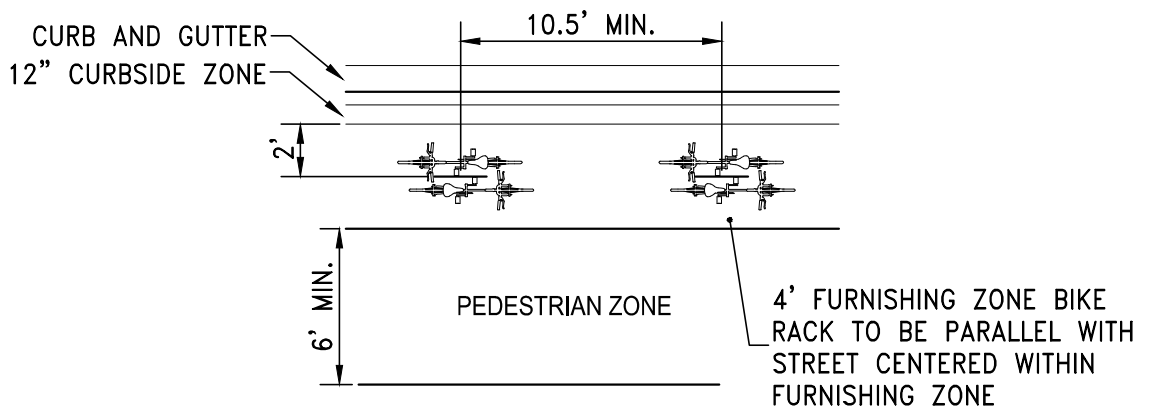

(2) 1/4" THICK STEEL PLATE. CUTOUT
ART/STREET NAME.

WELD CENTERED TO 2" PIPE,
POWDER COAT BLACK

1/4" THICK X 3" WIDE STEEL PLATE.
WELD CENTERED TO 2" PIPE,
POWDER COAT BLACK

BIKE RACK. INSTALL PLUMB IN
CONC. FOOTINGS. TOUCH UP
PAINT AS NECESSARY.

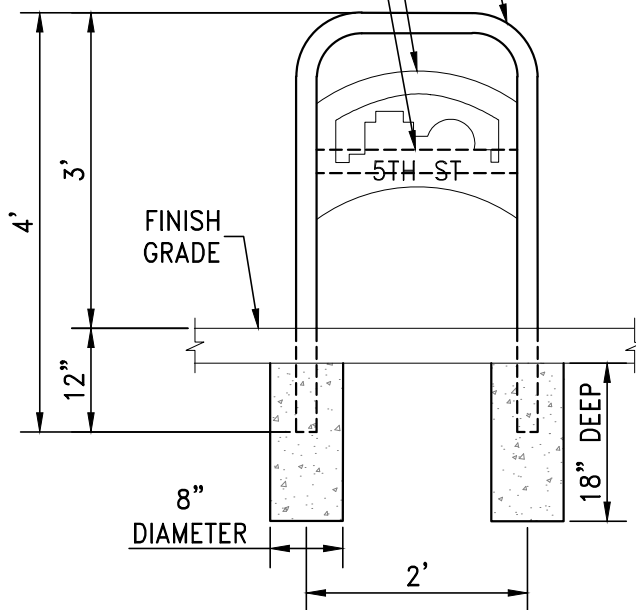

DIRECT BURY

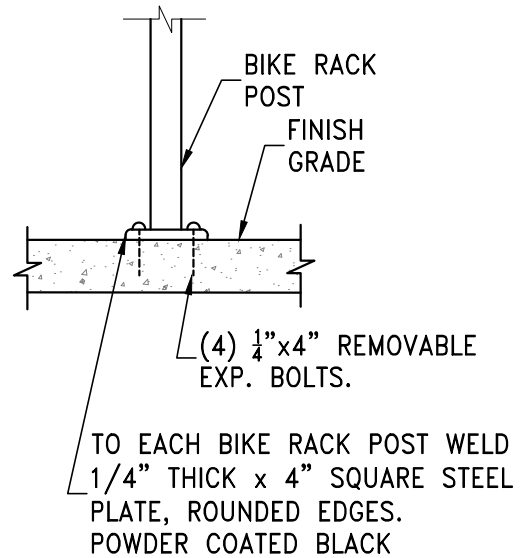

SURFACE MOUNT

NOTES:

- BIKE RACK TO BE 2" ROUND SCH 40 STEEL PIPE; BEND TO FORM & DIMENSIONS AS SHOWN. POWDER COAT BLACK.



STANDARD DETAILS FOR PUBLIC WORKS CONSTRUCTION

DRAWING No.

BIKE RACK

R-605

APPROVED BY: JF

DATE: 12/2019

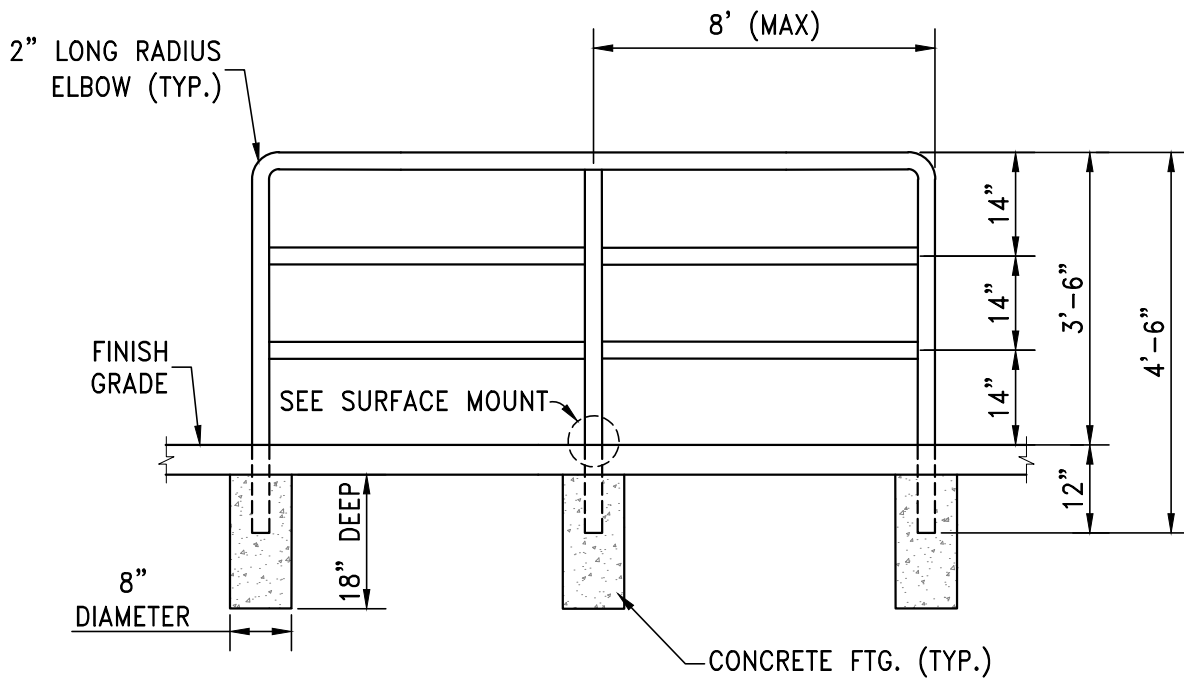

DIRECT BURY

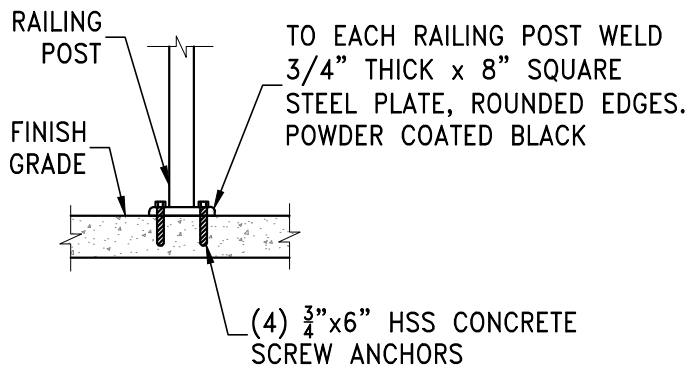

SURFACE MOUNT

NOTES:

1. RAILING TO BE 2" ROUND SCH 40 STEEL PIPE. POWDER COAT BLACK.
2. VERTICAL POSTS TO BE EQUALLY SPACED.
3. PORTLAND CEMENT CONCRETE (P.C.C.) SHALL BE 4000 PSI MIN. COMPRESSIVE STRENGTH AT 28 DAYS. ALL CEMENT CONCRETE SHALL HAVE A COARSE AGGREGATE GRADATION CONFORMING TO SIZE No. 67. POLYPROPYLENE OR CELLULOSE FIBERS SHALL BE ADDED TO P.C.C. AT 1.5 LBS PER CUBIC YARD. MIX DESIGN SHALL CONFORM TO THE REQUIREMENTS OF SSPWC. ALL MATERIALS SHALL CONFORM TO SSPWC.



STANDARD DETAILS FOR PUBLIC WORKS CONSTRUCTION

DRAWING No.

PEDESTRIAN SAFETY RAILING

R-606

APPROVED BY: KK

DATE: 2/2026